

Installation Guide

Philips MP5 Wall Mount



The purpose of this guide is to:

1. Describe mounting of Arm in channel (page 1).
2. Describe attachment of table top mount to Arm (page 2).
3. Describe mounting of monitor on Arm (page 2).
4. Describe swivel and tilt tension adjustment (page 3).

Parts Reference

The following parts and hardware are included with this installation kit (hardware not shown):

Item #	Description	Qty
1	Arm with Mounting Adapter	1
2	M6 x 12mm Flat Head Machine Screw (FHMS)	1
3	M6 x 8mm FHMS	2
*4	Spacer	1
*5	M6 x 14mm Pan Head Machine Screw (PHMS)	2
6	1/8" Hex Wrench	1
7	5/32" Hex Wrench	1

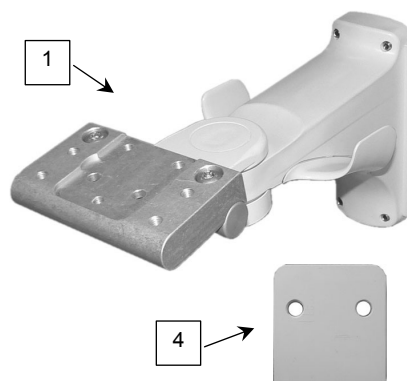

*See "Mounting MP5 with Non-Table Top Mounting Adapter" on page 2 for use of these parts.

Tools Required: Phillips screwdriver (not provided), 1/8" and 5/32" hex wrenches (provided), 1/2" [13mm] wrench (not provided).

Mounting Arm in Channel

1. Install Arm by guiding Slide (rear of Arm) into top of Channel. Slide Arm to desired position in channel and tighten four (4) set screws with the 1/8" hex wrench provided (shown below).

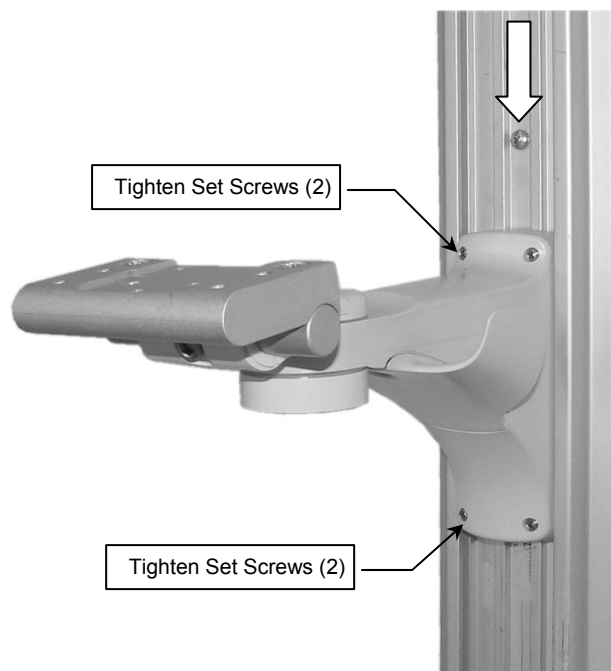

Mounting MP5 on the Arm

The MP5 monitor will be equipped with one of two different mounting interfaces on the bottom of the monitor. The type of interface determines which mounting procedure to follow below.

Mounting MP5 on Philips Table Top Mount (Requires Philips-supplied Table Top Mount)

1. Fasten Philips-supplied Table Top Mount to Mounting Adapter with one (1) M6 x 12mm FHMS and two (2) M6 x 8mm FHMS (see below).

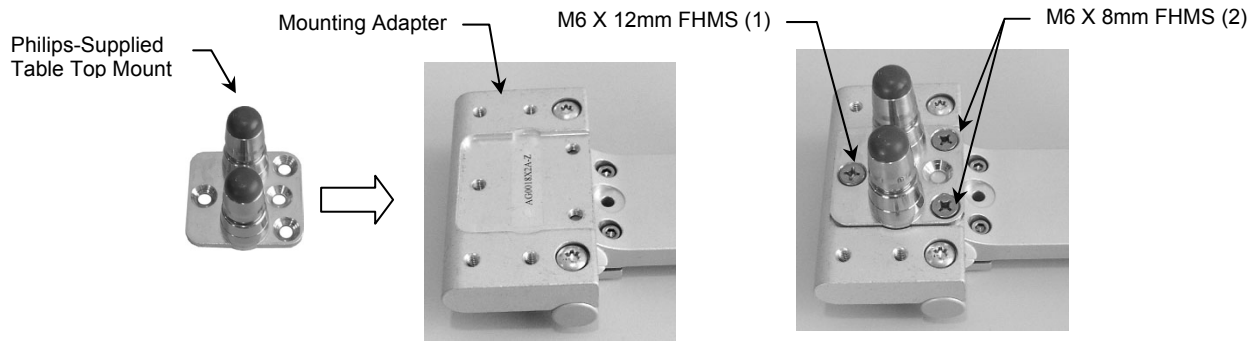

2. Mount the monitor in accordance with Philips mounting instructions.



Mounting MP5 with Non-Table Top Mounting Adapter

1. Fit Spacer into recessed area on top of Mounting Adapter (below left). Ensure Spacer remains between Mounting Adapter and monitor.
2. Using a Phillips screwdriver, fasten monitor to Mounting Adapter with two (2) M6 x 14 mm PHMS as shown.

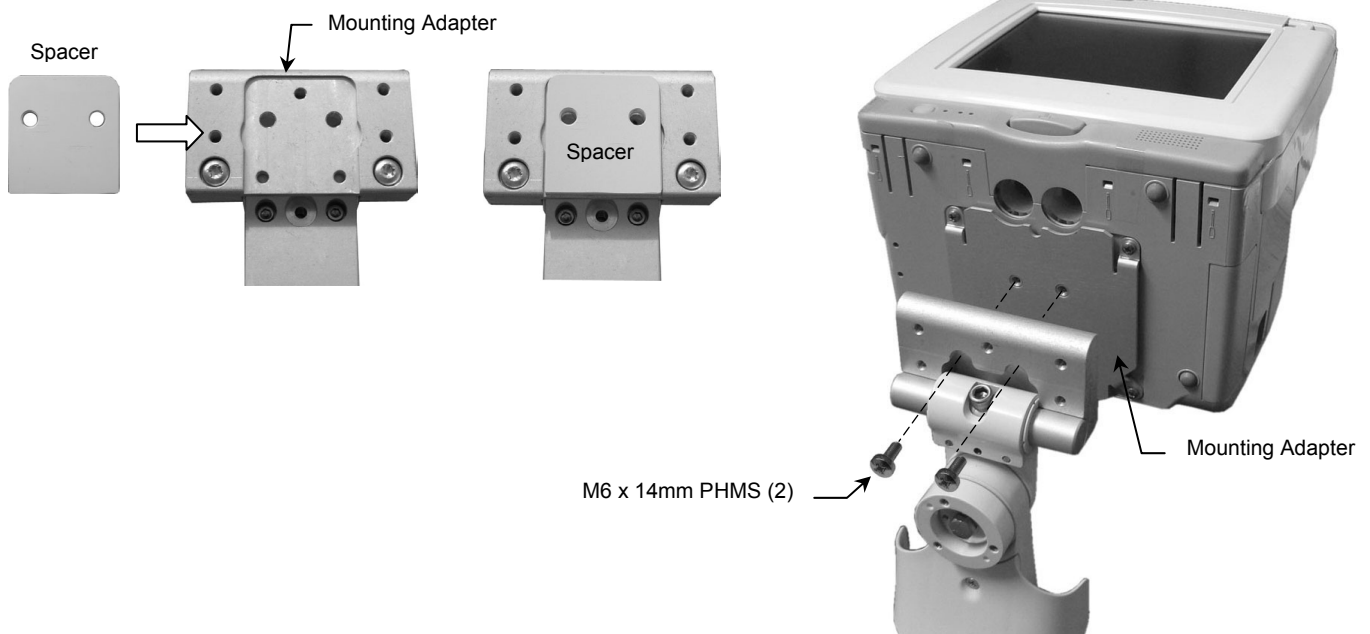

Adjusting Tilt Tension and Swivel Tension

Tilt Tension: Using the 5/32" hex wrench provided, equally tighten or loosen the two (2) Tilt Tension Screws.

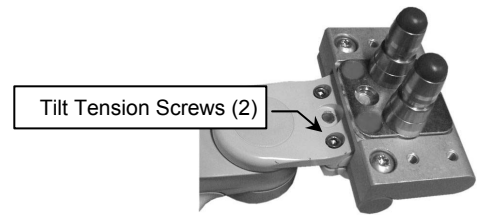

Swivel Tension: Using a 1/2" [13 mm] socket wrench, tighten or loosen Swivel Tension Nut (right) as necessary.

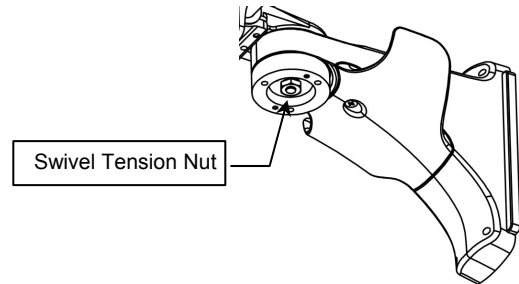

Routine Maintenance

Periodically check all mounting hardware. Tighten as necessary for optimal operation and safety.

Cleaning the Mounting Assembly

CAUTION: GCX makes no claims regarding the efficacy of the listed chemicals or processes as a means for controlling infection. Consult your hospital's infection control officer or epidemiologist. To clean or sterilize mounted instruments or accessory equipment, refer to the specific instructions delivered with those products.

1. The mounting assembly may be cleaned with most mild, non-abrasive solutions commonly used in the hospital environment (e.g. diluted bleach, ammonia, or alcohol solutions).
2. The surface finish will be permanently damaged by strong chemicals and solvents such as acetone and trichloroethylene.
3. Do not use steel wool or other abrasive material to clean the mounting assembly.
4. Damage caused by the use of unapproved substances or processes will not be covered by warranty. We recommend testing of any cleaning solution on a small area of the mounting assembly that is not visible to verify compatibility.
5. Never submerge or allow liquids to enter the mounting assembly. Wipe any cleaning agents off the mounting assembly immediately using a water-dampened cloth. Dry all mounting assemblies thoroughly after cleaning.