



Philips Corepro LEDtube T8



PHILIPS



Corepro LEDtube T8 is a reliable value-for-money LED lamp out of Philips lighting portfolio, incorporated with frontier LED chips and other advanced technologies. The product helps customers to achieve over 55% energy saving and significant maintenance cost reduction by comparing to fluorescent lamps. It also helps generate natural and comfortable lighting effect, and to build up green and environment friendly image for our customers.

Product Features

Maintain high performance

- Reliable operation between -20 °C to 45 °C ambient temperature
- Trustable claimed lifetime
- 50,000 switching cycles

Easy to experience

- CRI 80
- Instant on, no flicker or buzz
- Advanced optical design ensures a uniform light output and superior optical efficiency

Energy Efficient

- Energy savings over 55%*

* Based on comparison between 18W Corepro LEDtube standard and Philips TLD standard or super 80 36W (40-44W system power when working with Electro Magnetic Ballasts)

Safe and forget

- Protection circuit inside ensuring people's safety in case of mis-use, complying with IEC safety requirements
- Pass 4KV high-pot test, insulation & safety guaranteed
- Pass 1KV surge test (vs. IEC standard 500V), avoiding the damage caused by input voltage fluctuation and lightning strike
- 100% comply with IEC requirement on T8 dimension, fitting into fluorescent luminaire perfectly

Environmental Friendly

- No mercury and glass
- No breakage and pollution risk

Compatibility

- Compatible with electromagnetic ballasts by replace the fluorescent starter with Philips starter, eliminating the need for rewiring and allows fixture to maintain original CE compliance

Application

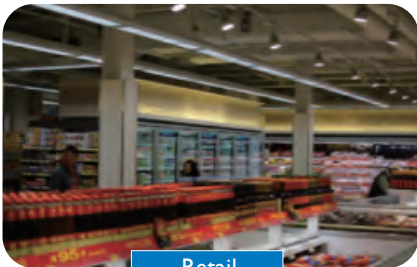

Retail



Industry

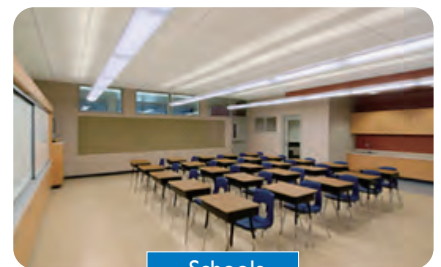

Schools

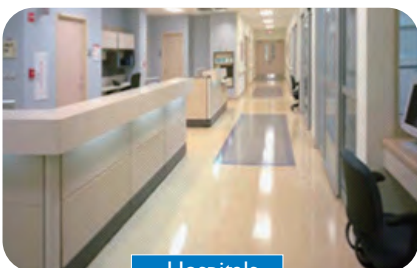

Hospitals

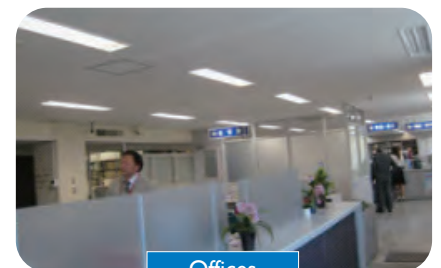

Offices

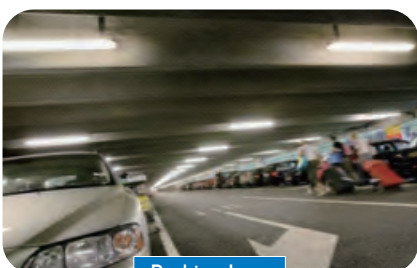

Parking Lots

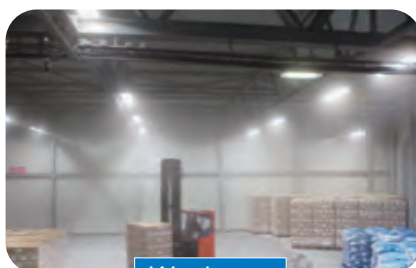

Warehouses

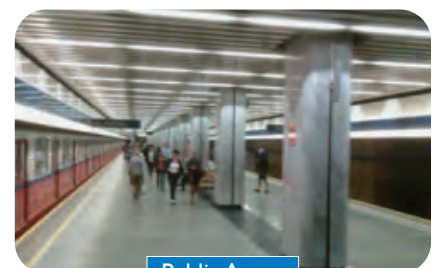

Public Areas

Spectral Power Distribution

Light may be precisely characterized by giving the power of the light at each wavelength in the visible spectrum. The resulting spectral power distribution (SPD) shows that the Corepro LEDtube contains the visible light only. No harm from UV and IR.

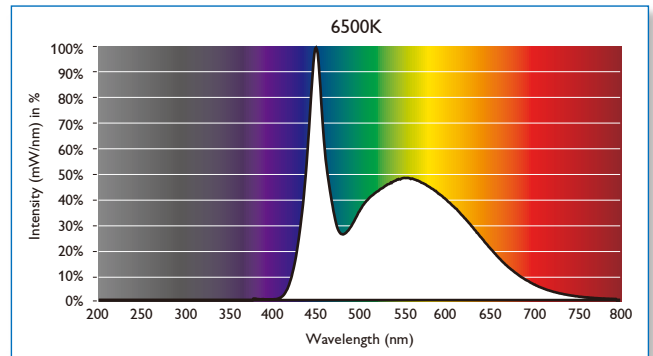
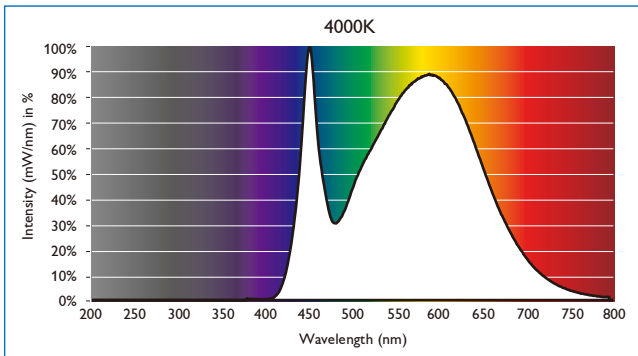

Photometric Diagrams

The Photometric diagram depicting the top down mounted lighting fixtures in a specific area and a numerical grid of the maintained lighting levels that the fixture will produce in that specific area. Pictures below show the photometric diagrams of a typical Philips Corepro LEDtube's application.

1 x TLED 9W 4000K/6500K

1 x 800 lm

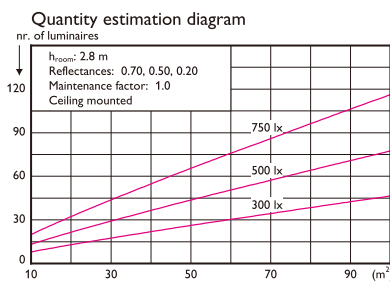
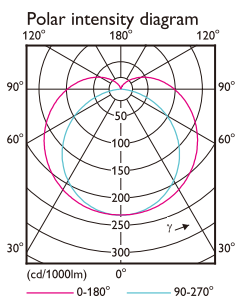

Utilisation factor table

Room Index k	Reflectances (%) for ceiling, walls and working plane (CIE)											
	0.80	0.80	0.70	0.70	0.70	0.70	0.50	0.50	0.30	0.30	0.30	0.00
0.80	0.50	0.50	0.50	0.50	0.50	0.30	0.30	0.10	0.10	0.10	0.10	0.00
1.00	0.60	0.60	0.57	0.56	0.54	0.46	0.44	0.38	0.41	0.37	0.33	0.00
1.25	0.68	0.62	0.65	0.62	0.60	0.53	0.50	0.45	0.47	0.43	0.38	0.00
1.50	0.74	0.67	0.71	0.68	0.65	0.58	0.55	0.50	0.52	0.47	0.43	0.00
2.00	0.84	0.75	0.80	0.76	0.72	0.66	0.62	0.58	0.59	0.55	0.50	0.00
2.50	0.90	0.80	0.86	0.81	0.77	0.71	0.68	0.63	0.64	0.60	0.55	0.00
3.00	0.95	0.83	0.91	0.85	0.81	0.76	0.72	0.68	0.68	0.64	0.59	0.00
4.00	1.02	0.88	0.97	0.91	0.85	0.81	0.77	0.73	0.73	0.70	0.64	0.00
5.00	1.06	0.91	1.01	0.94	0.88	0.84	0.80	0.77	0.76	0.73	0.67	0.00

Luminance Table

Plane Cone	0.0	15.0	30.0	45.0	60.0	75.0	90.0
45.0	6398	6338	6411	6623	7055	7990	9724
50.0	6122	6045	6091	6264	6637	7560	9422
55.0	5864	5770	5787	5913	6209	7087	9048
60.0	5634	5519	5503	5577	5774	6570	8580
65.0	5420	5290	5244	5264	5334	5992	7964
70.0	5225	5081	5004	4968	4988	5362	7158
75.0	5055	4890	4783	4701	4665	4655	4633
80.0	4902	4723	4590	4458	4365	3927	4499
85.0	4769	4580	4426	4253	3714	3221	3271
90.0	4667	4463	4297	4102	3473	2866	2883

1 x TLED 18W 4000K/6500K

1 x 1600 lm

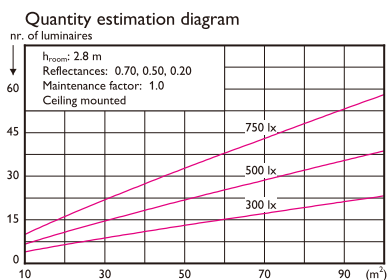
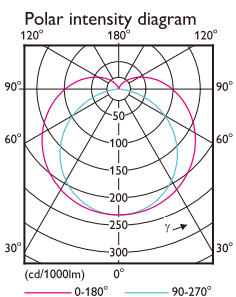

Utilisation factor table

Room Index k	Reflectances (%) for ceiling, walls and working plane (CIE)											
	0.80	0.80	0.70	0.70	0.70	0.70	0.50	0.50	0.30	0.30	0.30	0.00
0.80	0.50	0.50	0.50	0.50	0.50	0.30	0.30	0.10	0.10	0.10	0.10	0.00
1.00	0.60	0.60	0.57	0.56	0.54	0.46	0.44	0.38	0.41	0.37	0.33	0.00
1.25	0.68	0.62	0.65	0.62	0.60	0.53	0.50	0.45	0.47	0.43	0.38	0.00
1.50	0.74	0.67	0.71	0.68	0.65	0.58	0.55	0.50	0.52	0.47	0.43	0.00
2.00	0.84	0.75	0.80	0.76	0.72	0.66	0.62	0.58	0.59	0.55	0.50	0.00
2.50	0.90	0.80	0.86	0.81	0.77	0.71	0.68	0.63	0.64	0.60	0.55	0.00
3.00	0.95	0.83	0.91	0.85	0.81	0.76	0.72	0.68	0.68	0.64	0.59	0.00
4.00	1.02	0.88	0.97	0.91	0.85	0.81	0.77	0.73	0.73	0.70	0.64	0.00
5.00	1.06	0.91	1.01	0.94	0.88	0.84	0.80	0.77	0.76	0.73	0.67	0.00

Luminance Table

Plane Cone	0.0	15.0	30.0	45.0	60.0	75.0	90.0
45.0	6400	6359	6452	6685	7149	8131	9942
50.0	6121	6064	6131	6328	6734	7710	9674
55.0	5864	5790	5808	5979	6311	7250	9336
60.0	5632	5542	5549	5650	5879	6739	8911
65.0	5419	5311	5289	5339	5442	6170	8344
70.0	5224	5102	5050	5046	5011	5547	7581
75.0	5052	4912	4831	4779	4579	4847	6519
80.0	4900	4747	4640	4539	4179	4115	5016
85.0	4770	4604	4479	4342	3842	3424	2758
90.0	4669	4492	4353	4192	3666	3092	4276

Lifetime and Lumen Maintenance

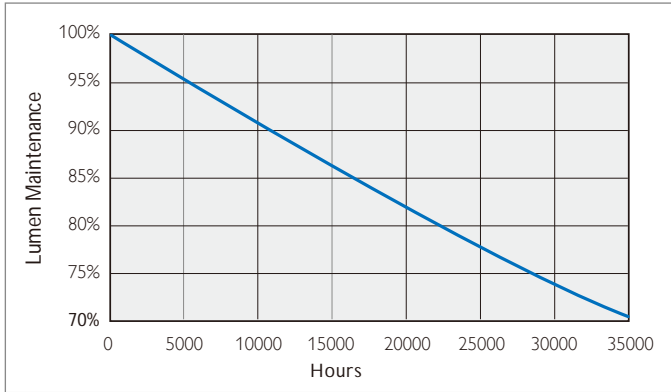

PHILIPS Corepro LEDtube has a lifetime of 30,000 hours, defined as the number of hours when 50% of a large group of identical lamps below 70% of its initial lumens.

Temperature

Corepro LEDtube's excellent thermal design ensures low temperature during operating, which brings reliable and stable product performance throughout life time.

Operating temperature	T _{operating}	min -20°C	max +45°C
Storage temperature	T _{storage}	min -40°C	max +65°C
Maximum surface temperature of tube at Tamb.=25°C	T _{surface}		+53°C

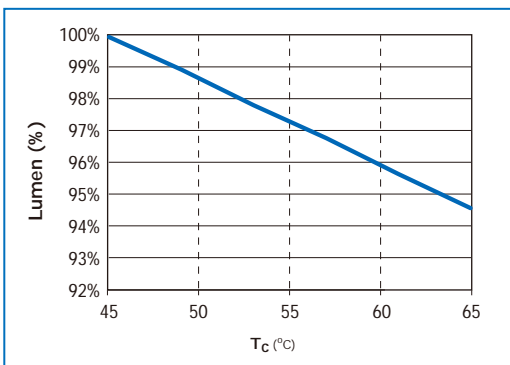

Dimension: mm

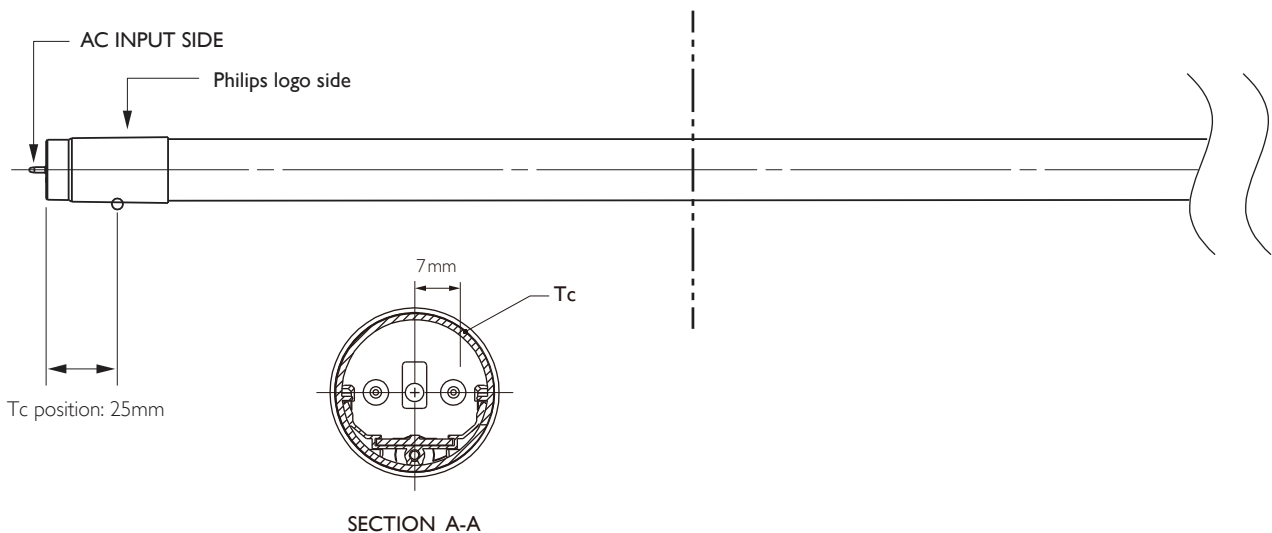
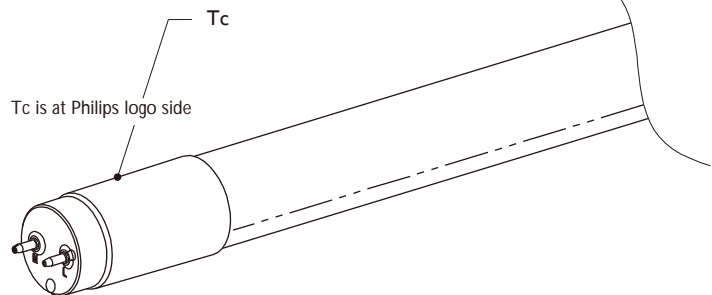

Approbation & Certificates

Philips LEDtube is designed by strictly following applicable legislation and international standard. The product complies with **CE, KEMA, RoHS and REACH.**

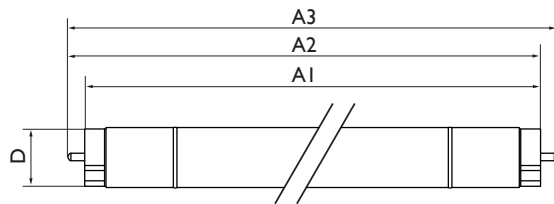

Dimensions (mm)

Product	A1	A2	A3	D
600mm	588.5	595.5	602.5	27.5
1200mm	1198	1205	1212	27.5

Technical specification

Product Description	Wattage	Voltage	Cap	Length	Beam Angle	Lifetime	Lumen output	CCT	CRI *	Pcs per BOX	Lamp Weight	Model Number
	(W)	(V)		(mm)		(hrs)	(lm)	(K)	(Typical)		(g)	
Corepro LEDtube 1200mm 18W840 T8	18	220-240	G13	1200	150	30,000	1600	4000	80	10	280	9290002966
Corepro LEDtube 1200mm 18W865 T8	18	220-240	G13	1200	150	30,000	1600	6500	80	10	280	9290002967
Corepro LEDtube 600mm 9W840 T8	9	220-240	G13	600	150	30,000	800	4000	80	10	160	9290002968
Corepro LEDtube 600mm 9W865 T8	9	220-240	G13	600	150	30,000	800	6500	80	10	160	9290002969

* minimum is 77

Quick Installation Guide

Please take the time to read this quick installation guide. Philips Lighting does not accept liability for any damages for installations not performed according to this guide or not performed by a professional electrician.

Installation Warning

- Check whether the system is an EM (Electro Magnetic) ballast based system or an HF (High Frequency electronic) ballast based system, and follow the appropriate instructions accordingly. For new built luminaires follow section "New built luminaires".
- Product is not dimmable
- Always switch off the power supply before commencing work
- Do not change the structure or any components of the product

Application Notes

- Operation temperature range is between -20°C and +45°C ambience.
- Only to apply in dry indoor usage and environments.
- Not intended for use with emergency light fixtures or exit light.
- For use in fixtures which consist of IEC compliant G13 bi-pin lamp holders which can support 500 gram.

Installation Guide

- EM ballast based system

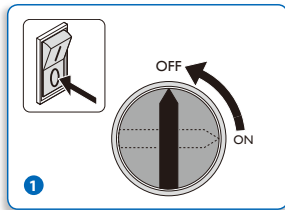

Mains Off

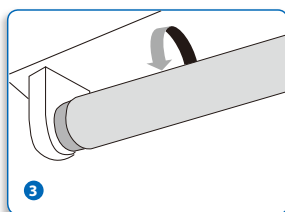
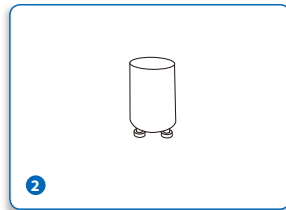

Remove all existing FLUORESCENT TUBES from luminaire

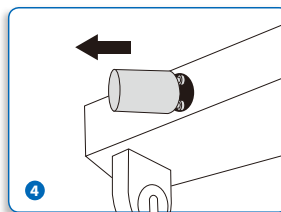
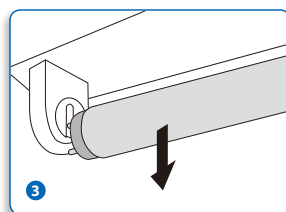

Remove all existing STARTERS from luminaire

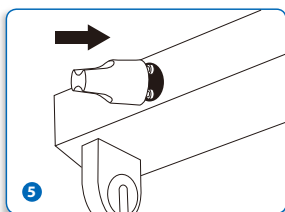

Install EMP starter replacement only

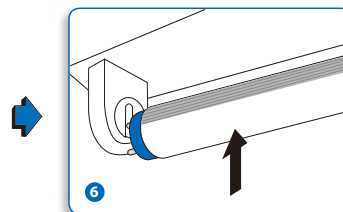

Install the LEDtube

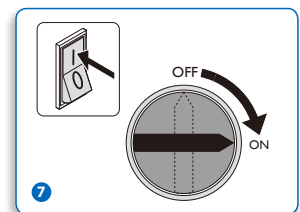
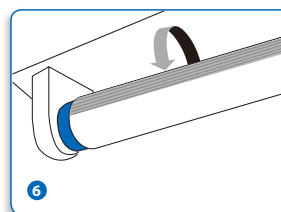

Turn on mains

For EM ballast installations please check if a Power Factor Correcting Capacitor is installed in the existing circuit. If yes, please follow the instructions below:

- Please simply remove the capacitor if it is in parallel with the EM Ballast
- Please short circuit the capacitor if it is in series with the EM Ballast
- In case of 2ft/600mm lamps, if there is only one starter in the luminaire for 2 lamps, or 2 starters for 4 lamps, then rewire according to the SAFE rewiring instructions in next section

• HF ballast based system

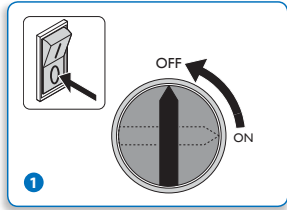

Mains Off

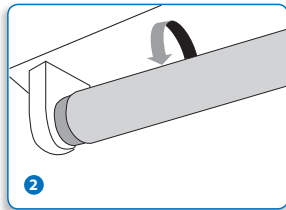

Remove all existing FLUORESCENT TUBES from luminaire

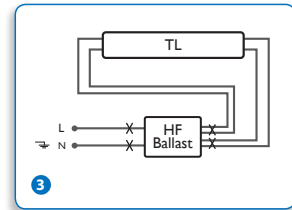
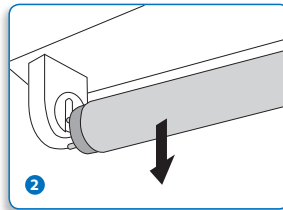

By pass HF

For 3 lamps use diagram A & B

For 4 lamps use diagram B & B

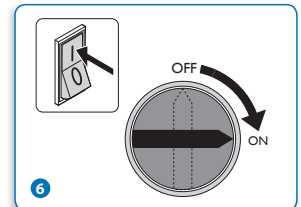
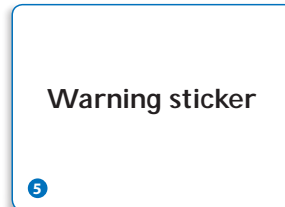
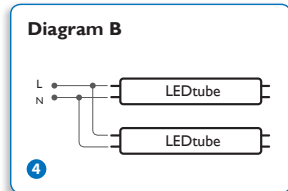
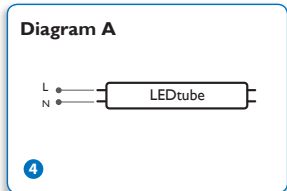

Turn on mains

Bypass existing HF BALLAST and rewire according to the following diagrams.

Please check the L/N markings on the lamp end and insert the lamp with AC mains supplied to the corresponding end.

To install the lamp in the wrong direction will lead to malfunction.



The supplied warning sticker must be placed on the luminaire and must be visible during lamp replacement

• New built luminaires

Number of tube	Wire according to diagram
1	C
2	D
3	C+D
4	D+D

Please check the L/N markings on the lamp end and insert the lamp with AC mains supplied to the corresponding end.

To install the lamp in the wrong direction will lead to malfunction.

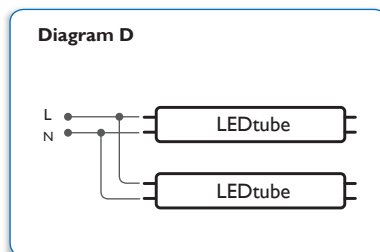
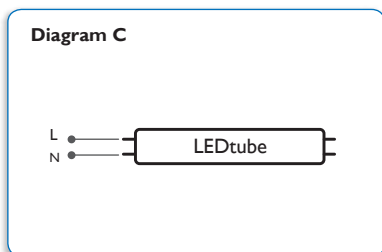
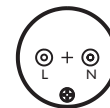

OEM Guideline

Failure rate vs. Lifetime @ Ta 25 °C

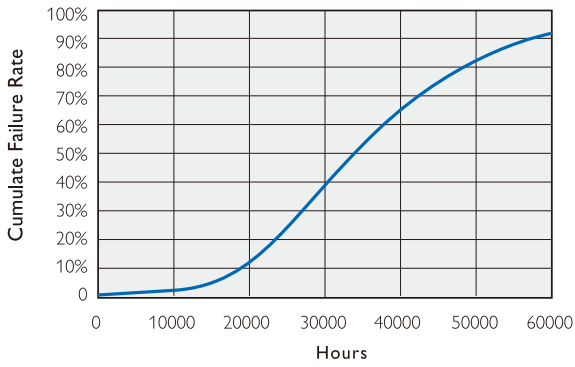

Lumen Maintenance vs. Lifetime

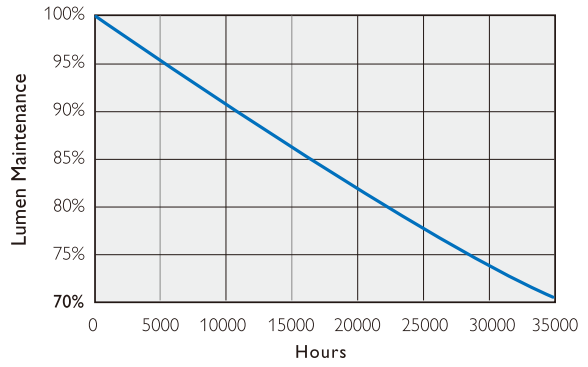

Failure Rate vs. Lifetime vs. Tcase

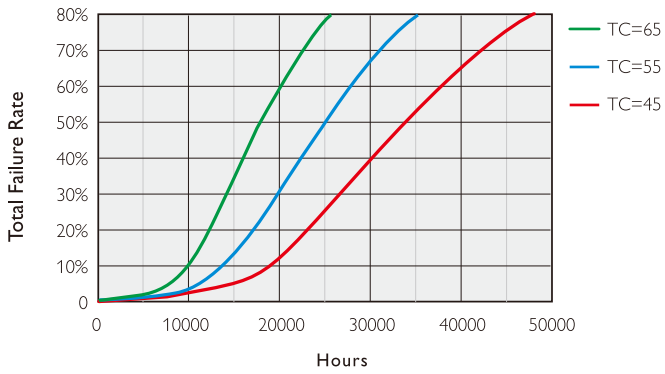

Lifetime vs. Tcase

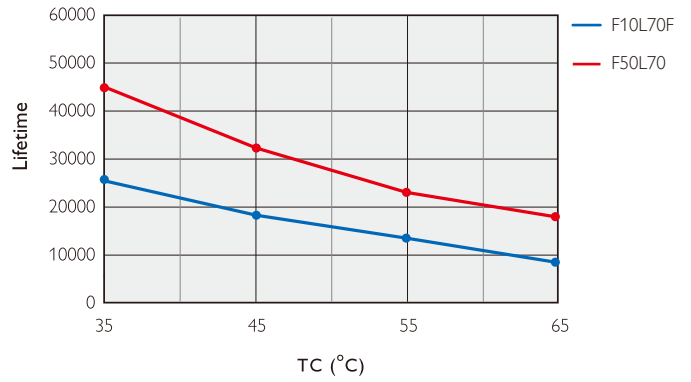

© 2015 Philips Lighting

All rights reserved. Reproduction in whole or in part is prohibited without the prior written consent of the copyright owner. The information presented in this document does not form part of any quotation or contract, is believed to be accurate and reliable and may be changed without notice. No liability will be accepted by the publisher for any consequence of its use. Publication thereof does not convey nor imply any license under patent or other industrial or intellectual property rights.

04/2015
www.philips.com