

PHILIPS

Fortimo

LED system

LED Square 2500 lm
HV/LV1

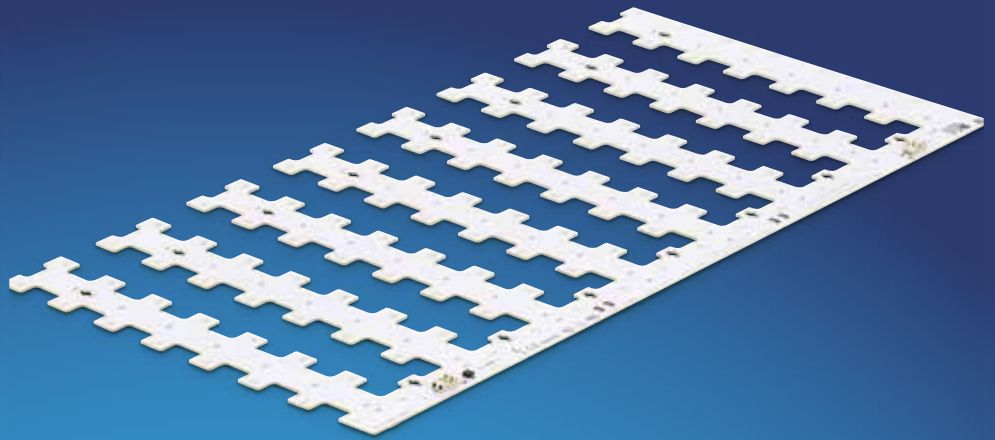

Datasheet

Fortimo LED Square

Fortimo LED Square systems consist of white light LED modules with square outer dimensions delivering high energy efficiency and high quality of light. Fortimo LED Square systems are ideal for office applications where the luminaires require a very homogeneous exit surface window. Typical applications are recessed, surface mounted and suspended office luminaires.

Key features and benefits

- LED module efficiency up to 175 lm/w
- Long life-time: >50,000 hours
- High color rendering (CRI >80)
- Excellent color consistency of 3 SDCM
- Choice of color temperatures (3000 K, 4000 K and 6500 K)
- Tunable lumen output, efficacy and lifetime
- Wide temperature (Tc) range from -40 °C to +80 °C
- Push-in connectors enabling automated wiring
- Five year system warranty

Suitable for:

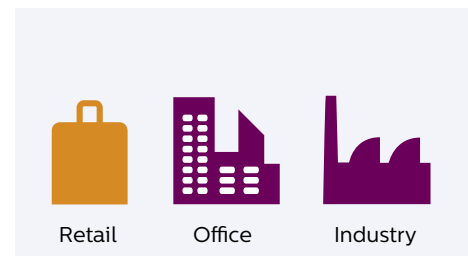

Ordering data

Commercial product name	EOC	12NC
Fortimo LED Square 2500lm 830 HV/LV1	8718696 471555 00	9290 009 58406
Fortimo LED Square 2500lm 840 HV/LV1	8718696 471579 00	9290 009 58506
Fortimo LED Square 2500lm 865 HV/LV1	8718696 471593 00	9290 009 58606

Drive currents and case temperatures

Parameter	Nominal*	Life**	Max***	Unit
I (current through the LED module)	332	700	700	mA
Tc (case temperature at Tc point)	45	75	80	°C

* Nominal value at which typical performance is specified.

** Value at which lifetime L70B50 ≥ 50,000 hour is specified.

*** Maximum value for safe operation; do not operate above this value.

Optical characteristics - table per color (CCT)

Fortimo LED Square 2500 lm 830 HV/LV1

Parameter	Min	Typ	Max	Unit
Correlated color temperature (CCT)		3000		K
Color coordinates (CIEx, CIEy)*		(0.433, 0.400)		-
CRI**	80			-
Radiation angle		120		deg

Color consistency of 3 SDCM, averaged over the module.

Operation point	830	lm	lm/W
80% I-nom 266 mA	Tc 25 °C	1932	164
	Tc-nom 45 °C	1857	160
	Tc-life 75 °C	1738	152
I-nom 332 mA	Tc 25 °C	2414	162
	Tc-nom 45 °C	2322	158
	Tc-life 75 °C	2175	151
I-life 700 mA	Tc 25 °C	4890	148
	Tc-nom 45 °C	4710	144
	Tc-life 75 °C	4422	137

Tolerance for flux data is ±7.5%.

Tolerance for efficacy data is ±10%.

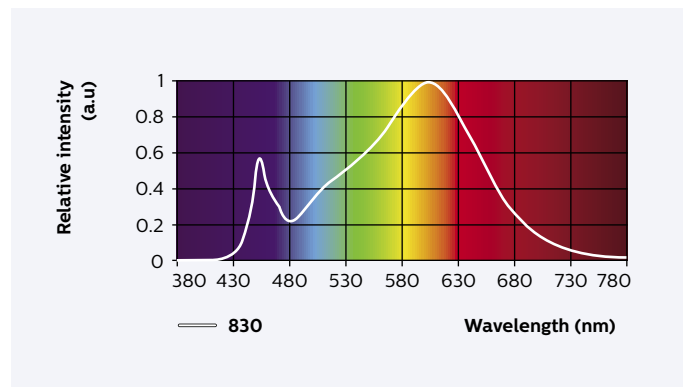

Fortimo LED Square 2500 lm 840 HV/LV1

Parameter	Min	Typ	Max	Unit
Correlated color temperature (CCT)		4000		K
Color coordinates (CIEx, CIEy)*		(0.381, 0.376)		-
CRI**	80			-
Radiation angle		120		deg

Color consistency of 3 SDCM, averaged over the module.

Operation point	840	lm	lm/W
80% I-nom 266 mA	Tc 25 °C	2080	177
	Tc-nom 45 °C	1999	172
	Tc-life 75 °C	1872	164
I-nom 332 mA	Tc 25 °C	2599	175
	Tc-nom 45 °C	2500	170
	Tc-life 75 °C	2342	162
I-life 700 mA	Tc 25 °C	5265	159
	Tc-nom 45 °C	5071	155
	Tc-life 75 °C	4762	148

Tolerance for flux data is ±7.5%.

Tolerance for efficacy data is ±10%.

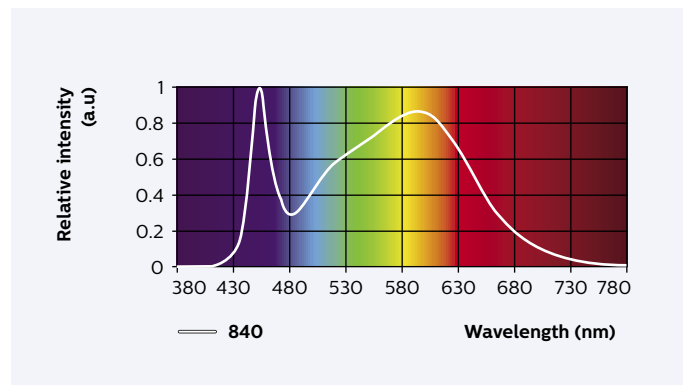

Fortimo LED Square 2500 lm 865 HV/LV1

Parameter	Min	Typ	Max	Unit
Correlated color temperature (CCT)		6500		K
Color coordinates (CIEx, CIEy)*		(0.312, 0.325)		-
CRI**	80			-
Radiation angle		120		deg

Color consistency of 3 SDCM, averaged over the module.

Operation point	865	lm	lm/W
80% I-nom 266 mA	Tc 25 °C	2080	177
	Tc-nom 45 °C	1999	172
	Tc-life 75 °C	1872	164
I-nom 332 mA	Tc 25 °C	2599	175
	Tc-nom 45 °C	2500	170
	Tc-life 75 °C	2342	162
I-life 700 mA	Tc 25 °C	5265	159
	Tc-nom 45 °C	5071	155
	Tc-life 75 °C	4762	148

Tolerance for flux data is $\pm 7.5\%$.
Tolerance for efficacy data is $\pm 10\%$.

Measurement tolerance is $\pm 2.5\%$ for the flux data and 5% for the efficacy data.

* Measurement tolerance is ± 0.004

** Measurement tolerance is ± 1

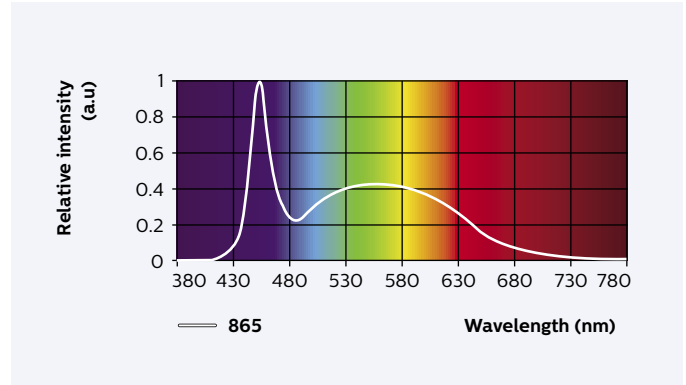

Beam shape

The Philips LED module generates a Lambertian beam shape, which is a pragmatic starting point for OEMs wishing to design secondary optics.

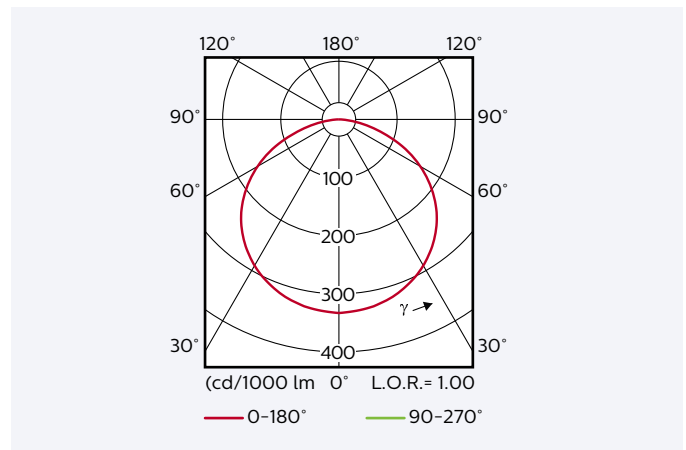

Electrical characteristics

Parameter	Min	Typ	Max	Unit
Nominal current		332		mA
Forward voltage	43.0	44.3	45.6	V
Power consumption	14.3	14.7	15.1	W
Energy efficiency label		A++		
Minimum dimming for performance	10			%
Number of modules per chain			4	
Bins		2 (C and D)		

Specifications stated at Tc-nom and I-nom.

Performance over life

Lumen maintenance

Operation point	Time x 1000 hours	L70			L80			L90		
		B50	B20	B10	B50	B20	B10	B50	B20	B10
80% I-nom 266 mA	Tc 25 °C	>50	>50	>50	>50	>50	>50	30	29	29
	Tc-nom 45 °C	>50	>50	>50	50	49	48	23	23	23
	Tc-life 75 °C	>50	>50	>50	36	36	35	17	17	17
I-nom 332 mA	Tc 25 °C	>50	>50	>50	>50	>50	>50	30	29	29
	Tc-nom 45 °C	>50	>50	>50	50	49	48	23	23	23
	Tc-life 75 °C	>50	>50	>50	36	36	35	17	17	17
I-life 700 mA	Tc 25 °C	>50	>50	>50	>50	>50	>50	30	29	29
	Tc-nom 45 °C	>50	>50	>50	50	49	48	23	23	23
	Tc-life 75 °C	>50	>50	>50	36	36	35	17	17	17

Values in the table are based on available LM80 LED data (9000h). Lumen maintenance will be updated once additional measurement data becomes available.

Parameter	Min	Typ	Max	Unit
$\Delta u'v'$ at 6000 hours			0.007	-

Specifications stated while $T_c < T_c\text{-life}$ and $I < I\text{-life}$.

Absolute maximum ratings

Parameter	Min	Typ	Max	Unit
Current through the LED module (I-max)			700	mA
Case temperature (Tc-max)			80	°C
Power rated at U-max and I-max			36.4	W
ESD (direct contact)			8	kV
ESD (air)			15	kV
Working voltage (between input to metal mounting plate)			460	Vdc
Voltage strength (Input to metal mounting plate)			1920	Vac
Ambient temperature	-40			°C

Wiring

Specification item	Value	Unit	Condition
Input wire cross-section	0.2...0.75	mm ²	Solid
	18...24	AWG	
	0.3...0.5	mm ²	Stranded
	20...22	AWG	
Input wire strip length	7.5..8.5	mm	
Tested cable length for EMC	4000	mm	Total length of wiring including LED modules, one way. For longer lengths we advise to repeat EMC test.

Connector suited for robot wiring.

Mechanical characteristics

Parameter	Min	Typ	Max	Unit
Length	520	520.5	521	mm
Width	259.5	260	260.5	mm
Height excl. connector	2	2.1	2.2	mm
Height incl. connector	5.6	5.8	6	mm
Warpage (IPC-TM-650)			4	%

Bow & Twist of the PCB after production tested and released according IPC-TM-650 2.4.22.

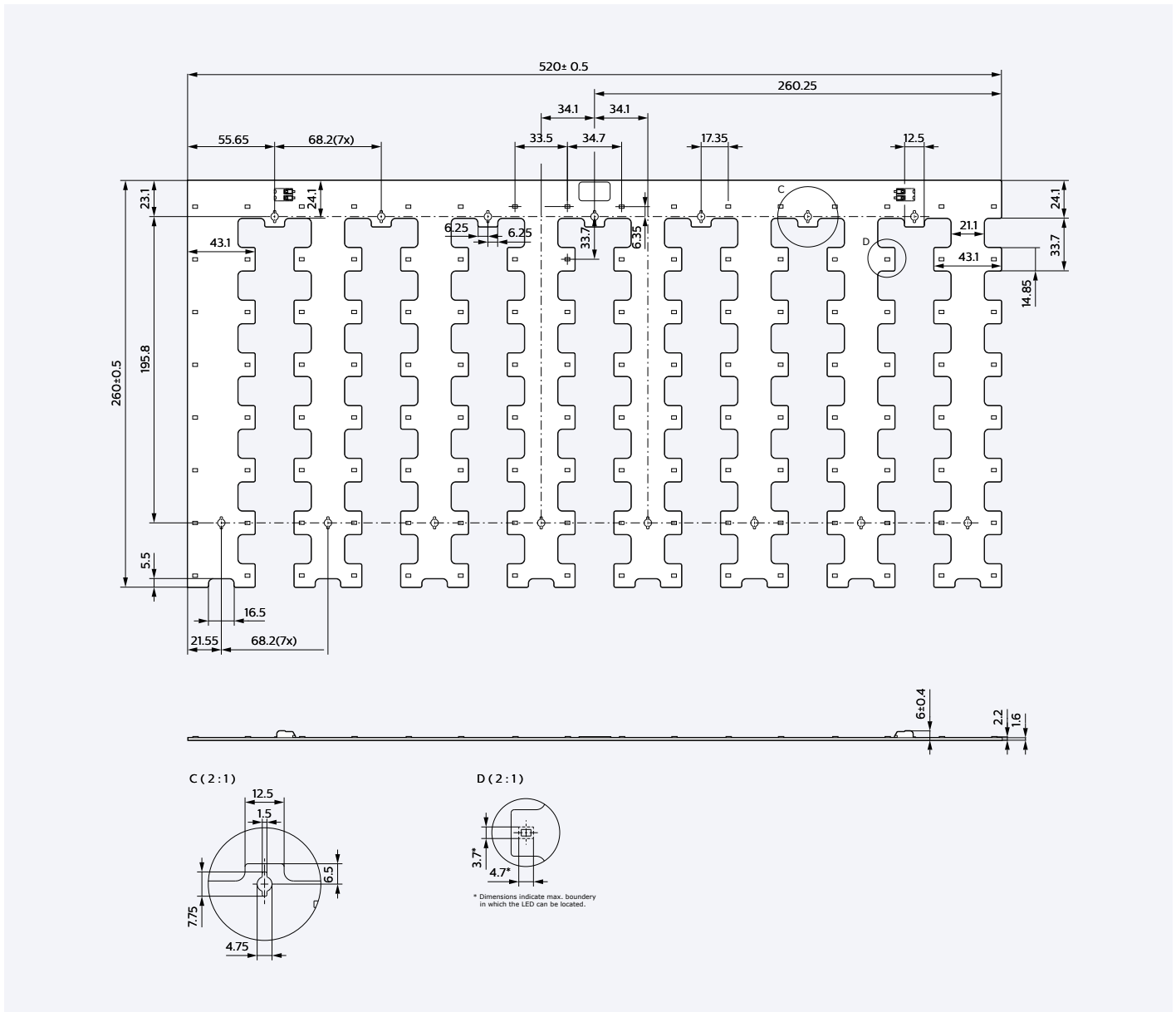

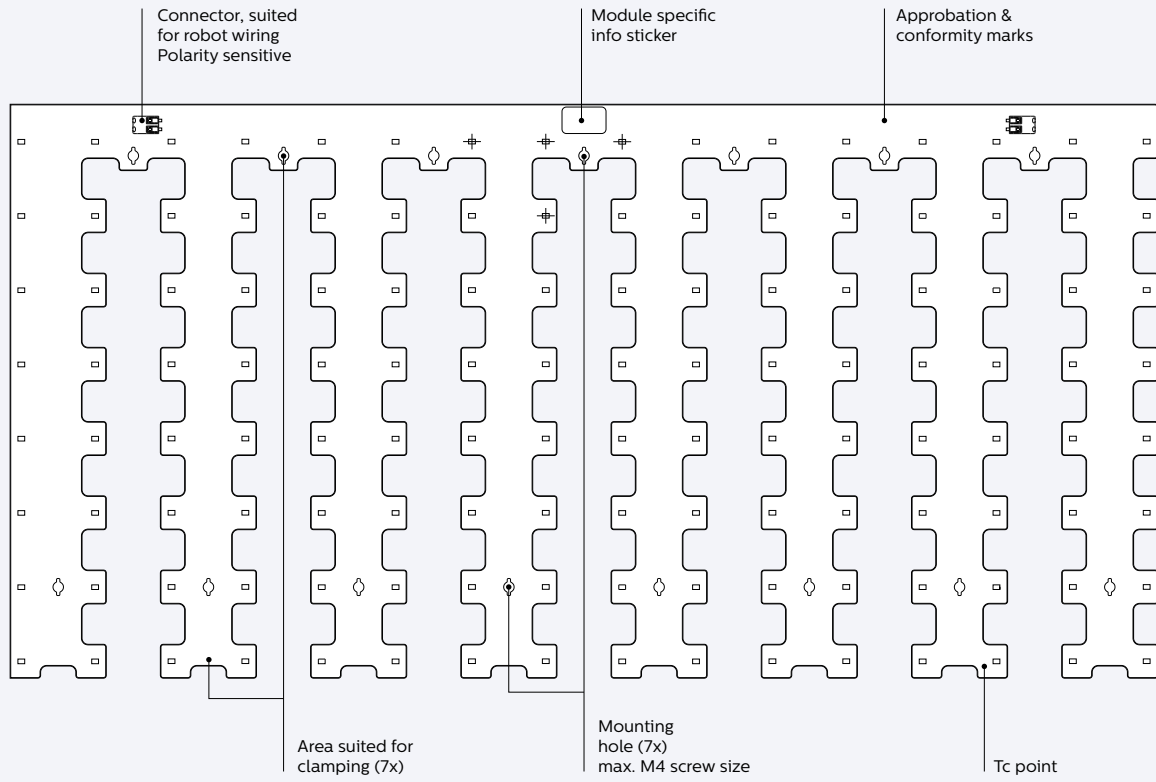

Application information

Compliance and approval

IEC / EN 62031, IEC / EN 62471

Photobiological safety

Risk group: exempt

Environmental

RoHS / REACH

Application information

IP rating	No IP rating
Overheating protection	No protection
Luminaire class	IEC Class I or Class II

Warranted number of full thermal product cycles at which the survival rate of the population $\geq 90\%$, at 25°C ambient temperature

Case temperature T _c [°C]	Amount of cycles
35	14,600
40	
45	14,600
50	
55	14,600
60	
65	14,600
70	
75	14,600
80	
85	
90	
95	

Tuning information

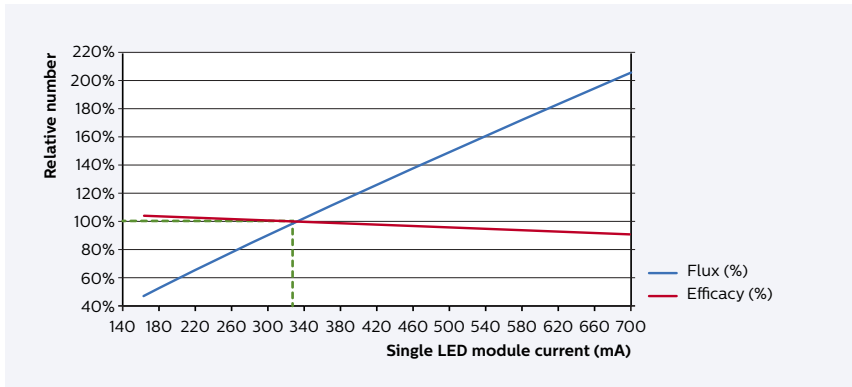

Flux and efficacy versus current

	I [mA]	Flux [%]	Efficacy [%]
(I-nom x 50%)	165	49%	101%
	200	60%	102%
(I-nom)	332	100%	100%
	400	120%	98%
	600	176%	93%
(I-life)	700	203%	91%

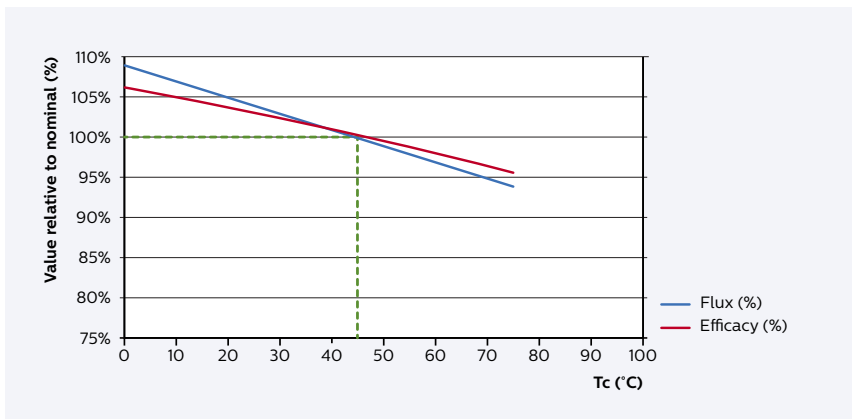

Flux and efficacy versus temperature at Tc

	Tc [°C]	Flux [%]	Efficacy [%]
(Tc-life)	75	94%	95%
(Tc-nom)	45	100%	100%
	25	104%	103%
	0	109%	106%

Lumen maintenance

Lumen maintenance at I-life and Tc-life conditions

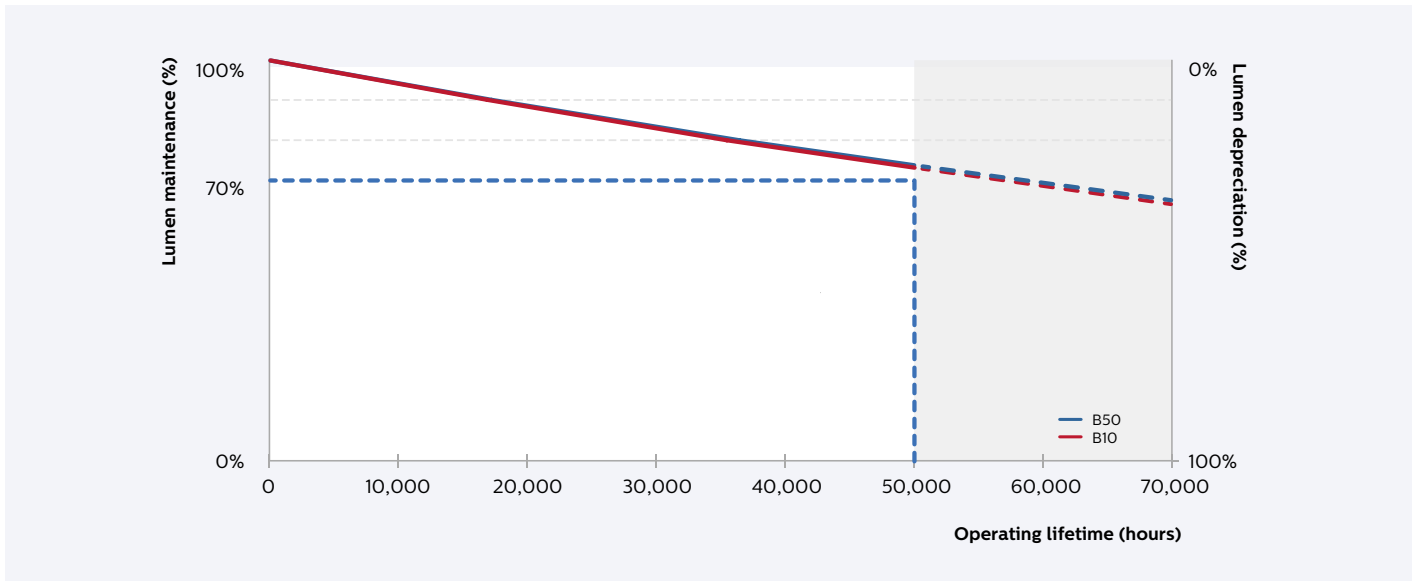

Lumen depreciation as a function of operating hours for I-life and Tc-life.

Lumen maintenance for B50 at current I-life conditions

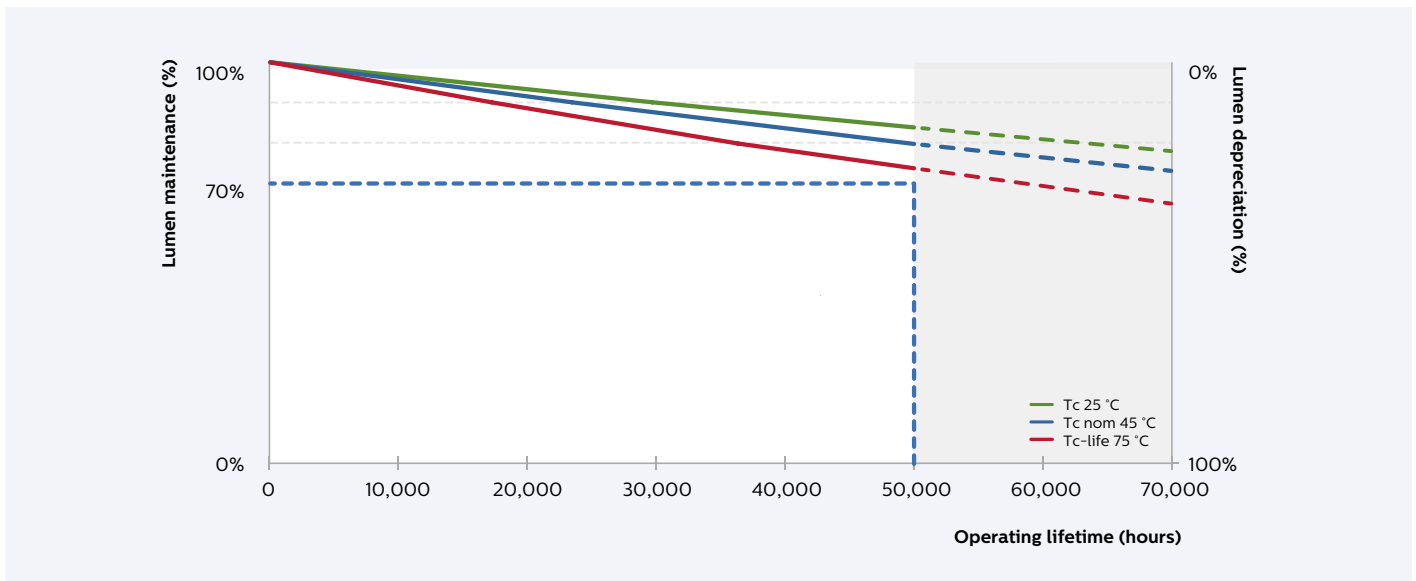

Lumen depreciation as a function of operating hours at different Tc values and I-life.

Wiring schematic

Examples

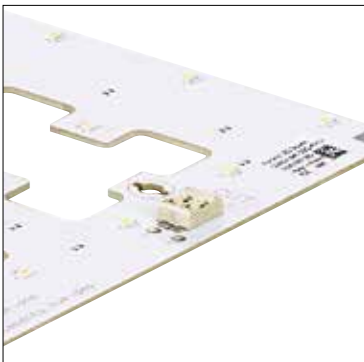
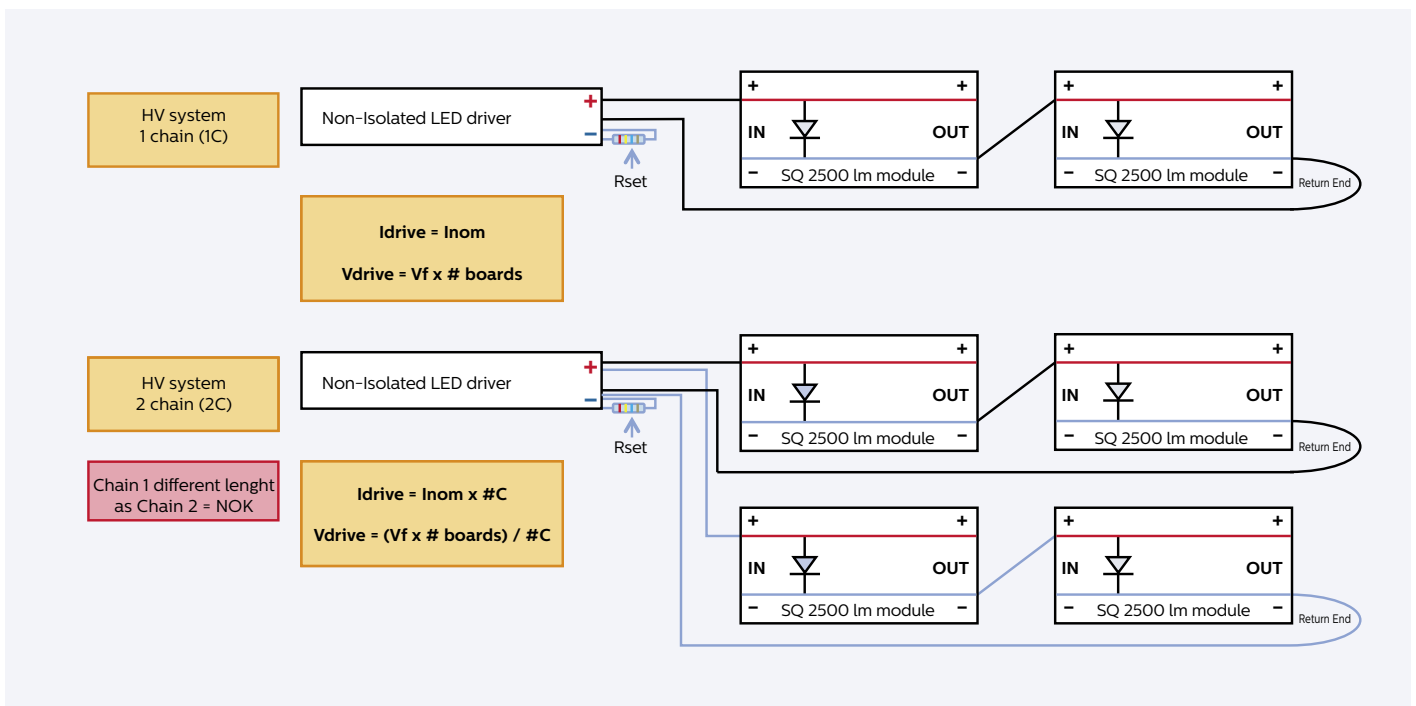
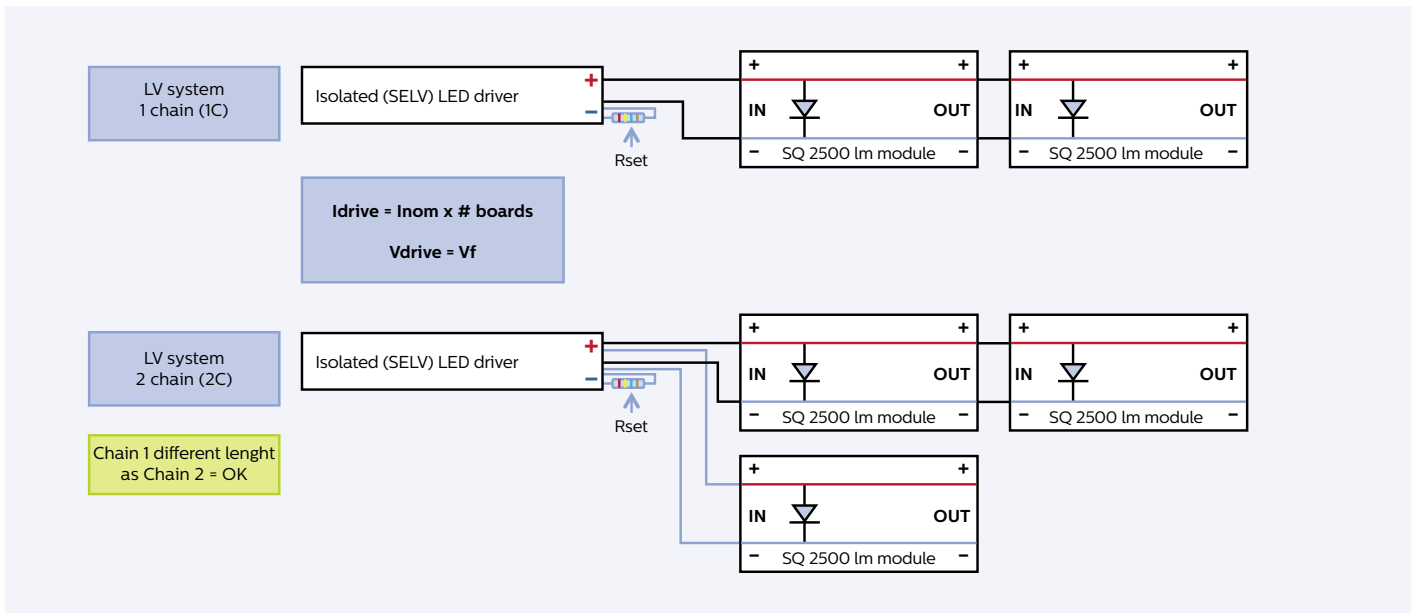



© 2015 Royal Philips N.V. All rights reserved. Philips reserves the right to make changes in specifications and/or to discontinue any product at any time without notice or obligation and will not be liable for any consequences resulting from the use of this publication.

09/2015
Data subject to change

www.philips.com/technology
www.philips.com/fortimo
www.philips.com/xitanium