

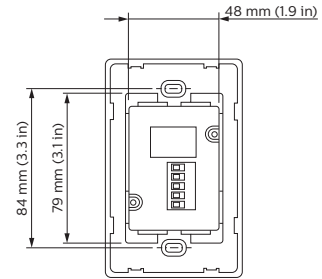

DPNA-SF Classic Series User Interfaces

Contemporary styling to suit any application

The Philips Dynalite DPNA-SF series user interfaces are a popular choice for commercial and residential applications, providing an integrated automation solution. The DPNA-SF range features a screwless fascia and is suitable for, but not limited to, North American, South American, Australian and New Zealand markets.



- Screwless fixing fascia — For use in applications where design aesthetic is a key consideration.
- Available in a range of finishes — Supplied as standard in high quality brushed stainless steel, user interfaces are also available in custom powder coat colors on request.
- LED status indicators on each button — Provides tactile and visual feedback on system operation.
- Removable button caps — Allows engraving for easy identification of button function.
- Button color choices — Supplied in silver as standard, with black bezel and black engraving, button caps are also available in charcoal grey as a standard option.
- Available in 13 standard layouts — Incorporates the most commonly used control scenarios.
- Custom features available — Optional devices including faders, displays, key switches, plug sockets and engraving are available for unique control solutions.

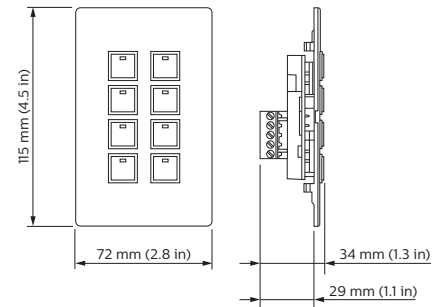

For detailed product information, please refer to the product information pages at www.philips.com/dynalite and follow the links.

Specifications

Due to continuous improvements and innovations, specifications may change without notice.

Item	Specification	Details
Electrical	DyNet DC Supply	12 VDC @ 20 mA from the DyNet network
	Control Inputs	One RS-485 DyNet serial port
Physical	Dimensions (H x W x D)	115 mm x 72 mm x 34 mm (4.5" x 2.8" x 1.3")
	Packed Weight	0.15 kg
	Construction	Plate: Stainless steel or solid brass Button: Metalized ABS plastic
	Operating Conditions	Temperature: -0 to 50° C ambient Humidity: 10 to 95% non-condensing
	Storage & Transport	Temperature: -25 to 60° C ambient Humidity: 0 to 90% non-condensing
Certification	Certification	CE, C-Tick
Options & Ordering		Contact your local Philips representative for ordering information.

Ordering - Standard User Interfaces

Supplied in stainless steel finish, silver button caps, black engraving & bezel.

Panel Configuration	Order Code
0 button with 1 DyNet network socket	DPNA308-SF
1 button ON/OFF toggle	DPNA914-SF
4 button preset 1-3, OFF	DPNA941-SF
6 button preset 1-3, ▲, ▼, OFF	DPNA963-SF
8 button preset 1-7, OFF	DPNA981-SF
8 button programming	DPNA982-SF
8 button programming with keyswitch	DPNA982D-SF
10 button preset, 1-7, ▲, ▼, OFF	DPNA9103-SF

Ordering - Stock Button Caps

Button caps are available in silver or charcoal

Engraving	Silver	Charcoal
None (blank)	DPN-CAP-SI-LED-BLANK	DPN-CAP-CH-LED-BLANK
1	DPN-CAP-SI-LED-1	DPN-CAP-CH-LED-1
2	DPN-CAP-SI-LED-2	DPN-CAP-CH-LED-2
3	DPN-CAP-SI-LED-3	DPN-CAP-CH-LED-3
4	DPN-CAP-SI-LED-4	DPN-CAP-CH-LED-4
5	DPN-CAP-SI-LED-5	DPN-CAP-CH-LED-5
6	DPN-CAP-SI-LED-6	DPN-CAP-CH-LED-6
7	DPN-CAP-SI-LED-7	DPN-CAP-CH-LED-7
8	DPN-CAP-SI-LED-8	DPN-CAP-CH-LED-8
9	DPN-CAP-SI-LED-9	DPN-CAP-CH-LED-9
10	DPN-CAP-SI-LED-10	DPN-CAP-CH-LED-10
11	DPN-CAP-SI-LED-11	DPN-CAP-CH-LED-11
12	DPN-CAP-SI-LED-12	DPN-CAP-CH-LED-12
13	DPN-CAP-SI-LED-13	DPN-CAP-CH-LED-13
14	DPN-CAP-SI-LED-14	DPN-CAP-CH-LED-14
15	DPN-CAP-SI-LED-15	DPN-CAP-CH-LED-15
▲	DPN-CAP-SI-UP	DPN-CAP-CH-UP
▼	DPN-CAP-SI-DOWN	DPN-CAP-CH-DOWN
ON	DPN-CAP-SI-LED-ON	DPN-CAP-CH-LED-ON
OFF	DPN-CAP-SI-LED-OFF	DPN-CAP-CH-LED-OFF
ON/OFF	DPN-CAP-SI-LED-ON/OFF	DPN-CAP-CH-LED-ON/OFF
MANUAL	DPN-CAP-SI-LED-MANUAL	DPN-CAP-CH-LED-MANUAL
DAY	DPN-CAP-SI-LED-DAY	DPN-CAP-CH-LED-DAY
NIGHT	DPN-CAP-SI-LED-NIGHT	DPN-CAP-CH-LED-NIGHT
SECURITY	DPN-CAP-SI-LED-SECURITY	DPN-CAP-CH-LED-SECURITY
CLEAN	DPN-CAP-SI-LED-CLEAN	DPN-CAP-CH-LED-CLEAN

CUSTOM ENGRAVED BUTTON CAPS

Engraving specified with order

Ordering - Non-Stock User Interfaces

Supplied in stainless steel finish, silver button caps, black engraving & bezel.

Panel Configuration	Order Code
2 button 2 room join keypad	DPNA926-SF
0 button keypad with 2 room join keyswitch	DPNA908J-SF
0 button keypad with 3 room join keyswitch	DPNA908J3-SF
4 button preset keypad with single fader	DPNA941F1-SF
4 button preset keypad with keypad enable keyswitch	DPNA941D-SF
4 button preset keypad with DyNet network socket	DPNA941N-SF
4 button preset keypad with 2 room join keyswitch	DPNA941J-SF
4 button preset keypad with 3 room join keyswitch	DPNA941J3-SF
4 button 3 room join keypad	DPNA946-SF
4 button 3 room join keypad with disable keyswitch	DPNA946D-SF
5 button preset 4 fader keypad	DPNA951F4-SF
5 button preset 6 fader keypad	DPNA951F6-SF
5 button preset 8 fader keypad	DPNA951F8-SF
5 button preset 12 fader keypad	DPNA951F12-SF
8 button preset with keypad enable keyswitch	DPNA981D-SF
8 button preset keypad with 2 room join keyswitch	DPNA981J-SF
8 button preset keypad with 3 room join keyswitch	DPNA981J3-SF
8 button preset keypad with DyNet network socket	DPNA981N-SF

Ordering - Alternate User Interface Finishes

User interfaces are supplied in brushed stainless steel as standard, but a range of alternate finishes are available.

Finish	Suffix
Custom powdercoat finish	DPNA***-PC



Philips Dynalite
6 / 691 Gardeners Road
Mascot, NSW 2020
Australia

Tel: +61 2 8338 9899

Email: dynalite.info@philips.com

Web: www.philips.com/dynalite

Specifications subject to change without notice. ©WMGD Pty Ltd Trading as Dynalite. Unit 6, 691 Gardeners Road Mascot 2020 Australia. ABN 33 097 246 921. All rights reserved. Dynalite, DyNet and associated logos are the registered trademarks of WMGD Pty Ltd. Not to be reproduced without permission.