



DUS804C-NA Multifunction Sensor

Low profile recessed 360° flush mount ceiling sensor

The DUS804C-NA is a recess mountable 360 degree multifunction sensor that combines motion detection (PIR), Infrared remote control reception (IR) and ambient light level detection (PE) into one device in applications such as offices, lecture theaters and homes.

- Motion detection feature — Detects the presence or absence of motion and adjusts lights accordingly.
- Segmented click-up bezel — Surrounds the motion sensor element and enables a portion of the sensing field to be masked. This prevents nuisance detection from adjacent doorways or corridors.
- Ambient light level detection and daylight harvesting — In applications where it is critical to maintain precise light, the PE function reads ambient levels and adjusts artificial light accordingly.
- Infrared receive capability — Manually adjust light levels using a hand-held remote control, via the inbuilt IR receive sensor of the DUS804C-NA.
- Daylight Harvesting mode — Programmable as open or closed loop to deliver automatic energy savings.

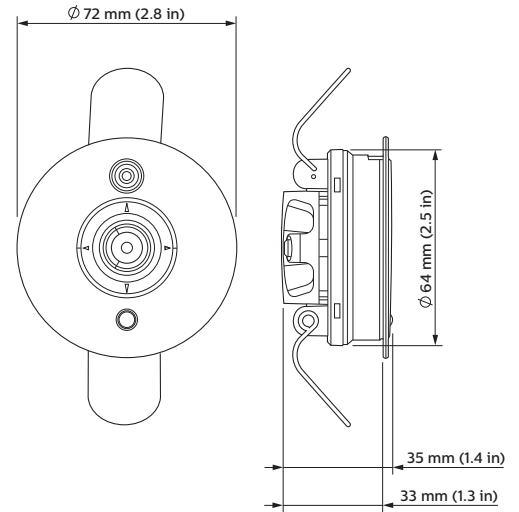

For detailed product information, please refer to the product information pages at www.philips.com/lightingcontrolsna.

Specifications

Due to continuous improvements and innovations, specifications may change without notice.

Item	Specification	Details
Hardware	Motion Detector	Maximum detection range: 16' (5 m) Detection area: 24' x 18' (7.4 m to 5.6 m) rectangular (at a height of 8' (2.5 m)) Detection speed: 13.3 ft/s (1.0 m/s) Detection object: 2.2' x 0.8' (700 mm x 250 mm) Detection zones: 64 LED activation indicator Sensor: Quad element pyroelectric
	PE Cell	Range: 5 - 500 lux (incident on sensor), <5 lux to >5000 lux (illumination of non-reflective surface in sensor's field of view). NB value subject to reflectance properties of surface Automatic 'Daylight Harvesting' mode
	Infrared Remote Control Receiver	Range up to 19' (6 m), angle dependant LED activation indicator Can be used with DTK500 series infrared remotes or other learning IR remote control
	Terminals	5 way terminal strip, 1 x 14 AWG or 2 x 18 AWG max. conductor size
	Controls	Walk test/IR received LED indicator Tamper switch
Network	Control Inputs/Outputs	One RS-485 DyNet serial port
	DyNet DC Load	10 mA max. @ 24 VDC
	Configurations	All functions remotely programmable
Physical	Dimensions (H x W x D)	4.8" dia. x 1.4" (72 mm dia. x 35 mm)
	Packed Weight	0.3 lbs (0.116 kg)
	Construction	ABS plastic enclosure
	Operating Conditions	Temperature: 32 to 113° F (0 to 45° C) ambient Humidity: 10 to 90% non-condensing
	Storage & Transport	Temperature: -13 to 140° F (-25 to 60° C) ambient Humidity: 0 to 90% non-condensing
Certification	Certification	FCC, RoHS Compliant
Options & Ordering	Standard Product CAT5/CAT6 Wiring Adapter	DUS804C-NA (Philips 12NC - 913703570109) DRJ485ADAPT

Lens Pattern

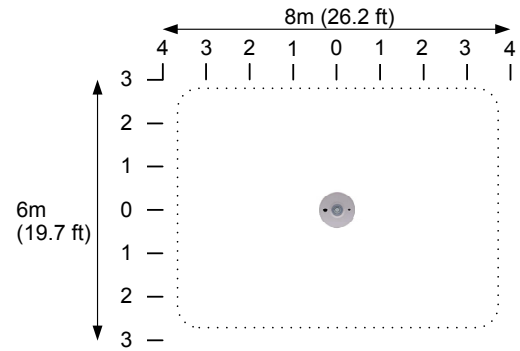

Philips Lighting North America
 200 Franklin Square Dr
 Somerset, NJ, United States
 Tel: 1-800-526-2731
 Email: controls.support@philips.com
 Web: www.philips.com/lightingcontrolsna

Philips Lighting Canada
 281 Hillmount Road
 Markham, Ontario L6C 2S3
 Canada

Specifications subject to change without notice. © WMGD Pty Ltd Trading as Dyalite. Unit 6, 691 Gardeners Road Mascot 2020 Australia. ABN 33 097 246 921. All rights reserved. Dyalite, DyNet and associated logos are the registered trademarks of WMGD Pty Ltd. Not to be reproduced without permission.