

PHILIPS

Sensors

EasySense

Outboard-Mount for High Bay



Philips EasySense for high bay is the ideal solution for per-fixture control of new light fixtures for industrial high bay applications. It combines occupancy sensing, daylight harvesting and task tuning in a single, compact package for easy OEM fixture assembly or installation in the field. EasySense operates with the established Philips Advance Xitanium SR LED Drivers through a simple two-wire connection between sensor and driver, thus eliminating the need for multiple components and auxiliary devices. The result is a cost-effective and easy-to-design-in solution ideal for energy-savings and code-compliance strategies. The intuitive Philips field apps for Android smartphones makes onfiguration and commissioning during and after installation fast and easy.

EasySense includes advanced grouping functionality which enables occupancy sharing and zoning capability. Up to 40 sensors can be operated together in a group, and the group can then be divided into a maximum of 6 zones. With this advanced functionality, the group can be programmed such that a zone comes up to full light level upon motion detection while other zones come up to a lower background light level. This enhances energy savings while still providing lighting in adjacent areas.

A primary benefit of EasySense for high bay is that it does not require gateways, network connections or dashboards. The sensors in the group communicate to each other via Zigbee for simple area-based control. It is an uncomplicated means to achieve energy savings and code compliance for industrial high bay applications while maintaining aesthetics in the space.

Commercial Product Name	Order Code
EasySense Outboard-Mount for High Bay	SNH200

EasySense for high bay

Features

- Occupancy sensing, daylight harvesting and task tuning in one device
- Occupancy sharing, 40 sensors max per group per, 6 zones max per group
- Compact size, 2-wire connection
- Operates with Philips Advance Xitanium SR LED drivers and qualified wireless switches
- Configuration of sensor parameters – if desired – using NFC or IR via Android-based Philips field apps
- 15 to 52.5 foot mounting height; IP65 rated

Benefits

- Combines functionality to reduce need for multiple components
- No need for gateways or centralized control
- Quick task tuning in the field to optimize light and power levels
- Cost-effective solution for energy-savings and code-compliance strategies
- 5-year limited system warranty with Philips Advance Xitanium LED drivers¹
- Ease of configuration and commissioning from the floor

Applications

- Warehouses
- Assembly areas
- Cold storage

Product Data

Ordering Information	
Order Code	SNH200
Full Product Name	EasySense High Bay Sensor
Carton Quantity	Individual carton (20 per master case)
Physical Information	
Overall Dimensions	Refer to drawing
Housing (Luminaire Hole)	½" threaded nipple for ½" knockout
Net Weight per Piece	185gm / 6.5oz
Color	Gray housing, translucent cover
Wiring	(2) 18AWG wires, unpolarized; 60cm length; 8mm strip length
Electrical Information	
Input Voltage	Powered by SR driver low voltage interface
Current Consumption	45mA
Nominal Power Consumption	200mW
Standby Power	<1W at fixture level including driver standby power
Occupancy Sensing	
Type	Passive infrared (PIR)
Enable/Disable	Enabled by default
Occupancy Mode	Auto-on/auto-off; Manual-on/auto-off ; Manual-on / manual-off
Group Occupancy Sharing	Enabled/disabled
Group Lighting Behavior	Background level/task level
Eco-On Level	5% - 100%
Hold Time	30 seconds - 60 minutes
Viewing Angle	±30°
Background Light Level	0% - 100%
Prolong Time	0 minutes - 150 minutes, or infinite
Grace Fading	0 seconds - 25 seconds
Response Time/Fading to Switch On/Off	0.7 seconds
Sensitivity	High / medium / low (refer to design-in guide for detailed guidelines)

Continued on next page.

1. View limited warranty at <http://www.usa.lighting.philips.com/support/support/warranty>.

EasySense for high bay

Product Data (continued)

Daylight Sensing	
Enable/Disable	Disabled by default
Auto-Calibration	Upon power-up; disabled when daylight sensing is disabled
Viewing Angle	+/- 10°
Minimum Dim Level	Background level or minimum dim level programmed in driver, whichever is higher; Lighting will not shut off
Task Tuning	
Full Light Setting	5% - 100%
Environment & Approbation	
Operating Ambient Temperature Range	-25°C to +65°C
Ingress Rating	IP65
Operating Humidity	20% to 85% relative humidity, non-condensing
Storage Temperature	-25°C to +85°C
Max Case Temperature (Tcase)	+65°C
Agency Approbations	UL, CSA, FCC
Certification	UL 916
Warranty	5 years
Digital Interface	Xitanium SR
Other	
Wireless Protocol	Zigbee, IEEE 802.15.4
Encryption	AES-128
No. Drivers per Sensor	4 max. (SR drivers only)
Max Distance Switch-to-First Sensor	50ft/15m line-of-site
Max Distance Sensor-to-Sensor	50ft/15m line-of-sight
No. Sensors per Group	40 max.
No. of Zones per Group	6 max.
No. Sensors per Zone	40 max.
No. Switches per Group/Sensor	5 max.
Mounting Height	15 to 52.5ft / 4.5m to 16m
Field Configuration	via NFC or IR, parameters set via Philips field apps; Configuration via IR requires a specific IR dongle from Philips

Compatible LED Drivers

Driver Model Number	Description
XI040C110V054VPT1	Xitanium 40W 0.1-1.1A 27-54V 120-277V SR
XI075C200V054VPT1	Xitanium 75W 0.1-2.0A 27-54V 120-277V SR
XI075C070V118VSY1	Xitanium 75W 0.07-0.70A 43-118V 120-277V SR with AUX
XI075C105V079VSY1	Xitanium 75W 0.105-1.05A 32-79V 120-277V SR with AUX
XI095C275V054VVPF1	Xitanium 95W 0.03-2.75A 27-54V 120-277V SR
XI095C275V054VVSF1	Xitanium 95W 0.03-2.75A 27-54V 120-277V SR with AUX
XI150C070V235VSF1	Xitanium 150W 0.07-0.70A 78-235V 120-277V SR with AUX
XI150C105V157VSF1	Xitanium 150W 0.105-1.05A 44-157V 120-277V SR with AUX

Specifications available at www.philips.com/xitaniumsr/na.

EasySense for high bay

Sensor Dimensions, mm [in]

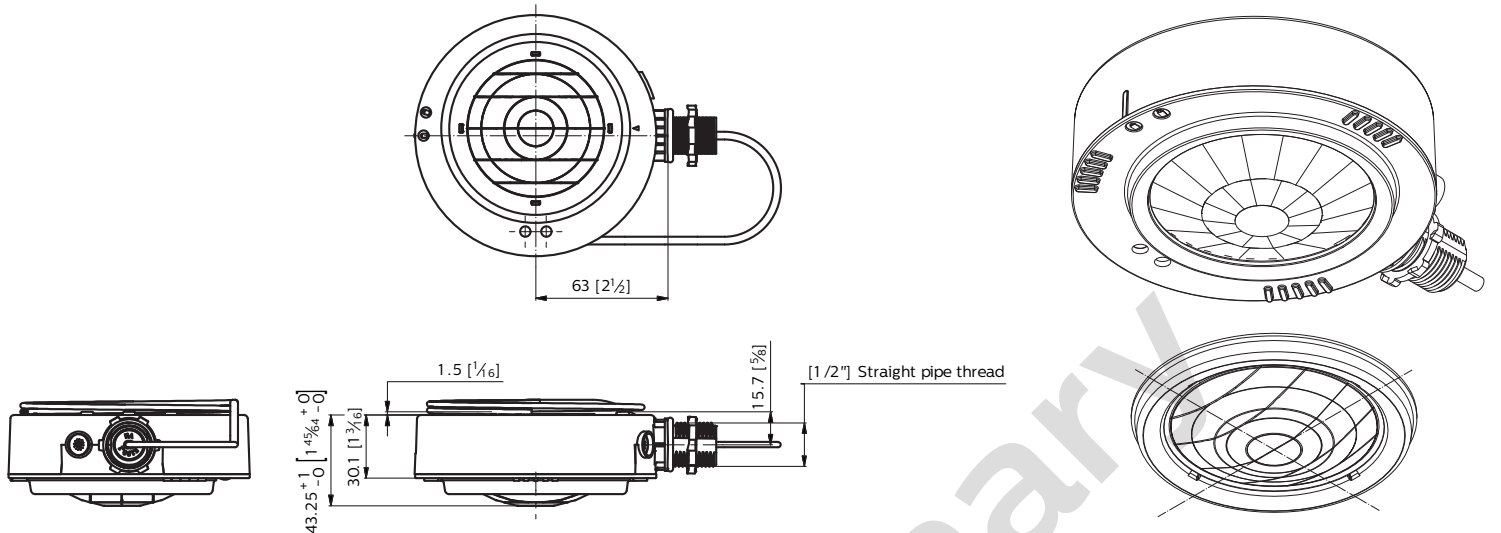

Optional view shield (included). Refer to design-in guide for details on coverage patterns when using view shield.

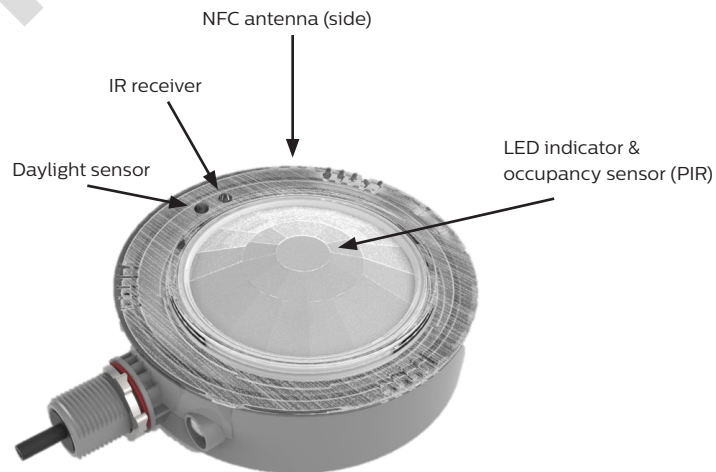
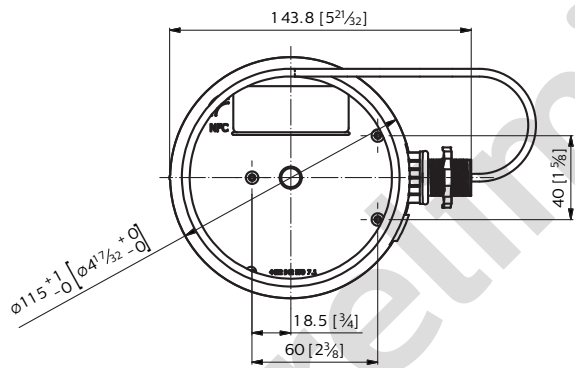

EasySense for high bay

Wiring Diagram

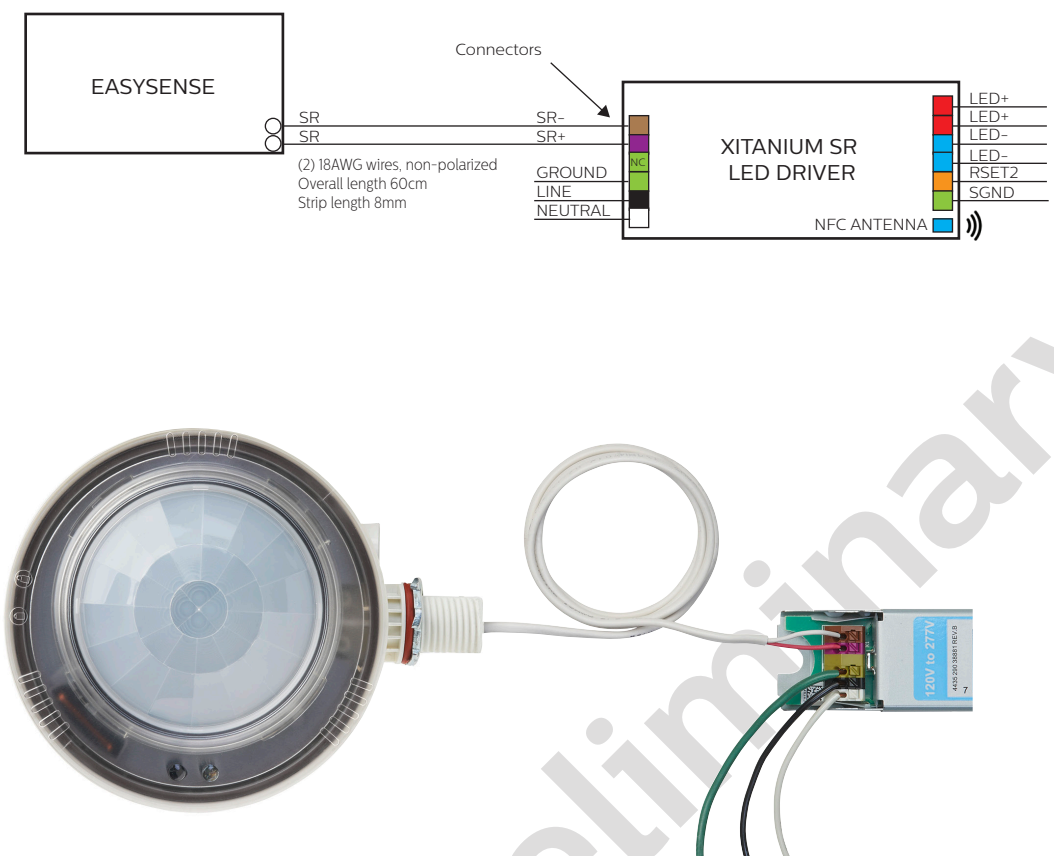

Note: Above depicts connecting wires from sensor to Xitanium SR drivers that include connectors. For connection to Xitanium SR drivers that include leads, use wirenuts suitable for 18AWG solid wire.

EasySense for high bay

Occupancy Sensing

Based on 16m mounting height

Top coverage

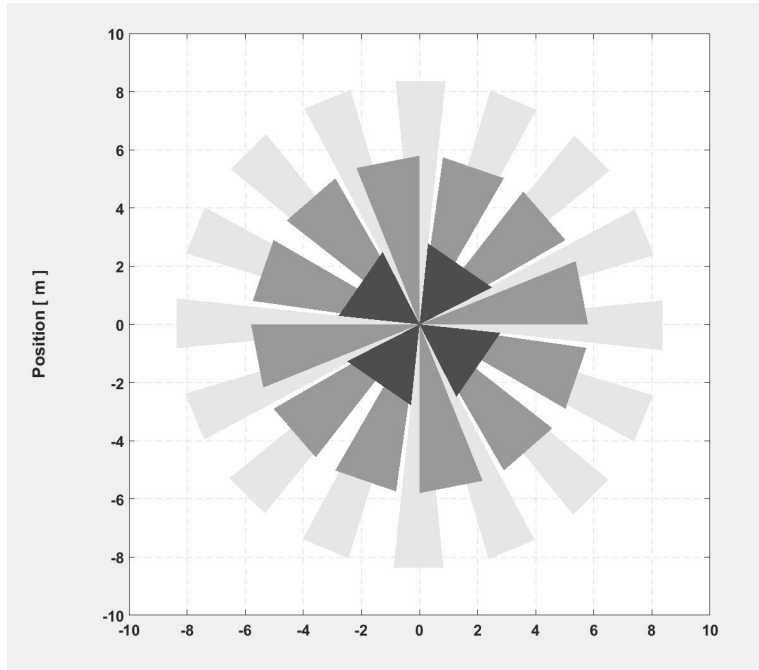

Side coverage

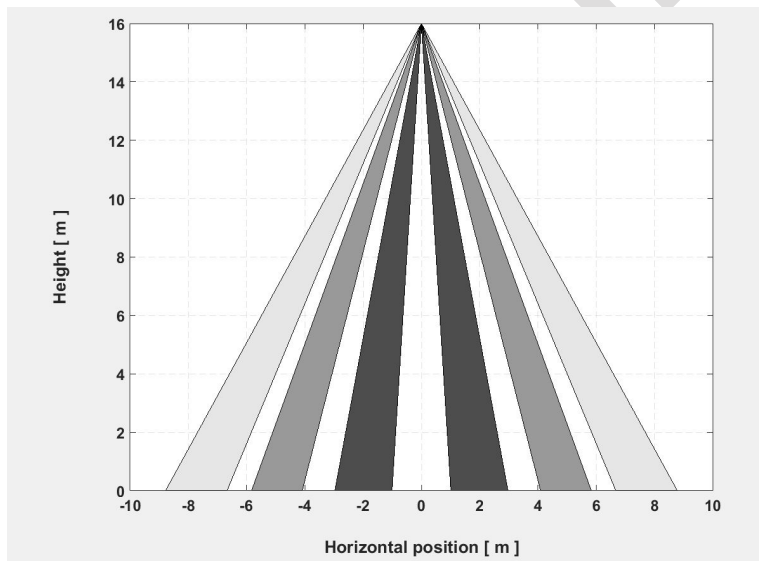

Note: Above coverage patterns depict sensor without optional view shield. Refer to design-in guide for details on coverage patterns when using view shield.

EasySense for high bay

Occupancy Sensing (continued)

Full-On Sequence (Default)

Eco-On Level = Task Level

Eco-on level/Task Level (configurable)

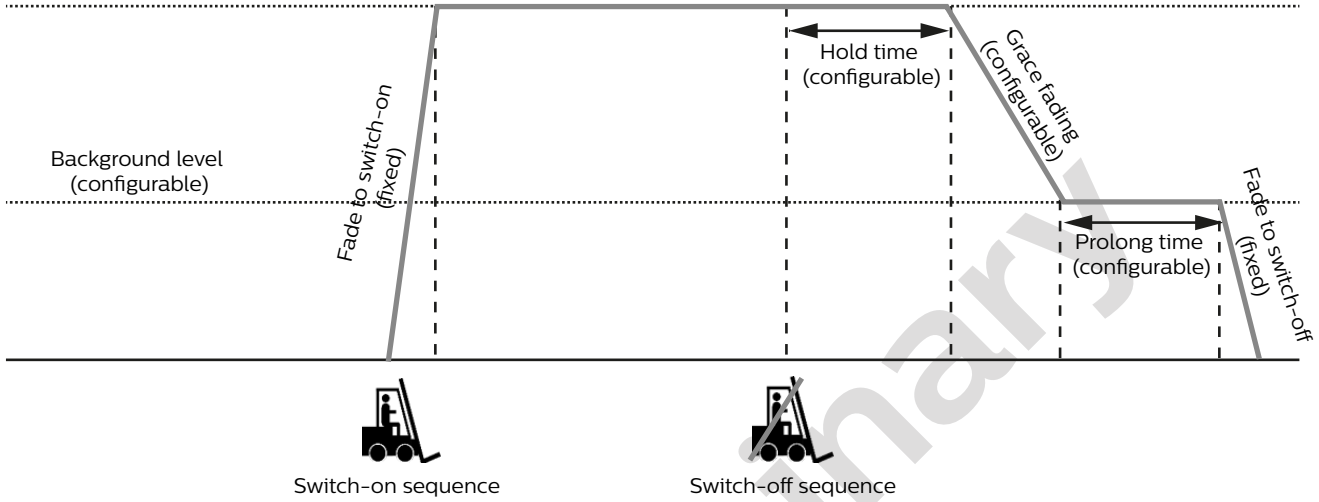

Partial-On Sequence (Configurable)

Eco-On Level < Task Level

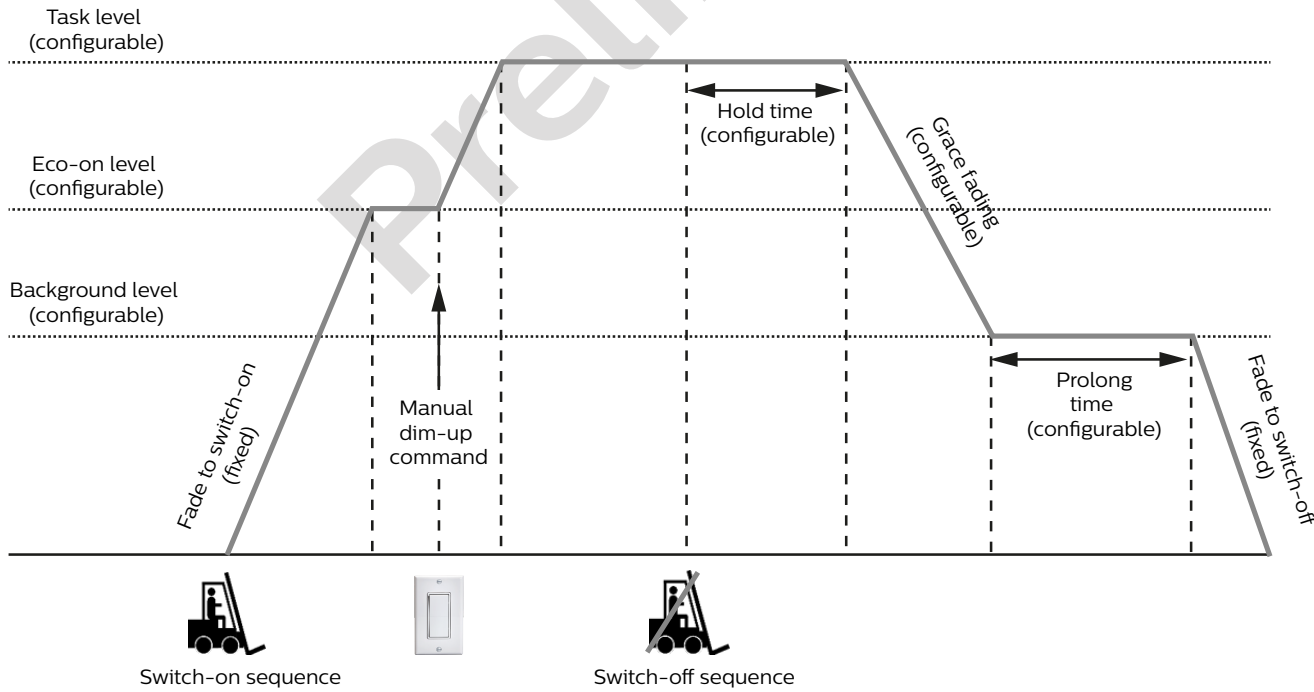

EasySense for high bay

Daylight sensor

The light sensor measures the total amount of light in a circular field of $\approx 80\%$ of the PIR detection area. The following aspects should be observed during installation:

- Minimum distance from the window $\geq 2.0/0.6\text{m}$.
- Prevent light reflections from outside entering the sensor (for example sunlight reflection on a car bonnet) as this will lead to incorrect light regulation.

As a guideline the formula $0.72 \times H$ can be used to calculate the minimum distance between the window and sensor whereby H is the height from the bottom of the window to the ceiling.

Photosensor spatial response

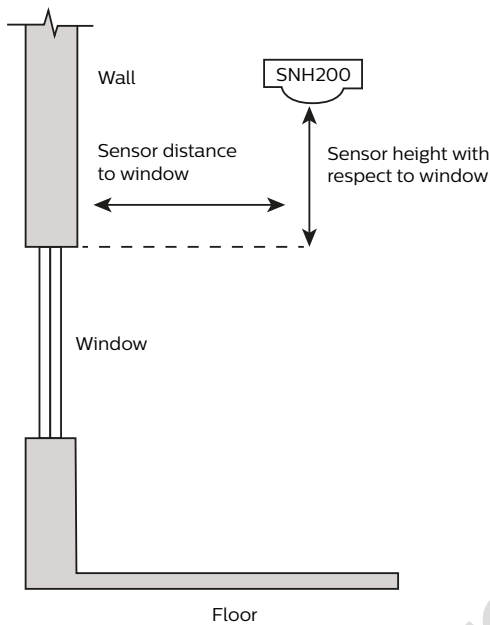

Minimum distance versus mounting height

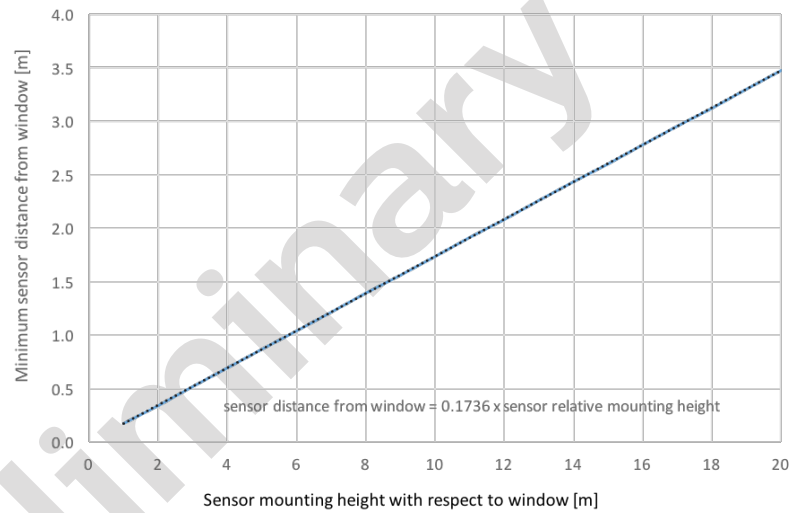

Note: Restrictions only for daylight regulation. No restrictions for skylights.

Photosensor spectral response

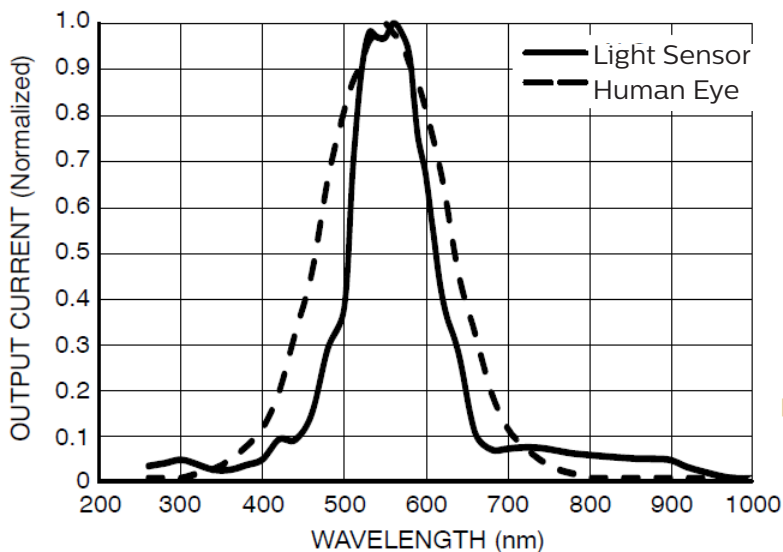

EasySense for high bay

Philips Field Apps: EasySense NFC and EasySense IR

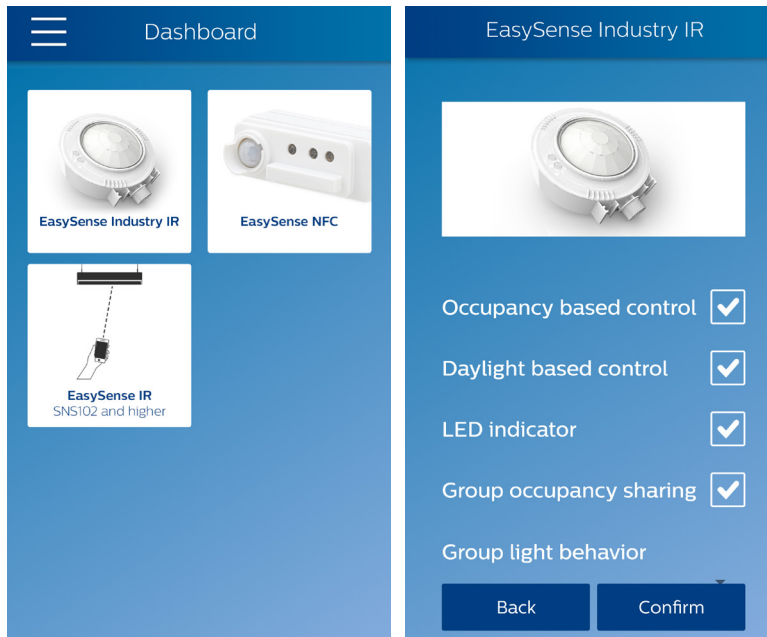

Note: Use of IR requires a specific IR dongle from Philips to configure and group from floor level. Consult your Philips representative.

EasySense parameters can be configured via Philips field apps available for Android phones. Two options are available:

1. EasySense NFC – This app allows configuring EasySense parameters only when you can physically access the sensor with a smartphone.
2. EasySense Industry IR – This app allows configuring EasySense parameters plus enables grouping to a wireless switch, which can be done with an Android phone and a specific IR dongle from Philips.

You must first register for Philips field apps to receive a username and password, then download Philips field apps from the Google Play Store. Refer to www.philips.com/easysense for details, including applicable Android phones and user manuals.

Default Factory Settings

Occupancy Detection	Auto-on, Enabled
Daylight-Based Control	Auto-on, Disabled
LED Indicator	Enabled
Occupancy Mode	Auto-on/off
Occupancy Detection Sensitivity	High
Group Occupancy Sharing	Enabled
Group Lighting Behavior	Background level
Field Task Tuning	100%
Eco-On Level	100%
Background Light Level	20%
Hold Time	15 minutes
Prolong Time	15 minutes
Grace Fading	10 seconds
Fade to Switch-On	0.7 seconds
Fade to Switch-Off	0.7 seconds

EasySense for high bay

Compatible Wireless Switches

Manufacturer	Model	Style
Illumra	ZBT-S1AWH	Single Rocker Self Powered
	ZBT-S2AWH	Dual Rocker Self Powered
Magnum Energy Solutions	MZ-SW1	Single Rocker Self Powered
	MZ-SW2	Dual Rocker Self Powered
	MZ-ASW1	Single Rocker Self Powered
	MZ-ASW2	Dual Rocker Self Powered
	MZ-ESRP	Single Rocker Self Powered
	MZ-EDRP	Dual Rocker Self Powered

- Max no. sensors per switch: 40
- Manufacturers links to product information:
 - o Illumra (www.illumra.com/easysense)
 - o Magnum Energy Solutions (www.magnumenergysolutions.com/products)

Single-Rocker Functions (typical switch shown)

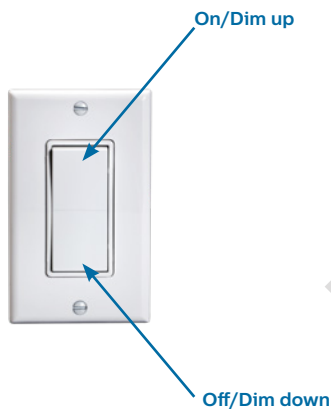

Dual-Rocker Functions (typical switch shown)

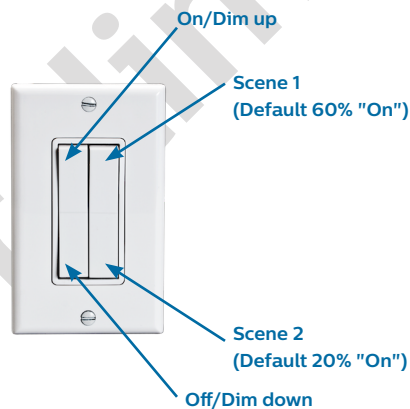

© 2018 Philips Lighting Holding B.V. All rights reserved.
 Philips reserves the right to make changes in specifications and/or to discontinue any product at any time without notice or obligation and will not be liable for any consequences resulting from the use of this publication.
philips.com/easysense



Philips Lighting North America Corporation
 10275 W. Higgins Road, Rosemont IL 60018
 Tel: 800-322-2086 Fax: 888-423-1882
 Customer/Technical Service: 800-372-3331
 OEM Support: 866-915-5886

Philips Lighting Canada Ltd.
 281 Hillmount Rd, Markham, ON, Canada L6C 2S3
 Tel. 800-668-9008