

# Showline

## SL LEDSPOT 300 Automated Luminaire

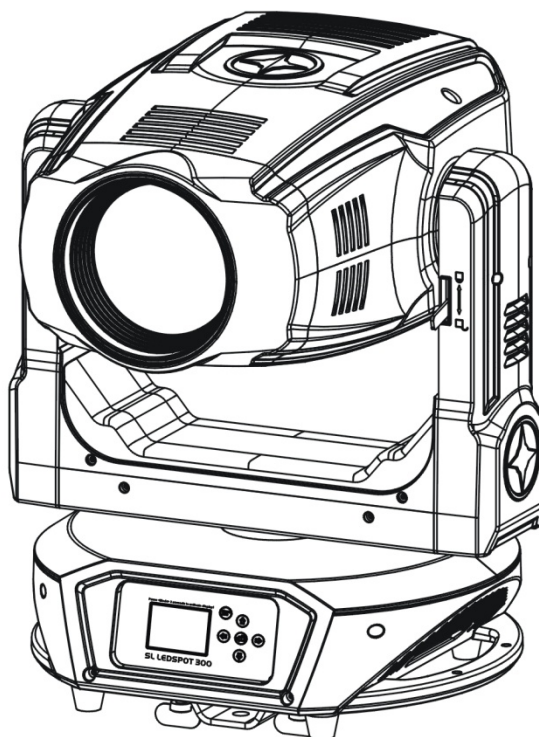

## Showline Offices

### Dallas

10911 Petal Street  
Dallas, TX 75238  
Tel: +1 214-647-7880  
Fax: +1 214-647-8030

### Asia

Unit C, 14/F, Roxy Industrial Centre  
No. 41-49 Kwai Cheong Road  
Kwai Chung, N.T., Hong Kong  
Tel: +852 2796 9786  
Fax: +852 2798 6545

### Auckland

19-21 Kawana Street  
Northcote, Auckland 0627  
New Zealand  
Tel: +64 9 481 0100  
Fax: +64 9 481 0101  
Europe  
Rondweg zuid 85  
Winterswijk 7102 JD  
The Netherlands  
Tel: +31 (0) 543-542516

[www.philips.com/showline](http://www.philips.com/showline)

The material in this manual is for information purposes only and is subject to change without notice. Showline assumes no responsibility for any errors or omissions which may appear in this manual. For comments and suggestions regarding corrections and/or updates to this manual, please contact your nearest Showline office.

El contenido de este manual es solamente para información y está sujeto a cambios sin previo aviso. Showline no asume responsabilidad por errores o omisiones que puedan aparecer. Cualquier comentario, sugerencia o corrección con respecto a este manual, favor de dirijirlo a la oficina de Showline más cercana.

Der Inhalt dieses Handbuchs ist nur für Informationszwecke gedacht, Aenderungen sind vorbehalten. Showline uebernimmt keine Verantwortung für Fehler oder Irrtuemer, die in diesem Handbuch auftreten. Für Bemerkungen und Verbesserungsvorschlaege oder Vorschlaege in Bezug auf Korrekturen und/oder Aktualisierungen in diesem Handbuch, moechten wir Sie bitten, Kontakt mit der naechsten Showline-Niederlassung aufzunehmen.

Le matériel décrit dans ce manuel est pour information seulement et est sujet à changements sans préavis. La compagnie Showline n'assume aucune responsabilité sur toute erreur ou omission inscrite dans ce manuel. Pour tous commentaires ou suggestions concernant des corrections et/ou les mises à jour de ce manuel, veuillez s'il vous plait contacter le bureau de Showline le plus proche.

---

**Note:** Information contained in this document may not be duplicated in full or in part by any person without prior written approval of Philips. Its sole purpose is to provide the user with conceptual information on the equipment mentioned. The use of this document for all other purposes is specifically prohibited.

---

**CAUTION:** Replace the lenses if they have become visibly damaged to such an extent that their effectiveness has become impaired, for example by cracks or deep scratches.

---

SL LEDSPOT 300 Luminaire QuickStart Guide

©2016 Philips Group. All rights reserved.

## Special Product Information

In addition to the information contained in "Warnings and Notices" on page4, please read the special product information below.



---

**CAUTION:** Risk Group 3. Possible hazardous optical radiation may be emitted from the products described herein. Do not stare directly into light sources. May be harmful to the eyes.

---



---

**Note:** The light source contained in this luminaire shall only be replaced by the manufacturer, authorized service center or similar qualified person

---



---

**CAUTION:** Replace the lenses if they have become visibly damaged to such an extent that their effectiveness has become impaired, for example by cracks or deep scratches.

---



# Table of Contents

Showline Offices .....	1
Special Product Information .....	1
Introduction .....	3
About Quickstart Guide .....	3
Included Items .....	3
Warnings and Notices .....	3
Service and Maintenance .....	3
Power Requirements .....	3
AC Power Operation .....	3
Connecting Power .....	4
AC and DMX Input / Output Connections .....	5
Connecting to the DMX Network .....	5
Mounting Luminaire .....	5
Floor .....	5
Floor Mounting .....	5
Menu System .....	6
LCD Display Menu .....	6
LCD Display and Menu System Operation .....	6
Menu Settings .....	6
DMX CONTROL .....	8
SL LEDSPOT 300 Luminaire DMX Mapping .....	8
Product Specifications .....	14
Features .....	14
Color System .....	14
Gobos / Effects .....	14
Prisms .....	14
Zoom: .....	14
Power Consumption .....	14
Movement .....	15
Safety distance .....	15
Weight .....	15
AC Power Input .....	15
Luminaire Dimensions .....	16

## Introduction

### About Quickstart Guide

This Quickstart Guide is intended for a knowledgeable user to unpack, install, and use SL LEDSPOT 300 in a short time period. For the complete manual in PDF format, please visit our web site at :[www.philips.com/showline](http://www.philips.com/showline) and click the user manual download link on the product page. The complete manual provides you all information related to accessories, menu structures, DMX channel mapping/modes, and care for your new luminaire.

### Included Items

Each SL LEDSPOT 300 includes the following items:

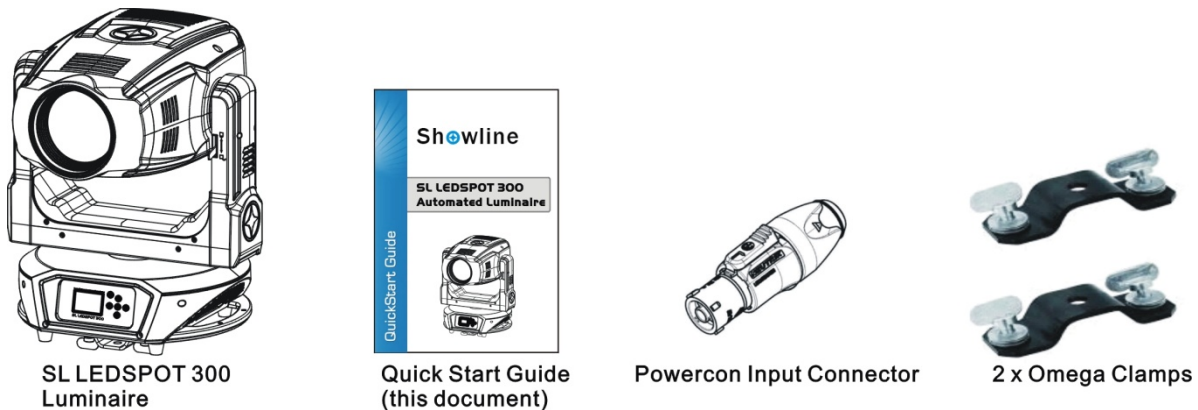

Figure 1: Included Items

### Warnings and Notices



When using electrical equipment, basic safety precautions should always be followed including the following:

**READ AND FOLLOW ALL SAFETY INSTRUCTIONS.**

- Do not use outdoors.
- Do not mount near gas or electric heaters.
- Equipment should be mounted in locations and at heights where it will not readily be subjected to tampering by unauthorized personnel.
- The use of accessory equipment not recommended by the manufacturer and may cause an unsafe condition..
- Do not use this equipment for other than intended use.
- Refer service to qualified personnel.

**SAVE THIS DOCUMENT FOR FUTURE REFERENCE! READ COMPLETELY BEFORE INSTALLING AND USING PRODUCT!**



**WARNING:** You must have access to a main circuit breaker or other power disconnect device before installing any wiring. Be sure that power is disconnected by removing fuses or turning the main circuit breaker off before installation. Installing the device with power on may expose you to dangerous voltages and damage the device. A qualified electrician must perform this installation.

**WARNING:** Refer to National Electrical Code® and local codes for cable specifications. Failure to use proper cable can result in damage to equipment or danger to personnel.

**WARNING:** This equipment is intended for installation in accordance with the National Electric Code® and local regulations. It is also intended for installation in indoor applications only. Before any electrical work is performed, disconnect power at the circuit breaker or remove the fuse to avoid shock or damage to the control. It is recommended that a qualified electrician perform this installation.

### Service and Maintenance

For all service and maintenance issues, please contact your local Showline office or an Authorized Service Center.

### Power Requirements

The SL LEDSPOT 300 operates on AC input voltages from 100 to 240 V AC.



**WARNING:** This unit does not contain an ON/OFF switch. Always disconnect power input cable to completely remove power from unit when not in use.

### AC Power Operation

When connected to an AC source, the unit operates on 100 to 240 volts AC (+/- 10%, auto-ranging). The luminaire contains an auto-ranging power supply.

Each luminaire can draw up to 450 Watts.



**WARNING:** Maximum amount of units that may be daisy-chained is (A) 2 units AC 100V~(5.3Amps) or (B) 4 units AC 240V~ (2.08 Amps). Refer to Table 1 for detailed information at various voltages.



**Note:** For wiring of AC input connector, refer to Connecting SL LEDSPOT 300 to AC Power.

**Table 1: SL LEDSPOT 300 Voltage vs. Current**

Voltage(AC)	Total Current(A)	Maximum Number of units that can be linked together*
100	4.199	2
110	3.784	2
120	3.446	2
220	1.869	4
230	1.793	4
240	1.724	4



**WARNING:** \*These figures are based on the Maximum Allowable Input Current of each fixture (and the Maximum power supply limit of 450 Watts ). Do not overload circuits!



### IMPORTANT AC POWER CONNECTION NOTES:

- When using the daisy-chain connection method, only connect the SL LEDSPOT 300 to the AC Output connection of another SL LEDSPOT 300 luminaire.
- DO NOT CONNECT OTHER TYPES OF LUMINAIRES OR DEVICES!
- Only use approved cable types.
- Do not overload circuits!
- Do not connect the SL LEDSPOT 300 to dimmed circuits.

## Connecting Power

Units can be powered in one of two ways:

- Direct connection to a AC power source using an AC input cable. For wiring of AC input connector, refer to Connecting SL LEDSPOT 300 to AC Power.
- Connection from the AC output of another SL LEDSPOT 300. When using this method, it is very important not to connect any other type of equipment.



**WARNING:** Only connect other SL LEDSPOT 300 luminaires to the AC Output (Thru) connector of another SL LEDSPOT 300.

## Connecting SL LEDSPOT 300 Luminaires to AC Power

Table 2, AC Input Connections describes how to connect power to your SL LEDSPOT 300. Field wiring of the SL LEDSPOT 300 is straight-forward.

A total of 3 wires/conductors is supplied to this unit.

**Table 2: AC Input Connections**

Wire Color	Purpose
Black	Main/Line(100 to 240 VAC)
White	Neutral
Green	Ground(Earth)

### AC Input Connector (on Unit)

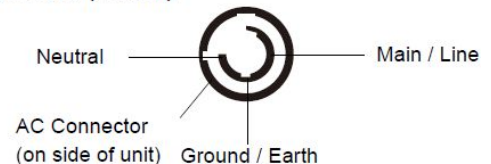

### AC Output Connector (on Unit)

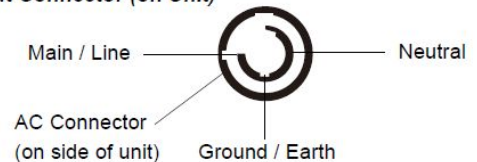

## AC and DMX Input / Output Connections

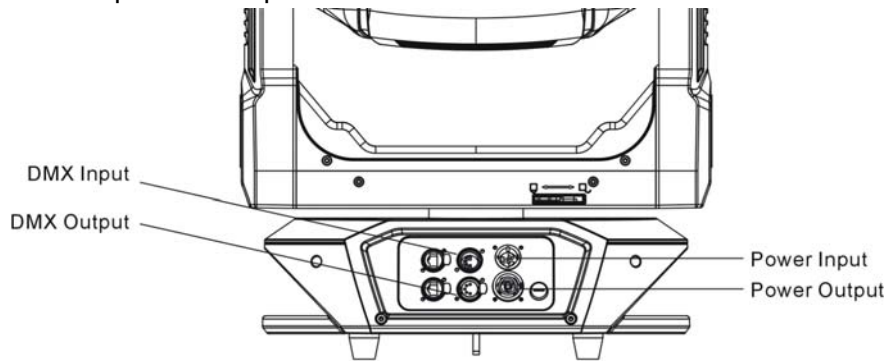

Figure 2: AC Input and Output connection

## Connecting to the DMX Network

Basic DMX512 installation consists of connecting multiple SL LEDSPOT 300 luminaires together (up to 32 luminaires) in "daisy-chain" fashion. A cable runs from the control console (or DMX512 control source) to the DMX connector on the first SL LEDSPOT 300 Luminaire. Another cable runs from the other DMX connector on the first unit to a DMX connector on the next SL LEDSPOT 300 Luminaire (or DMX512 device to be controlled).

Table 3: DMX512 Connections

DMX512 Signal	XLR Pin
Common (Drain)	1
DMX512-	2
DMX512 +	3

Note: Remaining pins on each connector are not used.

## Mounting Luminaire

The SL LEDSPOT 300 Luminaire is provided with the ability to hang via truss hooks, clamps, etc. (sold separately). Install Omega Clamps and attach hook, clamp, etc. to the Omega Clamps in the provided mounting holes. It is recommended (and may be required by local and national safety codes) to use and install a safety cable (included with unit) in the safety cable anchor point. When hanging the fixture, be sure to leave enough space around the luminaire to allow for free movement and uninterrupted airflow for cooling.

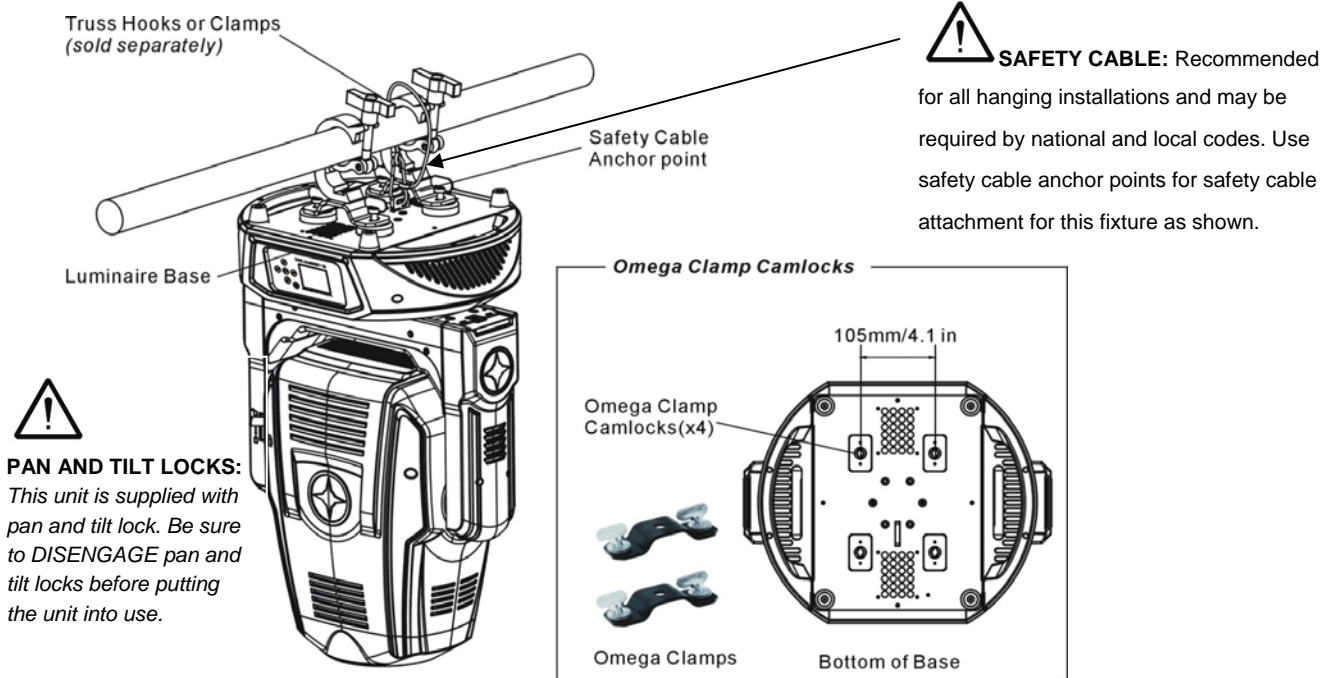

Figure 3: Mounting Luminaire

## Floor Mounting

The SL LEDSPOT 300 Luminaire is designed to sit directly on its base (Omega Clamps must be removed) in a floor installation application. When used in this type of application, be sure to leave enough space around the luminaire to allow proper, uninterrupted airflow for cooling and movement.



# Menu System

## LCD Display Menu

The SL LEDSPOT 300 Luminaire's LCD Display and Menu System provides local control for accessing the fixture's settings:



**Note:** If there are multiple luminaires in a system, changes would need to be made at each LCD Menu as desired.

Upon power up, the LCD will display the main screen showing the product name. If DMX is enabled, the programmed address will appear after power up.

**LCD Display-** Shows menu settings, error codes, address, etc.

**MODE/ESC (Escape) Button -** Used to access modes and settings menus.



**Arrow Button - UP | DOWN | LEFT | RIGHT -** Used to navigate through menu settings and options.

**Enter Button -** Used to enter a menu option or accept a menu setting change.

**Figure 4: LCD Display and Menu System**

## LCD Display and Menu System Operation

The LCD Display Menu system consists of several categories. Use the Menu Buttons to access and make changes to the menu items. When the desired menu item is reached, press the desired Menu Button to display the menu options and to navigate and configure the menu options as required.

**To navigate and access menu settings/selections:**

- Step 1. Make sure unit is powered on.
- Step 2. Press the desired button ( as shown in Figure 4) to access menu categories.
- Step 3. Use UP/DOWN/LEFT/RIGHT buttons to navigate through the various options and settings.
- Step 4. Make changes as desired.
- Step 5. Press RETURN button to accept changes.

## Menu Settings

The following menu settings and options are available in the SL LEDSPOT 300 Luminaire menu system.

**Table 4: Menu Setting**

First Level	Second Level	Third Level	Description
Function	Set Dmx Address	001-XXX	Sets the DMX Address. 001 is default value.
	Dmx Value	ALL: or Control	Displays DMX values for various parameters. ALL: is default.
	Auto Program		Simple ten step Factory pre-programmed colour and movement chase.
Information	Time Information	Current Time XXXX(Hours)	Running time since unit was powered on.
		Total Run Time XXXX(Hours)	Total hours fixture has run.
		Last Run Time XXXX(Hours)	Fixture running time since last clear of hours.
Last Run Password XXX		Entered to clear fixture timer. Password is "038"	
	Clear Last Run ON or OFF	Clears fixture last run time. Default is OFF.	
Temperature Info	Head Temperature XXX°C/°F	Displays current temperature of the luminaire head.	
Ethernet IP	Ethernet IP xxx.xxx.xxx.xxx	Displays luminaire's IP address.	

	Fan Info	Fan Info 2U01_Fan1: XXXRPM 2U01_Fan1: XXXRPM :	Displays fans RPM / status	
	Software Version	1U01: V1.0.0 2U01: V1.0.0 :	Displays software installed in luminaire.	
Personality	Status Settings	No DMX Status CLOSE / HOLD / AUTO Pan Reverse ON or OFF Tilt Reverse ON or OFF	Defines fixture behaviour on loss of DMX signal. Default is HOLD. Setting to reverse the pan movement. Default is OFF. Setting to reverse the tilt movement. Default is OFF.	
		Feedback ON or OFF Hibernation OFF / 1 to 99 Minutes	Pan & Tilt motor position feedback. Default is ON. Sets standby mode. Default is 15 minutes.	
		Service Setting	Password XXX	Password for RDM PID editing. Password is "050"
			RDM PID XXXXXX	Displays RDM PID Code.
	Fans Control	Auto High	This setting sets the fans speed. Default is Auto.	
	Display Setting	Shutoff Time 2 to 60 minutes	Sets the amount of time the LCD display will stay on after last button press. Default is 5 minutes.	
		Display Reverse AUTO / ON / OFF	This menu option flips the LCD Display 180 degrees. Default is AUTO (automatic flips according to luminaire orientation).	
		Key Lock ON or OFF	This option can be set to prevent unauthorized changes (locks display). Default is OFF.	
	Temperature C/F	Celsius or Fahrenheit	Displays temperature values in the set scale. Default is Celsius.	
	Initial Status	Control =XXX	Selection and manual adjustment of fixture parameters for initial power up preset.	
Select Signal	DMX Only / Art-Net On IP2 / Art-Net On IP10	Selects the control system the luminaire will operate. Default is DMX Only.		
Set Universe	000~255	Sets the Art-Net Universe.		
Reset Default	ON or OFF	Restores the fixture to factory defaults. Default is OFF.		
Reset Function	Reset All		Resets (re-calibrates) all motors in the luminaire.	
	Reset Pan&Tilt		Resets (re-calibrates) Pan and Tilt.	
	Reset CMY&Colors		Resets (re-calibrates) CMY wheels and color wheels.	
	Reset Gobos		Resets (re-calibrates) gobos.	
	Blade Reset		Resets (re-calibrates) Blade.	
	Reset Others		Resets (re-calibrates) Zoom, Prism, Frost and Focus.	
Effect Adjust	Test Channel	Control = XXX	Manual selection of fixture parameters for ramping up and down.	
	Manual Control	Control = XXX	Select and adjust fixture parameters for local control.	
	Calibration	Calibrate Password	Password is "050"	
		Pan=XXX	Sets centre points for parameter ranges.	



## DMX CONTROL

This section contains information for operating the luminaire using DMX control.

**Note:** This table assumes a DMX start address of 1. When a different starting address is used, this address becomes channel 1 function and other functions follow in sequence.

### SL LEDSPOT 300 Luminaire DMX Mapping

Table 5 provides DMX channel mapping of all DMX512 control values for the SL LEDSPOT 300 Luminaire.

Table 5: SL LEDSPOT 300 Luminaire DMX Channel Mapping

DMX	Parameter	Range DMX	Range %	Defaults*	Description	Notes
1 2	Pan High Pan Low	0-65535	0-100%	32767	Fixture Pan -	
3 4	Tilt High Tilt Low	0-65535	0-100%	32767	Fixture Tilt -	
5 6	Intensity High Intensity Low	0-65535	0-100%	0	16 Bit Dimming	
7	Shutter / Strobe	0-255	0-100%	0	0-31 Closed 32-63 Open 64-95 Strobe Slow to Fast 96-127 Open 128-159 Pulse 160-191 Open 192-223 Random Strobe Slow to fast 224 - 255 Shutter Open	
8	Color Wheel	0-255	0-100%		0-15 Open 16-25 Color 1 26-35 Color 2 36-45 Color 3 46-55 Color 4 56-65 Color 5 66-75 Color 6 76-85 Color 7 86-95 Open 96-105 open + Color 1 Split 106-115 Color 1 + Color 2 Split 116 - 125 Color 2 + Color 3 Split 126 - 135 Color 3 + Color 4 Split 136 - 145 Color 4 + Color 5 Split 146 - 155 Color 5 + Color 6 Split 156 - 165 Color 6 + Color 7 Split 166 - 175 Color 7 + open Split 176 - 185 open 186 - 216 Scroll Clockwise fast to	

					slow 217 - 247 Scroll counter Clockwise slow to fast 248 - 255 Open	
9 10	Cyan Color Flag High Cyan Color Flag Low	0-65535	0-100%	0	16 Bit Color Control	
11 12	Magenta Color Flag High Magenta Color Flag Low	0-65535	0-100%	0	16 Bit Color Control	
13 14	Yellow Color Flag High Yellow Color Flag Low	0-65535	0-100%	0	16 Bit Color Control	
15	CTO Color Flag	0-65535	0-100%	0	0 - 50 open 51-100 CTO on 101 - 255 reserved for use - Open	
16 17	Zoom High Zoom Low	0-65535	0-100%	3840	16 Bit Zoom control	
18 19	Focus High Focus Low	0-65535	0-100%	29440	16 Bit Focus Control	Default should be fixture in focus as open spot in default zoom @6m distance
20	Gobo Wheel 1 (Rotating Gobo Wheel)	0-255	0-100%	0	0-5 Open 6 - 10 Gobo 1 Circles of Holes Index 11 - 15 Gobo 2 Blades Index 16 - 20 Gobo 3 Punch Card Index 21 - 25 Gobo 4 Sliced Index 26 - 30 Gobo 5 Wavy Triangle Index 31 - 35 Gobo 6 Spiral Index 36 - 40 Open 41 - 45 Gobo 1 Circle of Holes Rotation 46 - 50 Gobo 2 Blades Rotation 51 - 55 Gobo 3 Punch Card Rotation	

					<p>56 - 60 Gobo 4 Sliced Rotation</p> <p>61 - 65 Gobo 5 Wavy Triangle Rotation</p> <p>66 - 70 Gobo 6 Spiral Rotation</p> <p>71 - 85 Open</p> <p>86 - 90 Circle of Holes Shake (Rotation available as well) Fast to Slow</p> <p>91 - 95 Blades (Rotation available as well) Fast to Slow</p> <p>96 - 100 Punch Card Shake (Rotation available as well) Fast to Slow</p> <p>101 - 105 Sliced Shake (Rotation available as well) Fast to Slow</p> <p>106 - 110 Wavy Triangle Shake (Rotation available as well) Fast to Slow</p> <p>111 - 115 Spiral Shake (Rotation available as well) Fast to Slow</p> <p>116 -120 Open</p> <p>121 - 180 Gobo Wheel Scroll fast to slow clockwise</p> <p>181 - 185 Open</p> <p>186 - 246 Gobo Wheel Scroll slow to fast counter clockwise</p> <p>247 - 255 Open</p>	
21	Gobo Wheel 1 Index / Rotation High				0-32756 Fast to Slow rotation / Index Counter Clockwise direction	
22	Gobo Wheel 1 Index Rotation Low	0-65535	0-100%	32767	<p>32757 - 32780 Home (Stop)</p> <p>32781 - 65535 Forwards gobo rotation from slow to fast</p>	
23	Gobo Wheel 2 (Fixed Gobo Wheel)	0-255	0-100%	0	<p>0-10 Open</p> <p>11-20 Gobo 1 Night Sky</p> <p>21-30 Gobo 2 Leafy Breakup</p> <p>31-40 Gobo 3 Swirl</p> <p>41-50 Gobo 4 Lattice</p> <p>51-60 Gobo 5 Bricked Out</p> <p>61-70 Gobo 6 Tribal</p> <p>71-80 Gobo 7 Alpha Rays</p> <p>81-90 Gobo 8 Grid</p>	

					<p>91-100 Gobo 9 Honeycomb</p> <p>101-110 OPEN</p> <p>111-120 Gobo 1 Night Sky Slow to fast</p> <p>121-130 Gobo 2 Leafy Breakup Shake Slow to fast</p> <p>131-140 Gobo 3 Swirl Shake Slow to fast</p> <p>141-150 Gobo 4 Lattice Shake Slow to fast</p> <p>151-160 Gobo 5 Bricked Out Shake Slow to fast</p> <p>161-170 Gobo 6 Tribal Shake Slow to fast</p> <p>171-180 Gobo 7 Alpha Rays Shake Slow to fast</p> <p>181-190 Gobo 8 Grid Shake Slow to fast</p> <p>191-200 Gobo 9 Honeycomb Slow to fast</p> <p>201-215 Open</p> <p>216-230 Gobo Wheel Scroll fast to slow clockwise</p> <p>231-235 Open</p> <p>236-250 Gobo wheel scroll slow to fast</p> <p>251-255 Open</p>	
24	Prism	0-255	0-100%	0	<p>0-30 Open</p> <p>31-60 Prism Index</p> <p>61-90 Open</p> <p>91-120 Prism Rotation</p> <p>121-150 Open</p> <p>151-255 Future use</p>	
25	Prism Index/Rotation High	0-65535	0-100%	32767	0-32756 Fast to Slow rotation / Index Counter Clockwise direction	
26	Prism Index/Rotation Low				32757 - 32780 Home (Stop)	32781 - 65535 Forwards prism rotation from slow to fast
27	Frost	0-255	0-100%	0	0-50 Open	

					51-100 Frost 100-150 Open 151-255 Future use	
28	Iris	0-255	0-100%	0	0-200 Max. diameter to Min.diameter 201 - 255 Iris Pulse slow to fast	
29	Blade 1 A Insert High	0-65535	0-100%	0	0-65535 blade out or beam to blade full inserted into beam	
30	Blade 1 A insert Low					
31	Blade 1 B Insert High					
32	Blade 1 B Insert Low					
33	Blade 2 A Insert High	0-65535	0-100%	0	0-65535 blade out or beam to blade full inserted into beam	
34	Blade 2 A insert Low					
35	Blade 2 B Insert High					
36	Blade 2 B Insert Low					
37	Blade 3 A Insert High	0-65535	0-100%	0	0-65535 blade out or beam to blade full inserted into beam	
38	Blade 3 A insert Low					
39	Blade 3 B Insert High					
40	Blade 3 B Insert Low					
41	Blade 4 A Insert High	0-65535	0-100%	0	0-65535 blade out or beam to blade full inserted into beam	
42	Blade 4 A insert Low					
43	Blade 4 B Insert High					
44	Blade 4 B Insert Low					
45	Blade Gate Rotation High	0-65535	0-100%	32767	0-32756 angle - from 0°  32757 - 32780 Home 0°  32781 - 65535 angle + from 0°	
46	Blade Gate Rotation Low					
47	Blade Macro effects					

					<p>31-45 Macro 2            46-60 Macro 3            61-75 Macro 4            76-90 Macro 5            91-105 Macro 6            106-120 Macro 7            121-135 Macro 8            136-150 Macro 9            151-165 Macros 10            166-180 Macro 11            181-195 Macro 12            196-210-Macro 13            211-225 Macro 14            226-240 Macro 15            241 - 255 Macro 16</p>	
48	Blade speed / timing	0-255	0-100%	0	<p>0 - 20 Blade at most accurate fast speed            21 - 255 Blade movement fast to slow</p>	
49	Movement Speed / Timing	0-255	0-100%	0	<p>0-20 <u>Smoothest</u> movement all fixtures match &amp; accurate            21-255 Movement speed fast to slow</p>	
50	Auto Focus	0-255	0-100%	0	<p>Auto Focus Off = 0 - 50            Auto Focus On = 51-150 7.5m throw distance            Auto Focus On = 51-150 15m throw distance</p>	
51	CMY Speed / Timing	0-255	0-100%	0	<p>0-20 <u>smoothest</u> color movement all fixtures match &amp; accurate            21-255 color Movement speed fast to slow</p>	
52	Dimmer Mode	0-255	0-100%	0	<p>0-40 Standard Dimming            41-80 Stage Dimming curve            81-120 TV Dimming curve            121-160 Architectural Dimming curve            161-200 Theatre Dimmer curve            201-255 For future use</p>	
53	Control Channel	0-255	0-100%	0	<p>0-39 Idle            40-59 No Function            60-79 No Function</p>	To execute a command, the control

				80-84 Full Reset 85-87 Pan / Tilt reset 88-90 Color reset 91-93 Gobo Reset 94-96 Blade Iris reset 97-99 Prism & Frost Other motor reset 100-119 Internal Program 1 120-139 Internal Program 2 140-159 Internal Program 3 160-179 Internal Program 4 180-199 Internal Program 5 200-219 Internal Program 6 220-239 Internal Program 7  240-255 Reserved	channel must be set to idle (DMX 0) then changed to a particular value and held for 3 seconds then restored to DMX 0. Upon completion of this routine, the desired command will be executed by the luminaire.
--	--	--	--	--------------------------------------------------------------------------------------------------------------------------------------------------------------------------------------------------------------------------------------------------------------------------------------------------------------------------------------------------------------------------------------------------	---------------------------------------------------------------------------------------------------------------------------------------------------------------------------------------------------------------

## Product Specifications

### Features

#### Color System

One fixed color wheel with 7 colors and one open slot. Color system allows for split color mode and color scroll effects.

#### Gobos / Effects

One fixed gobo / Static gobo wheel with 9 indexing gobos plus open. Optional gobo shaking mode.

One rotating gobo / Rotation gobo wheel with 6 interchangeable and indexing gobos plus open. Optional gobo shaking mode.

#### Prisms

One (3) facet linear prism.

#### Zoom:

10°~45° linear zoom

#### Power Consumption

450 Watts



## Movement

Pan 540°

Tilt 255°

## Safety distance

Minimum hang distance between fixture centers is 600mm

## Weight

Net weight: 28 kg / 61.73 lbs

Gross weight: 34 kg / 74.96 lbs

## AC Power Input

100 to 240 VAC

---

**Note:** Information contained herein is subject to change without prior notice. Refer to the current luminaire specification sheet for complete and up-to date information.

---

# Luminaire Dimensions

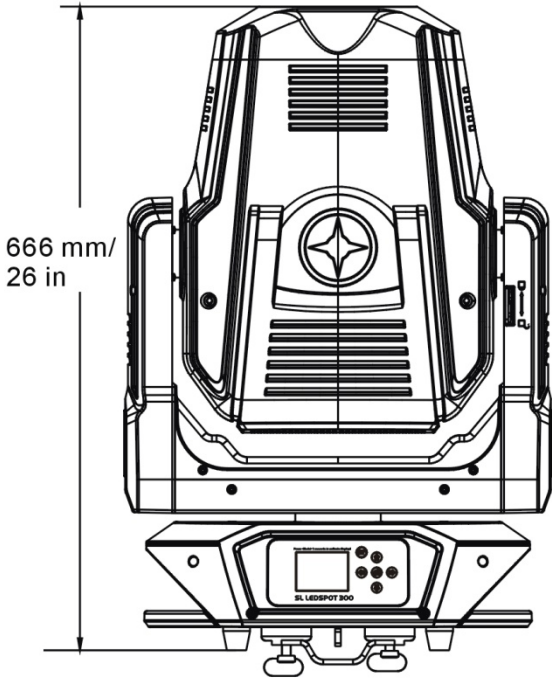
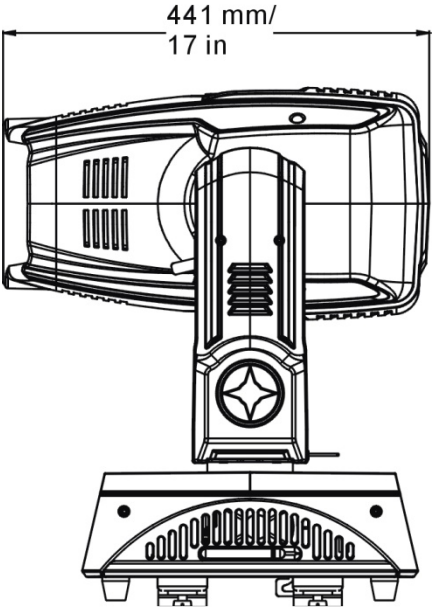
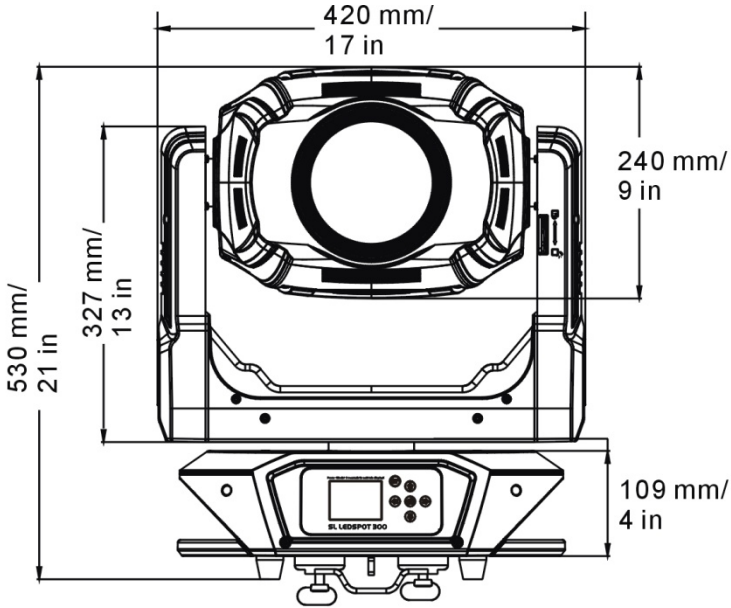





# Showline

## Dallas

10911 Petal Street

Dallas, TX 75238

Tel : +1214- 647- 7880

Fax: +1214- 647- 8031

## Asia

Unit C, 14/ F, Roxy Industrial Centre

No. 41- 49 Kwai Cheong Road

Kwai Chung, N. T , Hong Kong

Tel : +852 2796 9786

Fax: +852 2798 6545

## Auckland

19- 21 Kawana Street

Northcote, Auckland 0627

New Zealand

Tel : +64 9 481 0100

Fax: +64 9 481 0101

## Europe

Rondwegzuid 85

Winterswijk 7012 JD

The Netherlands

Tel : +31 ( 0) 543- 542516

©2016 Philips Group.

