

Date: Combined with light effect:

Firm name:

Project:

Product description

Luminous patterns are customizable and built-to-order sheet metal surface mounted panels with integrated patterns of dynamic LED light. The panels can be specified in one of five different light effects: Round sparkling, Linear sparkling, 2D graphic, 3D graphic and Brilliant graphic. Empty panels are also available.

The panels are available in various Akzonobel powder coat finishes or 3M DI-NOC/Greenfilm foils, of which various finishes can be overlaid with printed graphics.



Dimensions

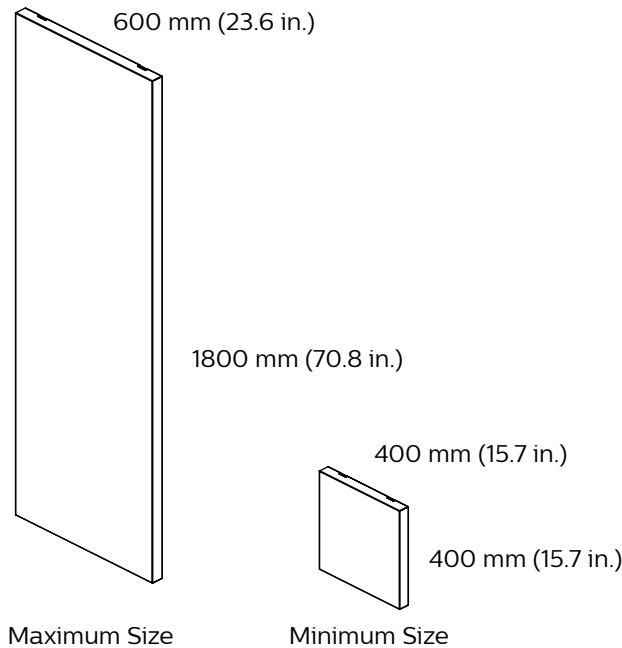

Mounting details

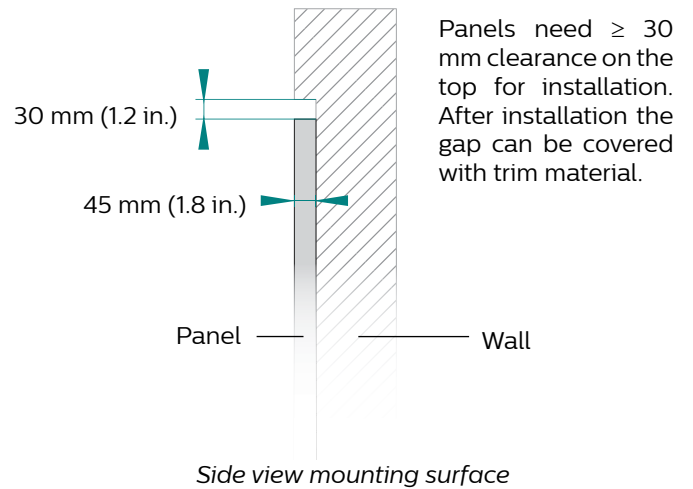

Shapes

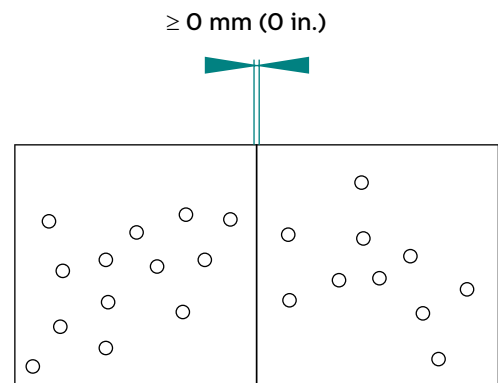
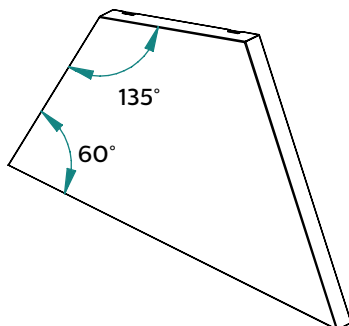

Panels are individually mounted with panel gaps of 0 mm or more

All quadrangular shapes with a minimum corner angle of 60° and a maximum corner angle of 135°

Specification table

Product		Empty Panel
Item	Specification	Details
Physical	Panel Length & Height Dimensions	Min. 400 mm x 400 mm (15.75 in. x 15.75 in.) Max. 1800 mm x 600 mm (70.87 in. x 23.62 in.)
	Panel Corner Angles	Min. panel corner angle 60° Max. panel corner angle 135°
	Panel Thickness	45 mm (1.77 in.)
	Panel Material	0.8 mm steel
	Finish options	Akzonobel Interpon Metallic D1036 Matt Collection (+ UV printing*) Akzonobel Interpon D2525 Collection Anodic (+ UV printing*) Akzonobel Interpon Collection Futura 2014-2017 (+ UV printing*) Akzonobel Interpon D1036 RAL Color Collection (+ UV printing*) 3M DI-NOC Architectural Foils (+ UV printing*) 3M IJ3545C GreenFilm (PVC free) + 3M 8909 Green Overlamine + printing
	Mounting Surface Material	Wood; when mounting panels on other materials a wooden frame should be mounted
	Mounting Type	Surface mounted, recessed on walls & ceilings
	Humidity	0 - 95%, non-condensing
	Temperature Ranges	15° - 40° C (59° - 104 F) Operating -20 °C - 50 °C (-4° - 122 F) Storage
	Weight Empty Panel (No Electronics Inside)	400 mm x 400 mm 15.75 in. x 15.75 in. 2.9 kg (6.4 lbs) 600 mm x 1800 mm 70.87 in. x 23.62 in. 14.4 kg (31.7 lbs)
Certification and Safety	Certification	CE, UL / cUL **
	Fire-Classification	B - s2, d0
	Environment	Dry indoor location IP40

* UV printing available on a range of finishes

** UL/cUL and Fire-Classification not valid in combination with 3M DI-NOC Architectural Foils or 3M Greenfilm + Overlamine

Ordering information

To order a Luminous patterns installation please contact us at:

luminouspatterns@philips.com



© 2017 Philips Lighting Netherlands
All rights reserved

Specifications are subject to change without notice.

<http://www.luminouspatterns.com/>

Date:
Firm name:
Project:

Light effect description

The Round sparkling light effect is a custom Ø30 mm (1.2 in.) light node that creates a sparkling effect similar to a votive candle. Each Round sparkling light node houses an individually addressable single LED, available in 2200k warm white or color changing RGB. Custom color temperatures are available on request.



Dimensions

Typical Installation

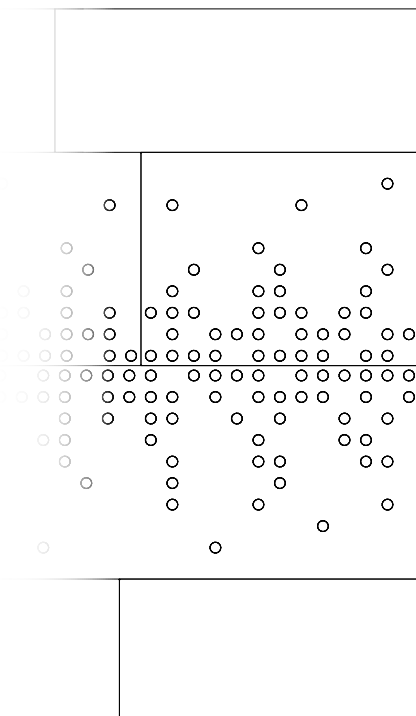

Front view

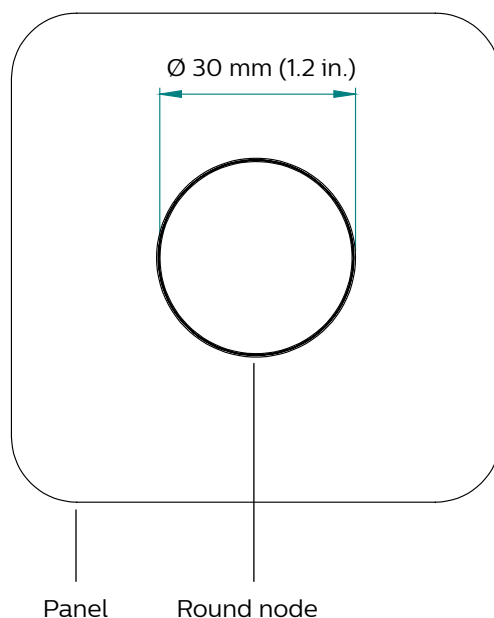

1.8 - 1.2 mm (0.07 - 0.05 in.)

Side view

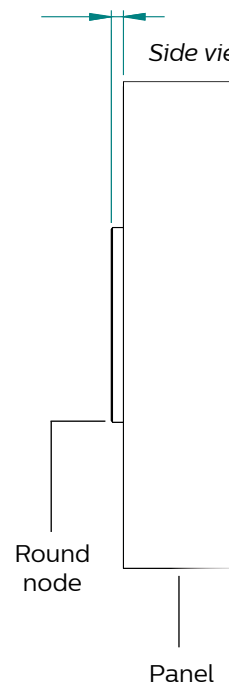

Specification table

Product		Round sparkling white	Round sparkling RGB	
Item	Specification	Details		
Output	Color Temperature	2200 k	N/A	
	LED Channels	White	Red Green Blue	
Electrical	Input Voltage	7.5 VDC via sPDS-480ca and PDS-60ca		
	Maximum Power Consumption Per Node	0.5 W		
Control	Interface	sPDS-480ca 7.5V (Ethernet) PDS-60ca 7.5V (Pre-programmed or DMX / Ethernet)		
	Control System	Philips full range of controllers, including Video System Manager Pro, Light System Manager, and iPlayer 3, or third-party controllers		
Physical	Node Size	ø30 mm (1.2 in.)		
	Node Material	Polycarbonate* or Glass		
	Node Height From Panel	2 mm (0.08 in.)		
	Max. Node Count Per Panel	72		
	Max. Node Count Per Power / Data Supply	sPDS-480ca 7.5V: 1152 nodes PDS-60ca 7.5V: 144 nodes		
	Weight Base Panel With 1 Node	400 mm x 400 mm (15.75 in. x 15.75 in.)	3.2 kg (7.1 lbs)	
		600 mm x 1800 mm (70.87 in. x 23.62 in.)	14.7 kg (32.4 lbs)	
	Added Weight Per Extra Node	0.06 kg (0.13 lbs)		
Certification	Fire-classification	On request		

* Limits the maximum installation size to 360 x 240 cm.

Ordering information

To order a Luminous patterns installation please contact us at:

luminouspatterns@philips.com



© 2017 Philips Lighting Netherlands
All rights reserved

Specifications are subject to change without notice.

<http://www.luminouspatterns.com/>

Date:
Firm name:
Project:

Light effect description

The Linear sparkling light effect consists of custom light nodes that come in lengths of 75 mm (3 in.), 200 mm (7.9 in.) or 300 mm (11.8 in.).

Linear sparkling light nodes create a sparkling line of light in resemblance of the old linear incandescent Edison bulbs. The 200 mm (7.9 in.) and 300 mm (11.8 in.) Linear sparkling light nodes house two individually addressable LEDs at each end. This allows for sweeping light shows and unique 'in-line' color mixing. The 75 mm (3 in.) Linear sparkling light nodes houses one individually addressable LED.

Linear sparkling light node LEDs are available in 2200k warm white or color changing RGB. Custom color temperatures are available on request.

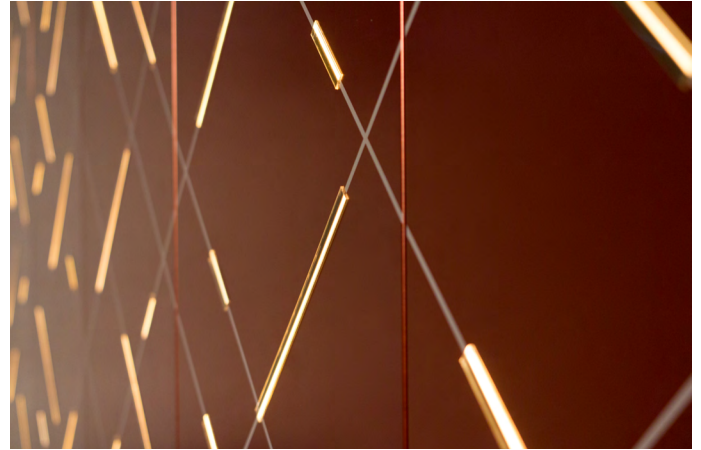

Dimensions

Typical Installation

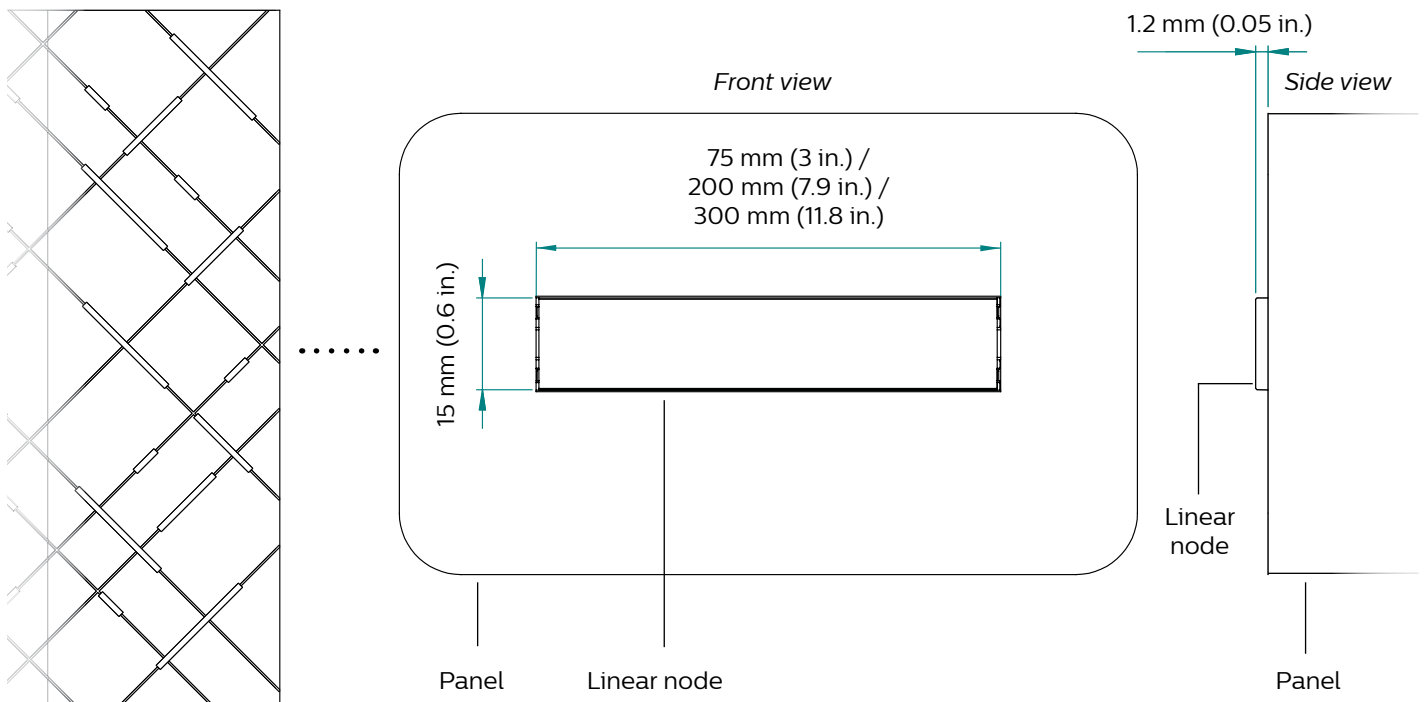

Specification table

Product		Linear sparkling white	Linear sparkling RGB	
Item	Specification	Details		
Output	Color Temperature	2200 k	N/A	
	LED Channels	White	Red, Green, Blue	
Electrical	Input Voltage	7.5 VDC via sPDS-480ca, and PDS-60ca		
	Maximum Power Consumption Per Node PCBA	0.7 W	0.7 W	
Control	Interface	sPDS-480ca 7.5V (Ethernet) PDS-60ca 7.5V (Pre-programmed or DMX / Ethernet)		
	Control System	Philips full range of controllers, including Video System Manager Pro, Light System Manager, and iPlayer 3, or third-party controllers		
Physical	Node Sizes	15 mm (0.6 in.) x 75 mm (3 in.), 200 mm (7.9 in.) or 300 mm (11.8 in.).		
	Node Material	PMMA *		
	Node Height From Panel	2 mm (0.08 in.)		
	Max. Node Count Per Panel	75 mm (3 in.)	72	
		200 mm (7.9 in.)	36	
		300 mm (11.8 in.)	36	
	Max. Node Count Per Power / Data Supply	75 mm (3 in.)	sPDS-480ca 7.5V: 1152 nodes PDS-60ca 7.5V: 144 nodes	
		200 mm (7.9 in.)	sPDS-480ca 7.5V: 576 nodes PDS-60ca 7.5V: 72 nodes	
		300 mm (11.8 in.)	sPDS-480ca 7.5V: 576 nodes PDS-60ca 7.5V: 72 nodes	
	Weight Base Panel With 1 Node	400 mm x 400 mm (15.75 in. x 15.75 in.)	3.3 kg (7.3 lbs)	
600 mm x 1800 mm (70.87 in. x 23.62 in.)		14.8 kg (32.6 lbs)		
Added Weight Per Extra Node	75 mm (3 in.)	0.07 kg (0.15 lbs)		
	200 mm (7.9 in.)	0.1 kg (0.22 lbs)		
	300 mm (11.8 in.)	0.13 kg (0.29 lbs)		

* Limits the maximum installation size to 360 x 240 cm.

Ordering information

To order a Luminous patterns installation please contact us at:

luminouspatterns@philips.com



© 2017 Philips Lighting Netherlands
All rights reserved

Specifications are subject to change without notice.

<http://www.luminouspatterns.com/>

Date:
Firm name:
Project:

Light effect description

2D graphic

The 2D graphic light effect is a backlit 2D cut-out, powered by custom 115 mm x 115 mm (4.5 in. x 4.5 in.) light modules. These light modules can be freely placed and come in 2700k warm white or color changing RGB. Custom color temperatures are available on request.



3D graphic

The 3D graphic light effect is a backlit cut-out bend outwards to create a 3-dimensional effect. These 3D cut-outs are powered by custom 115 mm x 115 mm (4.5 in. x 4.5 in.) light modules, available in 2700k warm white or color changing RGB. Custom color temperatures are available on request.

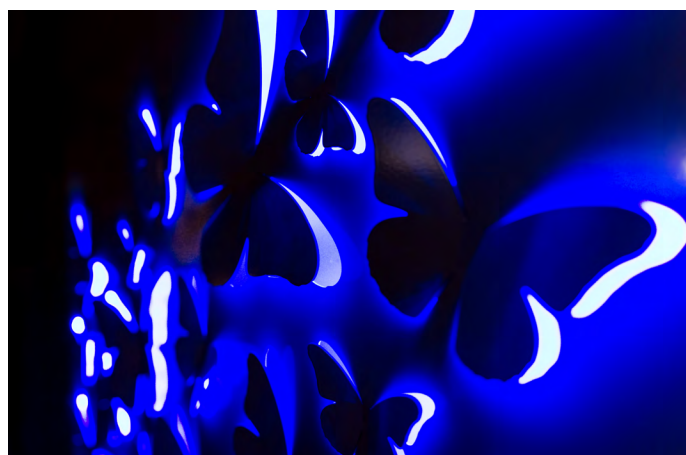

Dimensions

Typical Installation

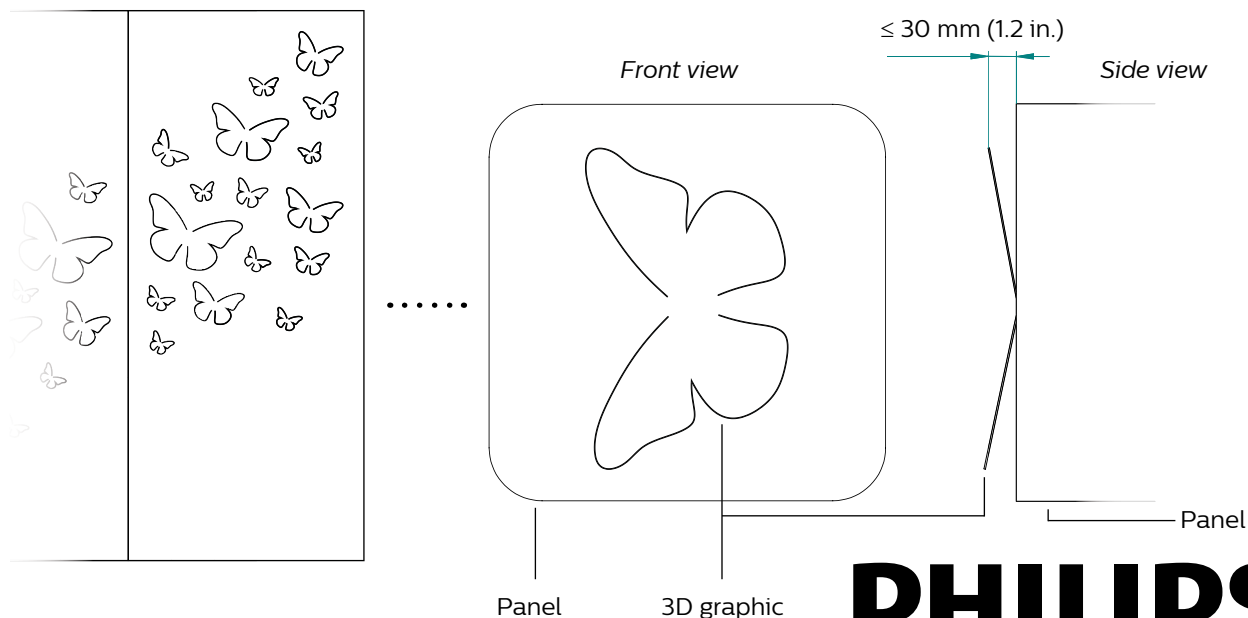

Specification table

Product		2D & 3D graphic white	2D & 3D graphic RGB	
Item	Specification			
Output	Color Temperature	2700 k	N/A	
	LED Channels	White	Red Green Blue	
Electrical	Input Voltage	24 VDC via sPDS-480ca, and PDS-60ca		
	Maximum Power Consumption Per Node	2.8 W	8.3 W	
Control	Interface	sPDS-480ca 27V (Ethernet) PDS-60ca 24V (Pre-programmed or DMX / Ethernet)		
	Control System	Philips full range of controllers, including Video System Manager Pro, Light System Manager, and iPlayer 3, or third-party controllers		
Physical	2D/3D graphic size	Variable		
	Diffuser material	Glass + Diffuser foil		
	Max. Node Count Per Panel	22	40	
	Max. Node Count Per Power / Data Supply	sPDS-480ca 24V: 176 nodes	sPDS-480ca 24V: 56 nodes	
		PDS-60ca 24V: 22 nodes	PDS-60ca 24V: 7 nodes	
	Weight Base Panel With 1 Node (Cut-Out Material Not Taken Into Account)	400 mm x 400 mm (15.75 in. x 15.75 in.)	4.3 kg (9.5 lbs)	
600 mm x 1800 mm (70.87 in. x 23.62 in.)		22.4 kg (49.4 lbs)		
Added Weight Per Extra Node (Cut-Out Material Not Taken Into Account)	0.07 kg (0.15 lbs)			
Certification	Fire-Classification	B - s2, d0		

Ordering information

To order a Luminous patterns installation please contact us at:

luminouspatterns@philips.com



© 2017 Philips Lighting Netherlands
All rights reserved

Specifications are subject to change without notice.

<http://www.luminouspatterns.com/>

Date:
Firm name:
Project:

Light effect description

Brilliant graphic is a unique optical light effect which creates an eye catching sparkle when moving past it. The holes in the surface of the panel can range between 0.6 mm (0.02 in.) and 2 mm (0.08 in.) to create smaller or bigger highlights. The Brilliant graphic light effect is powered by custom 1115 mm x 115 mm (4.5 in. x 4.5 in.) light modules, available in 2700k warm white or color changing RGB. Custom color temperatures are available on request.



Dimensions

Typical Installation

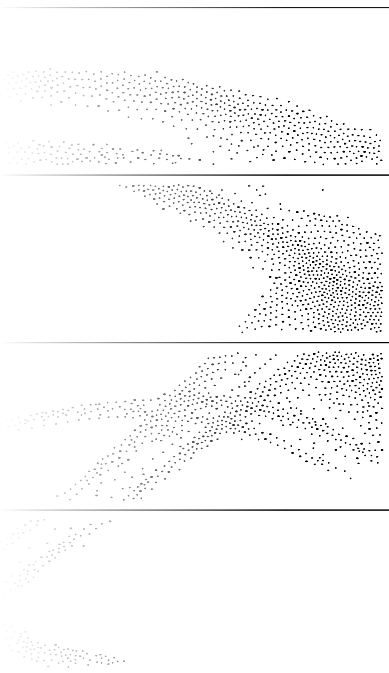

Close-up
Front view

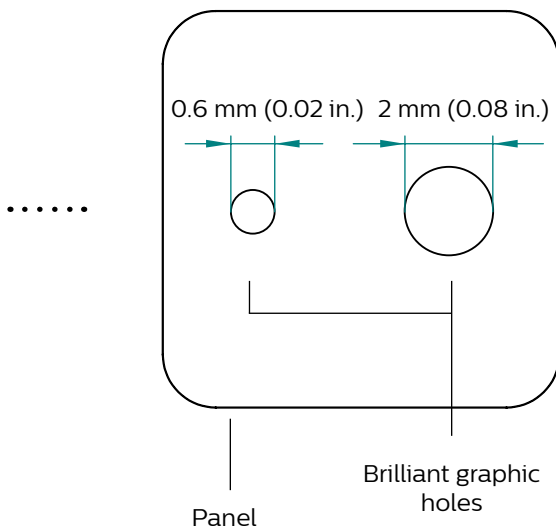

Specification table

Product		Brilliant graphic white	Brilliant graphic RGB	
Item	Specification			
Output	Color Temperature	2700 k	N/A	
	LED Channels	White	Red Green Blue	
Electrical	Input Voltage	24 VDC via sPDS-480ca, and PDS-60ca		
	Maximum Power Consumption Per Node	2.8 W	8.3 W	
Control	Interface	sPDS-480ca 27V (Ethernet) PDS-60ca 24V (Pre-programmed or DMX / Ethernet)		
	Control System	Philips full range of controllers, including Video System Manager Pro, Light System Manager, and iPlayer 3, or third-party controllers		
Physical	Hole sizes	Min 0.6 mm (0.02 in.) - Max. 2 mm (0.08 in.)		
	Lens material	Glass		
	Max. Node Count Per Panel	22	40	
	Max. Node Count Per Power / Data Supply	sPDS-480ca 24V: 176 nodes	sPDS-480ca 24V: 56 nodes	
		PDS-60ca 24V: 22 nodes	PDS-60ca 24V: 7 nodes	
	Weight Base Panel With 1 Node (Cut-Out Material Not Taken Into Account)	400 mm x 400 mm (15.75 in. x 15.75 in.)	3.4 kg (7.5 lbs)	
		600 mm x 1800 mm (70.87 in. x 23.62 in.)	18 kg (39.7 lbs)	
Added Weight Per Extra Node (Cut-Out Material Not Taken Into Account)	0.07 kg (0.15 lbs)			
Certification	Fire-Classification	B - s2, d0 (pending)		

Ordering information

To order a Luminous patterns installation please contact us at:

luminouspatterns@philips.com



© 2017 Philips Lighting Netherlands
All rights reserved

Specifications are subject to change without notice.

<http://www.luminouspatterns.com/>