

Licensing Program for LED- Based Signage

Nathan Millen

Philips Lighting Intellectual Property Organisation

March 24, 2017

Agenda

- Introduction
- Program outline
- Contact info
- Core Technology Examples



This presentation is for information purposes only. It is not intended to be a contract and shall not be legally binding in any respect on any party. There shall be no contract until a final written contract is signed by authorized representatives of both companies.

Business Drivers

- For Licensee
 - Preferred and more economic solutions
 - More flexibility in component sourcing
 - More freedom for optimal solution
- For Licensee and Philips Lighting
 - Accelerate growth of LED Signage markets



LED Signage Systems – What's Involved

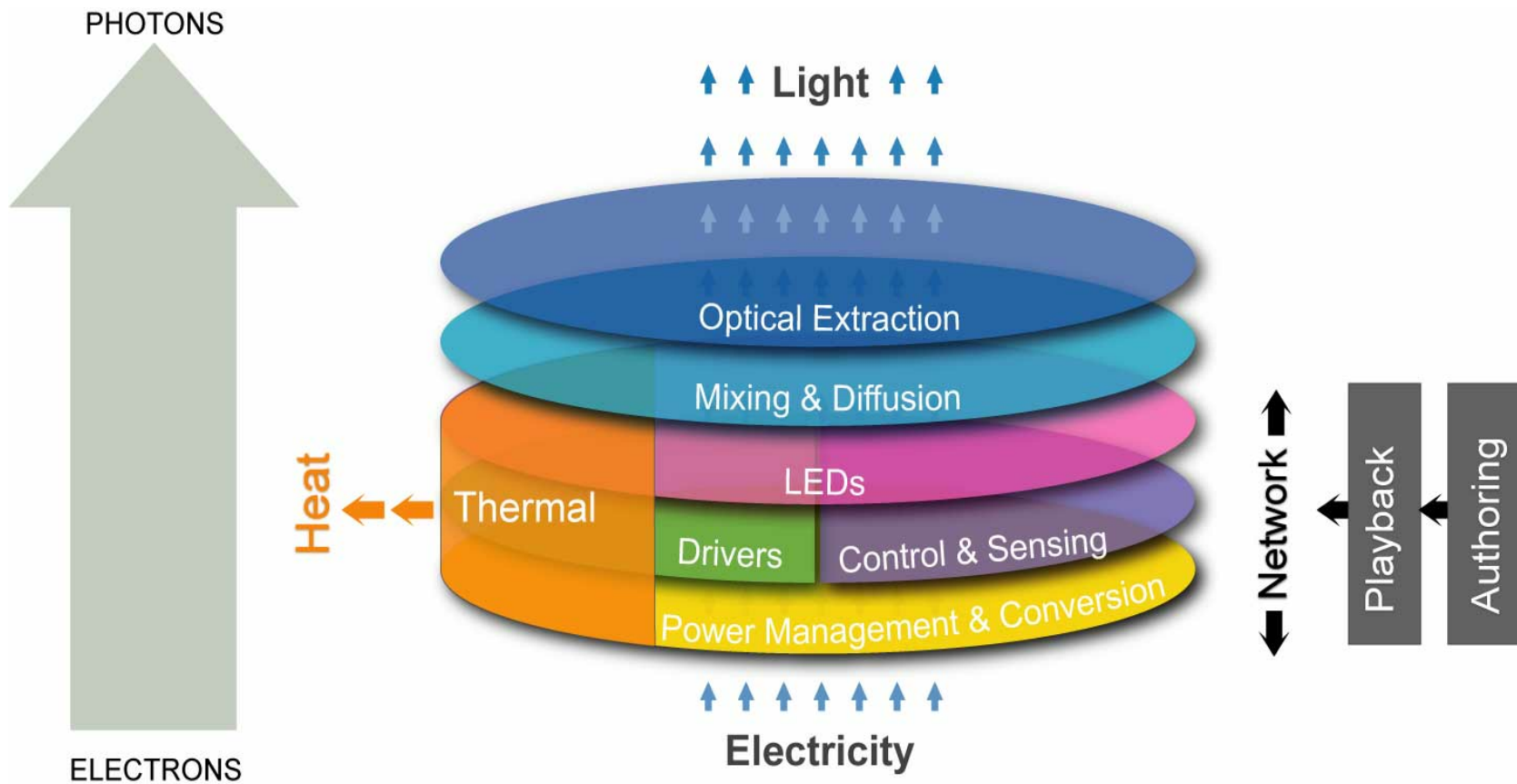

Philips Lighting Licensing Program Outline

- Product scope:
 - Light Engine & Driver (“Signage Kit”)



or -----

- Posterbox
- Field of use
 - LED- Based Signage
- Scope of Licensed patents;
 - Basic LED control and system level technologies
 - Covers IP from Philips and former Color Kinetics and TIR



Licensed Patent Portfolio

- Patents relevant to LED-Based Signage from the open Enabled SSL Licensing Program as well as Signage specific:
- More than 263 patent families
- More than 1802 issued patents
- More than 188 patents pending
- Worldwide
(e.g. US, Europe, China, Japan, Korea, Canada, Australia, Taiwan, Hong Kong)



Expected Relevance

- Creation of LED signage that is homogeneously illuminated
- Light distribution management by creating a Posterbox with LED module(s) within that illuminate at least one wall almost exclusively
- Light distribution management using edge-coupled sheet technologies
- Light distribution in channel letters
- Light distribution in acrylic letters
- Creation of specific color temperature using a combination of phosphor conversion and colored LEDs
- Combination of red, green and blue LEDs to create and tune colored light output
- Sensing and control of LEDs, LED and driver protection, dimming (phase cut, 1-10V), EMI reduction
- Simplified mounting of optics in housing

Royalties for Posterbox & Signage Kit

- **Royalties based on Net Revenues**

- 3% single color (Posterbox)
- 4% Tunable white (Posterbox)
- 5% Color changing (Posterbox)
- or -----
- 9%-kit (Light engine + AC-DC driver)

(Charged only for manufacturing or sales in countries where Philips Lighting has at least one issued patent covering a feature of the licensed product)

- Net Revenue is the price invoiced by a Signage manufacturer or Signage-kit supplier to licensee, excluding freight, insurances, and taxes



Key steps to Agreement



1. Meet with Philips Lighting IP Licensing representative

- One of our licensing specialists will be assigned to your company so you have a personal contact with Philips Lighting. This contact person will explain the Program in detail and answer any questions you may have.

2. Portfolio Analysis

- We work with you to determine which of your products are relevant and require a license (Posterbox- Kit, LED Based Signage)

3. Choose between the **Flat Rate** and **Itemized** approach for the payment of royalties (the fees for use of Philips patented technologies) and conclude the agreement

- In order to protect the confidential information that are exchanged between the parties prior to concluding the license agreement, a mutual, two-sided Non-Disclosure Agreement (NDA) will be signed.

FAQ

- Does this program also include Philips Lighting's designs?
No, the program only relates to patents directed to technology and not to other IP directed to the aesthetic appearance of the products
- I'm interested in applications outside the markets addressed by your program. Can I get a license?
We are willing to further explore your request, but willingness, list of patents and terms can deviate from the program.

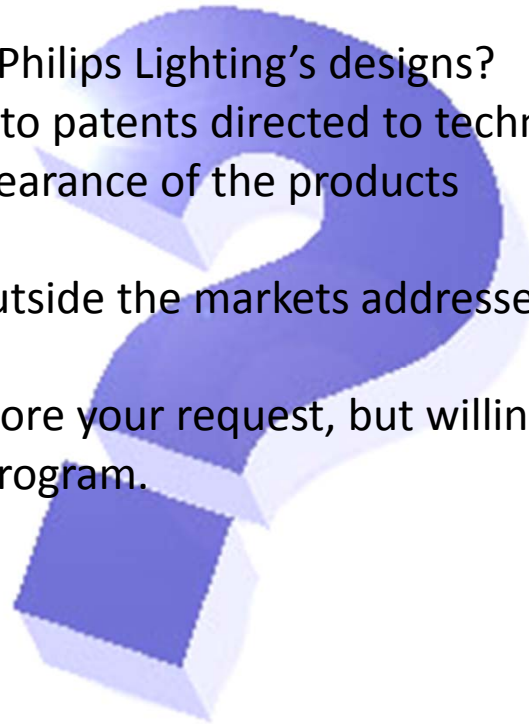

Contact info



: info.SSLicensing@Philips.com



: www.ip.philips.com/licensing/program/112

LED Signage Systems – Examples of what could be involved

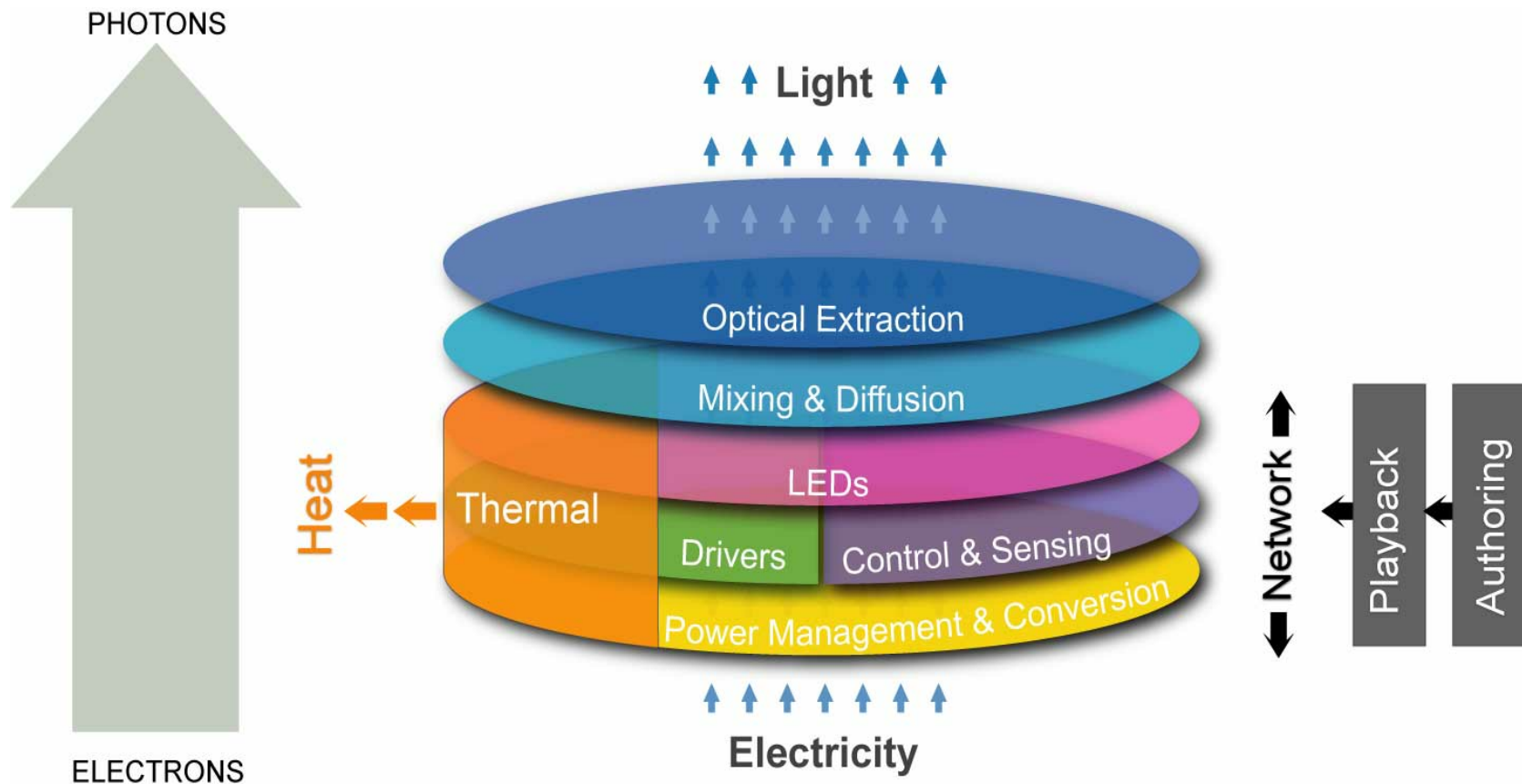

Examples of what could be involved

Core Technologies for LED Signage Systems

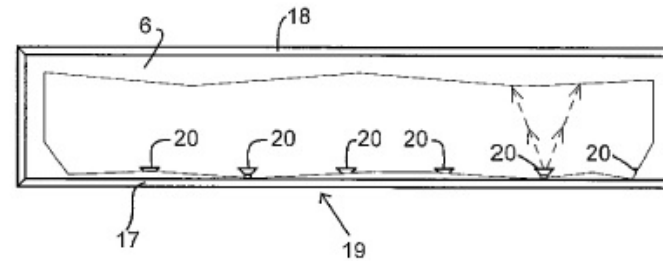
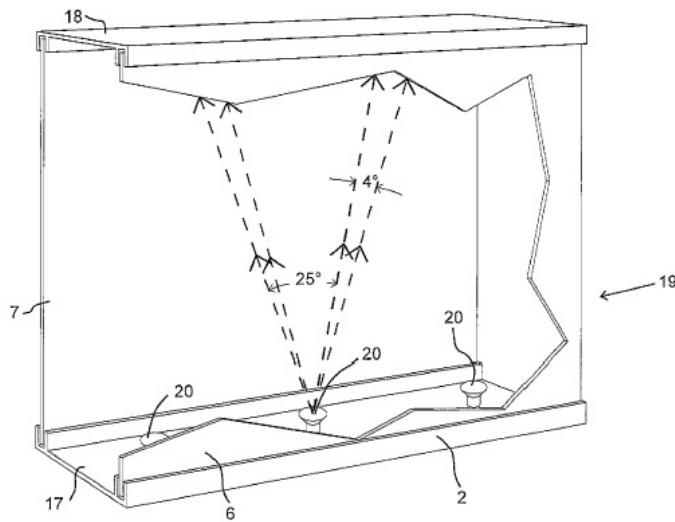

Optical Extraction

Application: Homogeneous illumination of LED Signage Posterboxes

Advantage: Eliminates zoning within a signage display thus improving sign readability and impact

Example Patents/Applications:

North America: US7841733

Europe: EP1938298; EP2390866; EP2779146
 NL1030161; NL2000273;

Asia: CN101300616; JP5390858

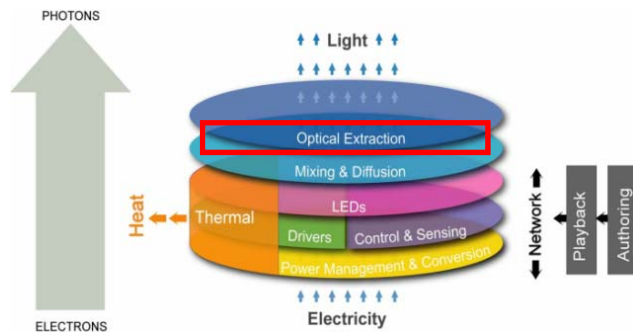

Core Technologies for LED Signage Systems

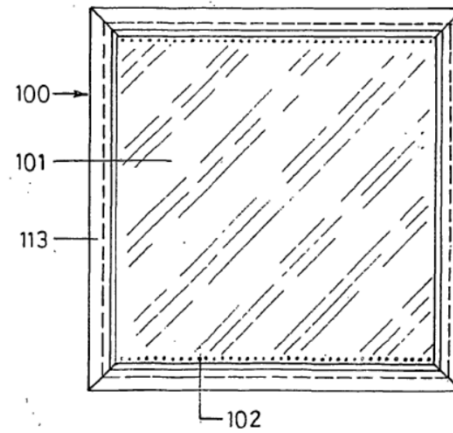
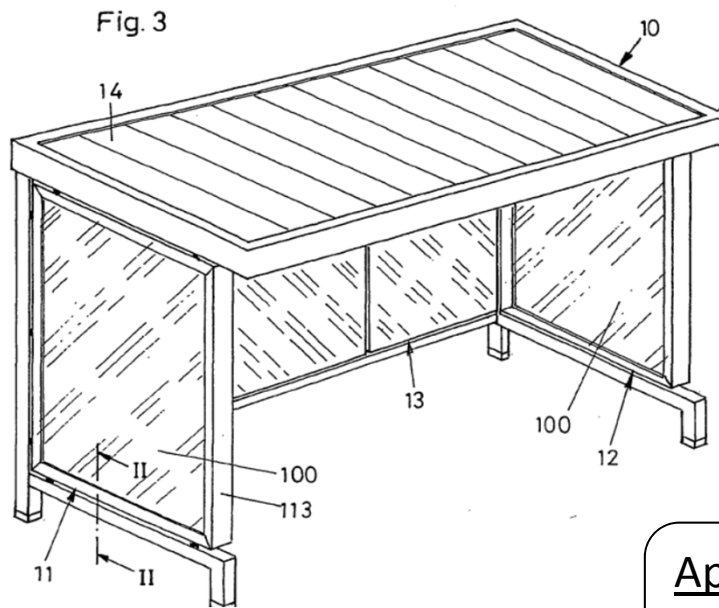

Optical Extraction

Application: Efficient homogeneous illumination of LED Signage displays

Advantage: Provides high light yield for a comparatively low energy consumption

Example Patents/Applications:
Europe: EP1379742

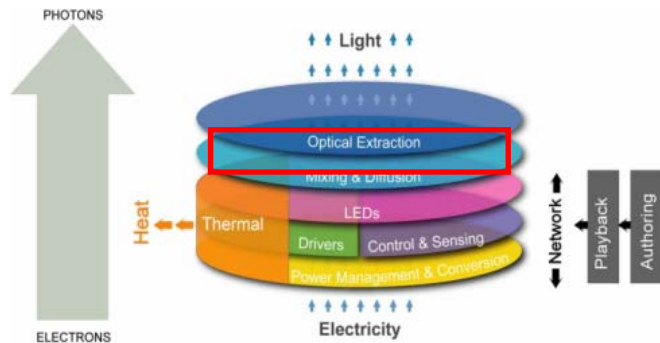

Core Technologies for LED Signage Systems

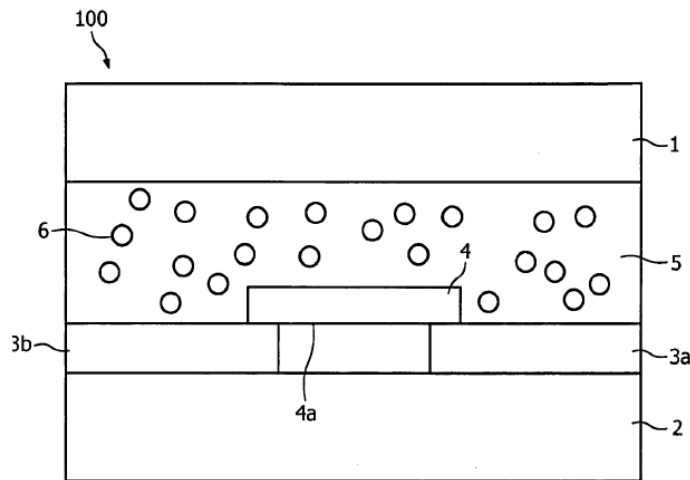

FIG. 1

Optical Extraction

Application: LED at least partly embedded in a translucent layer of a thermoplastic material

Advantage: Increased heat conductivity and reduced bright spots.

Example Patents/Applications:

Europe: EP2190664

US: US8748922

Asia: CN101795860

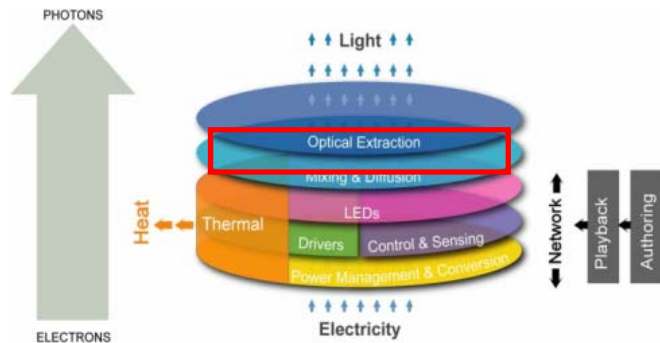

Core Technologies for LED Signage Systems

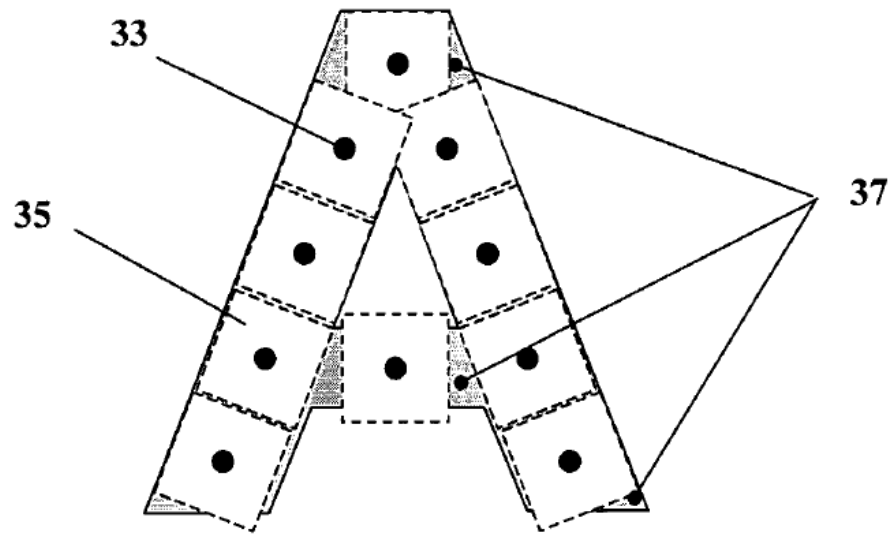
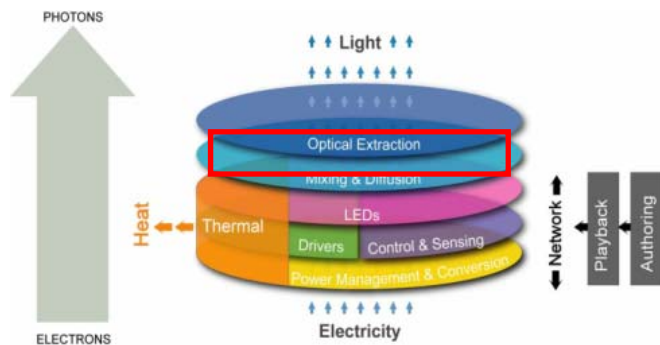

FIGURE 7



Optical Extraction

Application: apparatus for forming an asymmetric illumination beam pattern.

Advantage: Increased homogeneity of illumination of a surface in close proximity to the light sources

Example Patents/Applications:

US: US7652300;
CA2557447

Core Technologies for LED Signage Systems

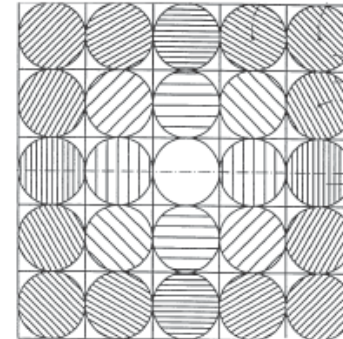
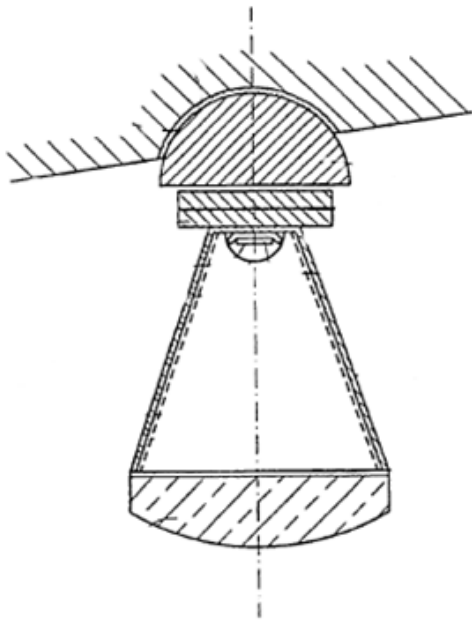

Light Mixing and Diffusion

Application: Light output control

Advantage: Effective and efficient blending and directing of LED light output

Example Patents/Applications:

North America: US6250774; CA2249423

Europe: EP0890059

Asia: JP4014227; TW093750; CN98800051; KR0471705

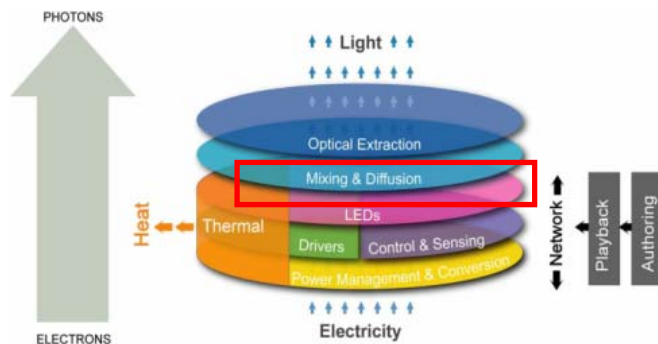

Core Technologies for LED Signage Systems

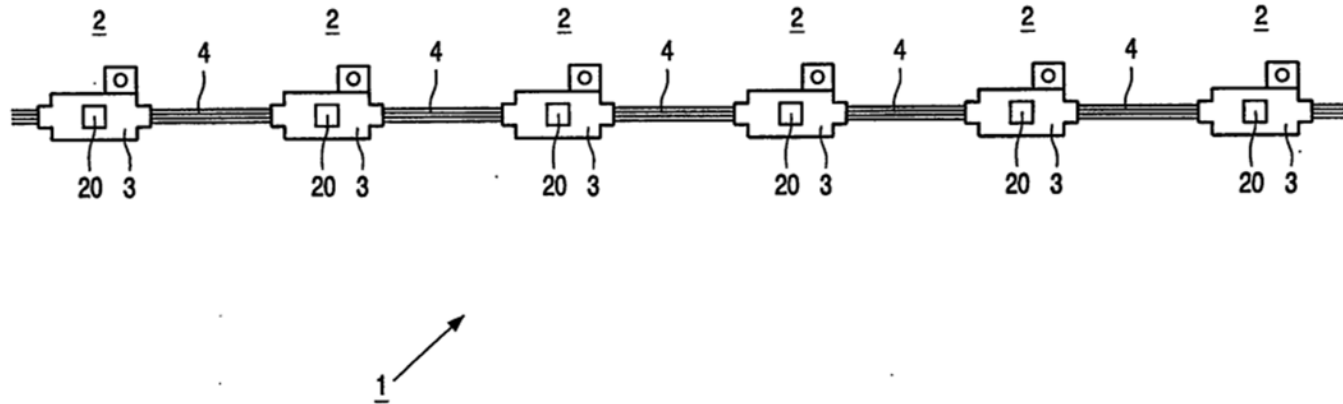

Thermal Management

Application: Thermal management of LED Strings

Advantage: Efficient heat-sinking with simple manufacturing

Example Patents/Applications:

Europe: EP1537354,
Asia: JP4865227

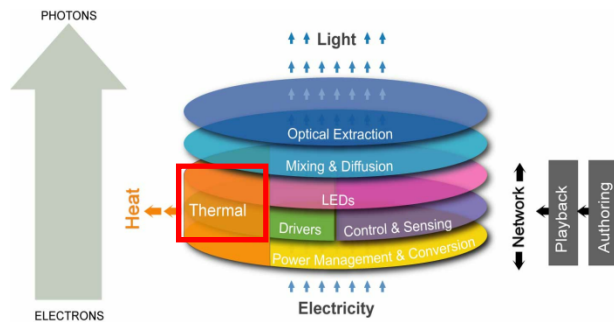

Core Technologies for LED Signage Systems

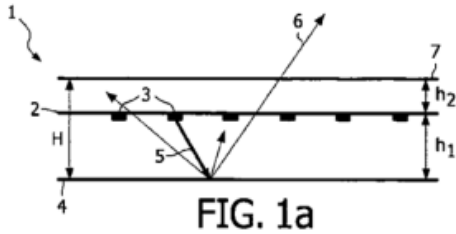

FIG. 1a

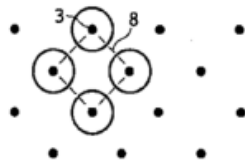

FIG. 1b

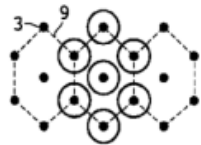

FIG. 1c

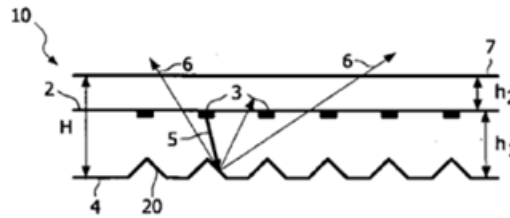

FIG. 2

Light Mixing & Diffusion

Application: Efficient homogeneous illumination of LED Signage displays

Advantage: Provides a thin illumination device using an array of LEDs

Example Patents/Applications:

Europe: EP2082160,
Asia: CN101523109

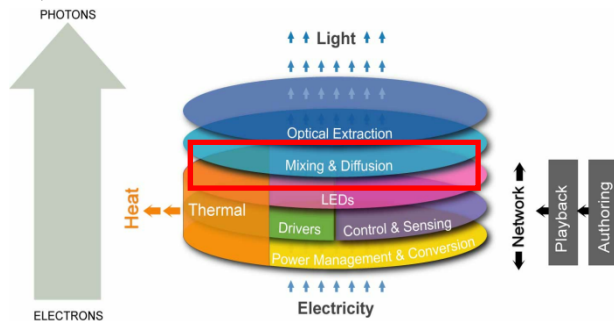

Core Technologies for LED Signage Systems

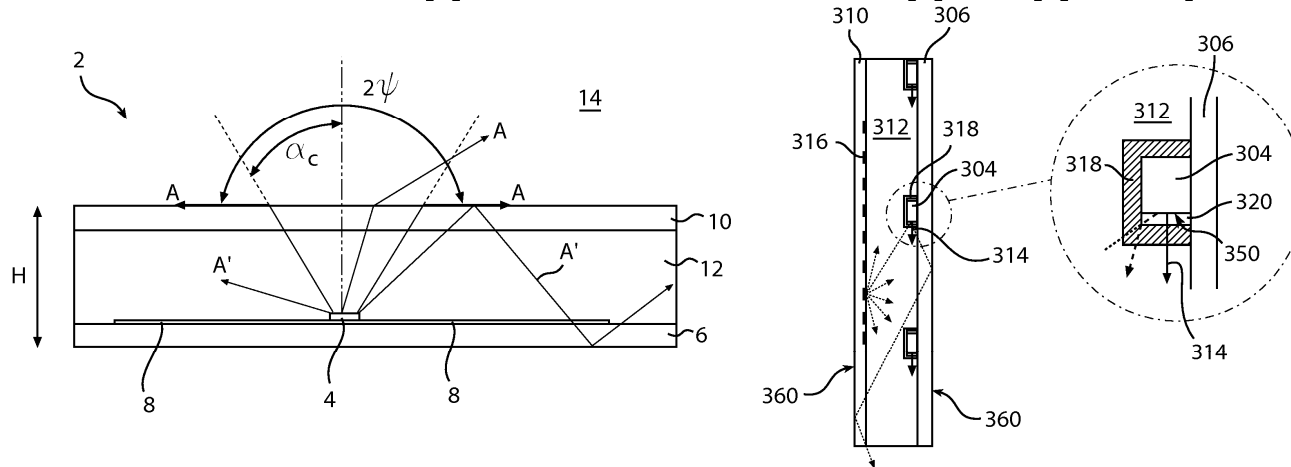

Light Mixing & Diffusion

Application: Efficient homogeneous illumination of LED Signage displays

Advantage: Provides a thin illumination device using side emitting LEDs

Example Patents/Applications:

North America US7943940

Europe: EP2147349,

Asia: JP4955101

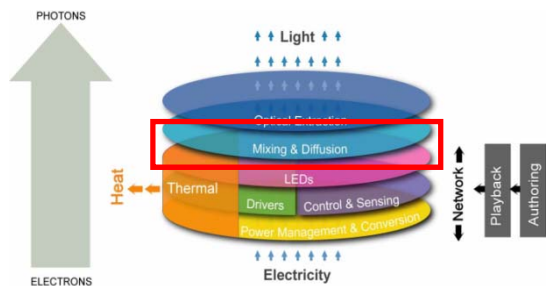

Core Technologies for LED Signage Systems

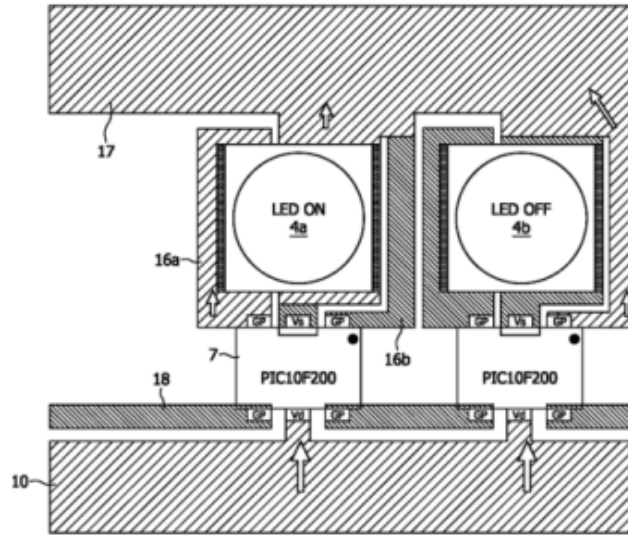
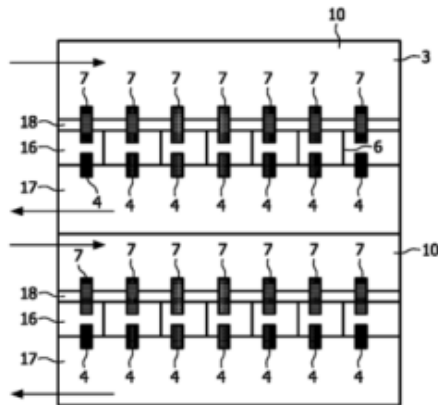

Control and Sensing

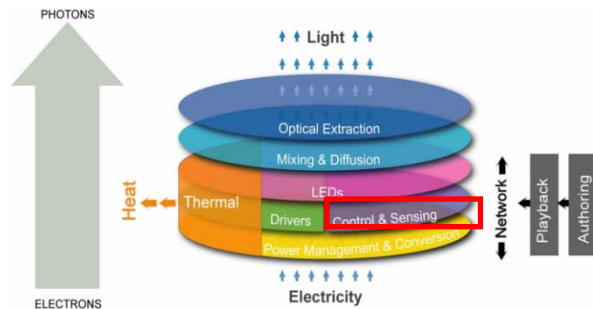

Application: Efficient control of Embedded LEDs

Advantage: Provides a selective control of individual light sources.

Example Patents/Applications:

North America US8207541

Asia: CN101657672; JP5871357

Core Technologies for LED Signage Systems

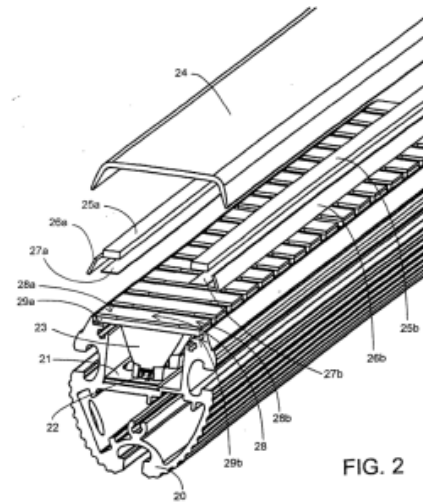
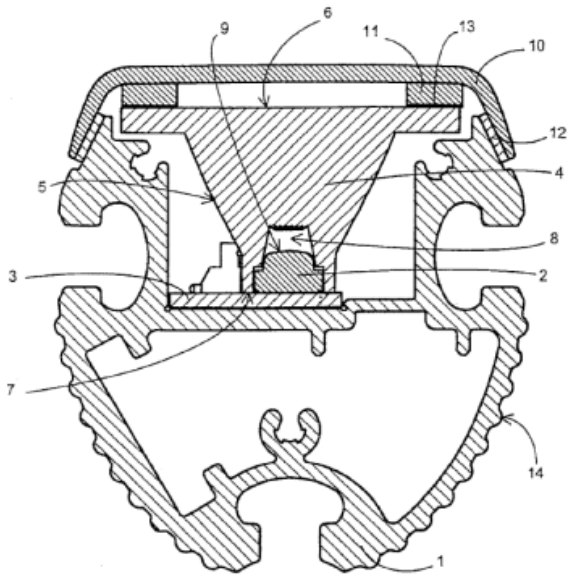

Light Mixing & Diffusion

Application: LED fixtures with optics

Advantage: Simplifies mounting of optics relative to LED

Example Patents/Applications:

North America: US6561690

Europe: EP1182396

Asia: JP4749623, CN01135741

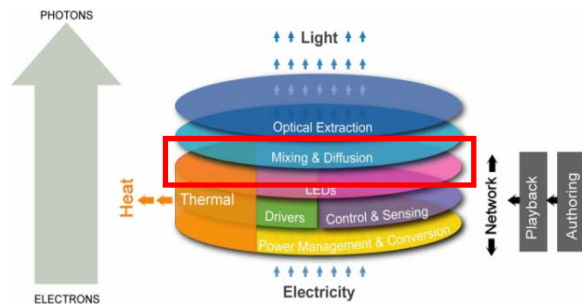

Core Technologies for LED Signage System

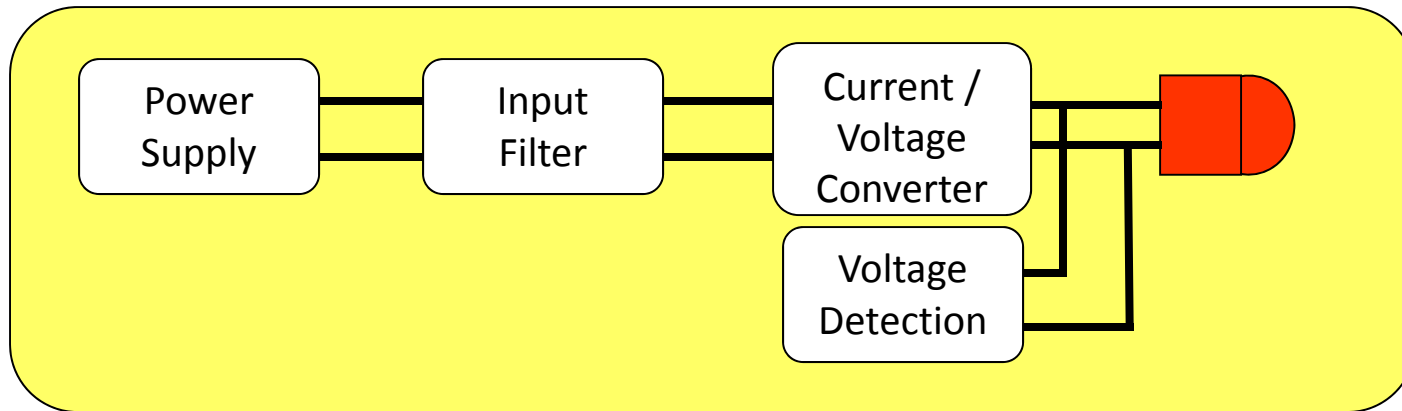

Control / Protection when changes in LED's occur

LED Driving

Application: Safe conventional light source replacement

Advantage: Allows accurate control and protection of driver circuitry in case of changes in the LED's at the output, such as over voltage, short circuits or malfunctioning of an individual LED in a string

Example Patents/Applications:

- North America: US6094014; US6577512; US6586890; US6972525
- Europe: EP0929992; EP1415518; EP1459599
- Asia: JP4260226; JP4657579; JP4353804; CN1241348

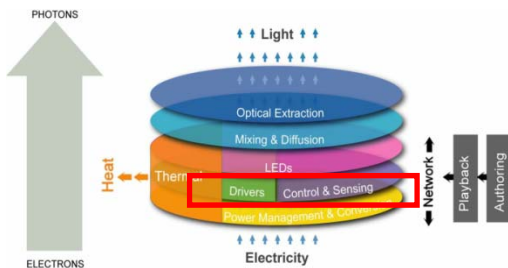

Core Technologies for LED Signage Systems

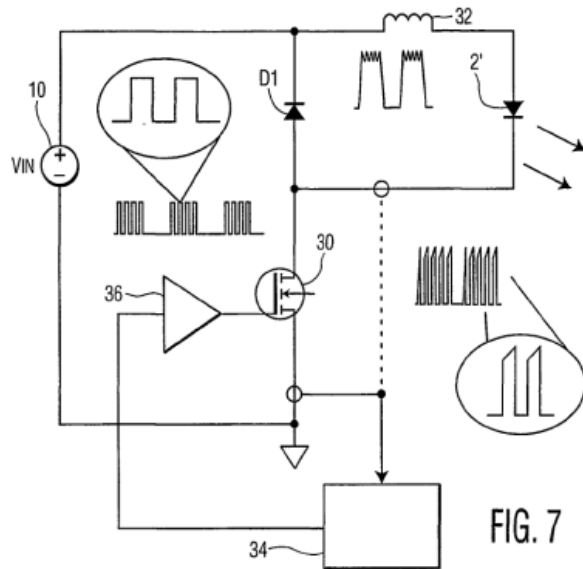
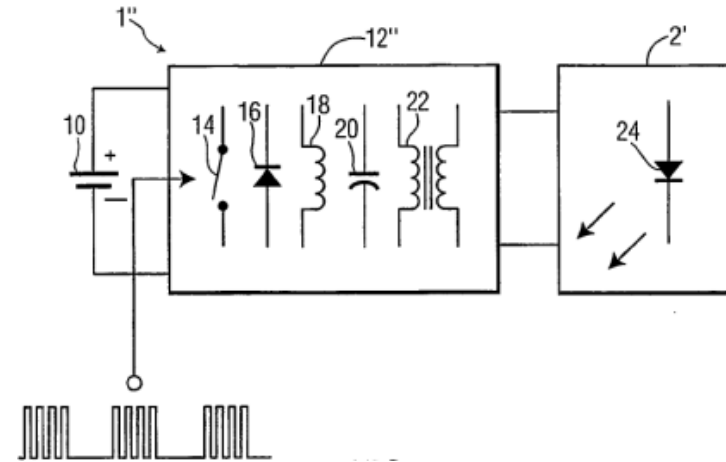

FIG. 7



LED Dimming

Application: PWM (e.g. 1-10 V) based LED dimming

Advantage: Efficient and full range linear LED dimming

Example Patents/Applications:

North America: US7071762

Europe: EP1576858B1

Asia: CN200380106654.2; JP4901104;

KR10-0978019

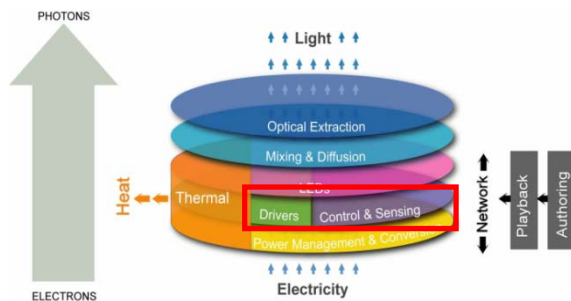

Core Technologies for LED Signage Systems

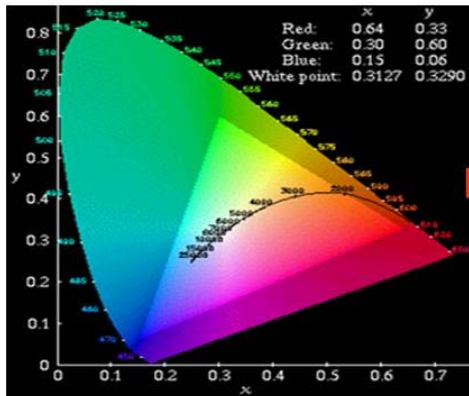

White Light Temperature Control

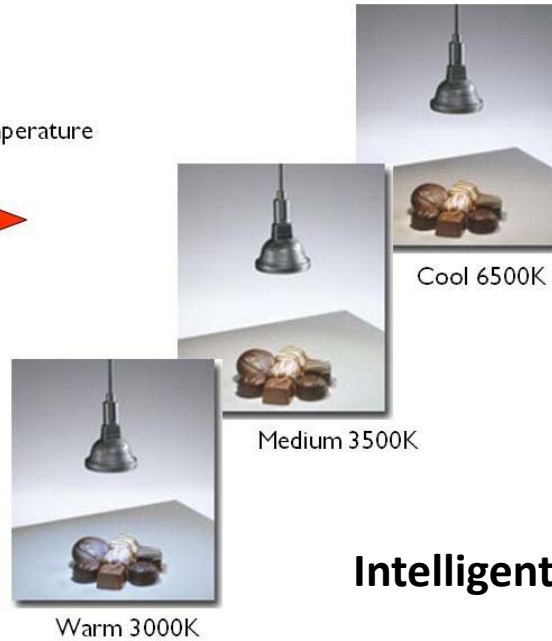

Intelligent White Light Illumination

Application: White color temperature control

Advantage: Produce high quality tunable white light

Example Patents/Applications:

North America: US7014336; 6636003; 6513949; 6234645

Europe: EP1016062; 1234140; 1118252; 1047904

Asia: JP02525836; 01542388; CN1289397; 1327707

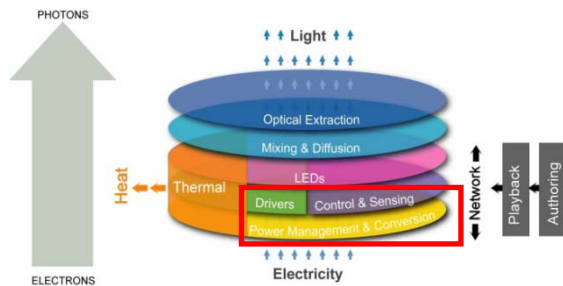

Core Technologies for LED Signage Systems

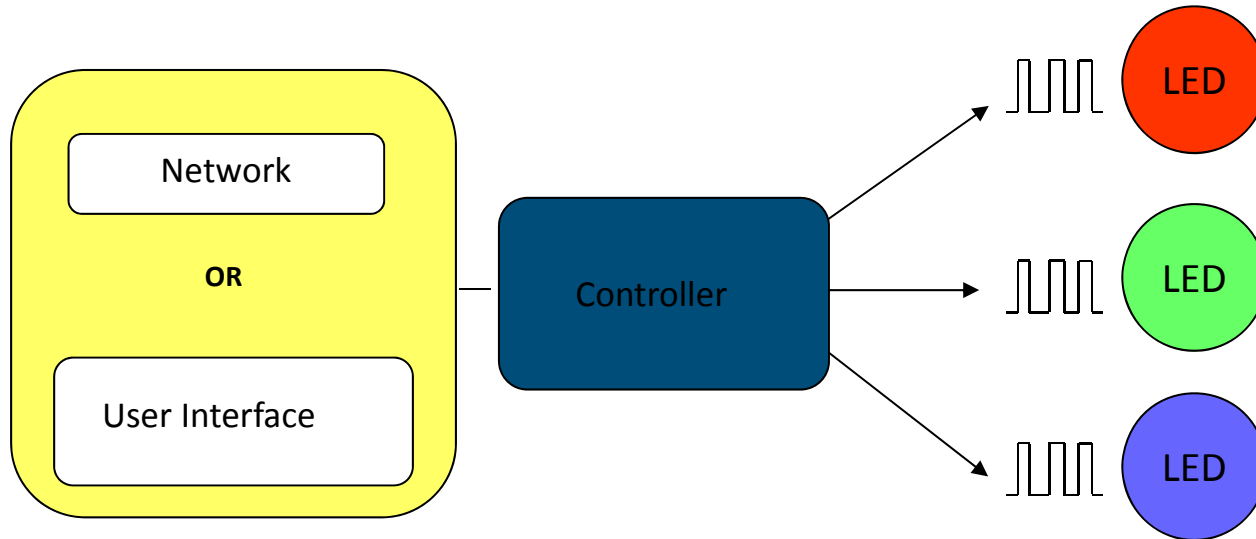

Intelligent Color Illumination

Current Switch

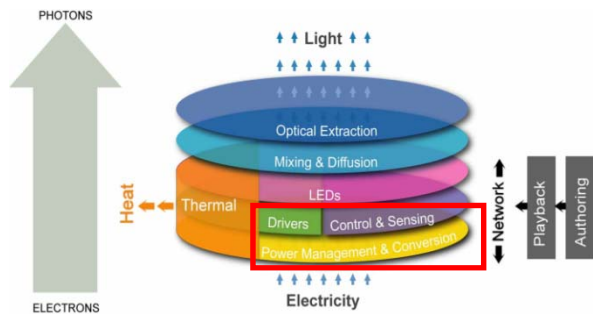

Application: Intelligent RGB color control

Advantage: Allows creating simple to sophisticated illumination effects

Example Patents/Applications:

North America: US6016038; 6788011; 6806659; 6234645

Europe: EP1016062; 1047904

Asia: HK1025416; JP02525836; CN1289397

Core Technologies for LED Signage Systems

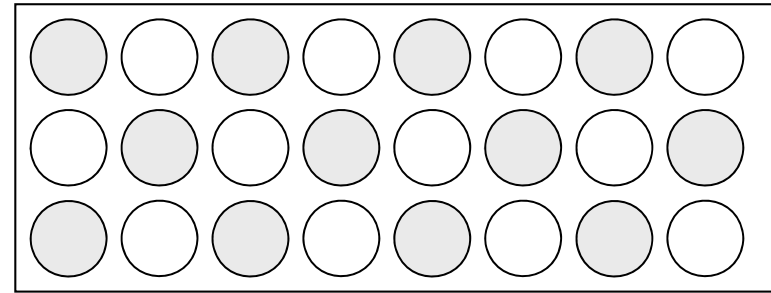
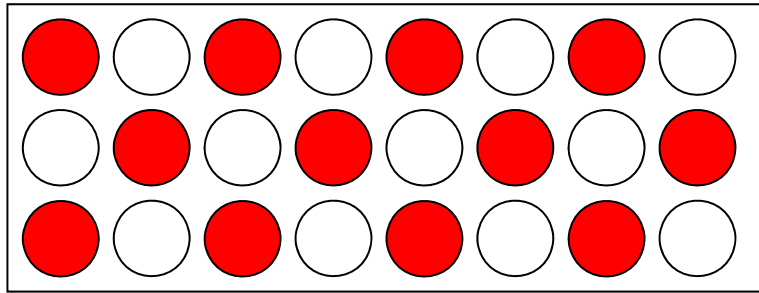

Mixing Light from Different LEDs

Application: Using two or more different LEDs to generate light (for single color or white, tunable white and color-changing)

Advantage: Achieve desired color of light or color temperature of white light, for both static and dynamic (e.g., color-changing) applications

Example Patents/Applications:

North America: US6692136; 6234648; 6234645; 6513949

Europe: EP1046196

Asia: JP4366016; JP4376464; IN210549; CN99802435.X; CN99802434; KR10-0702273; KR10-0776837; TW167039

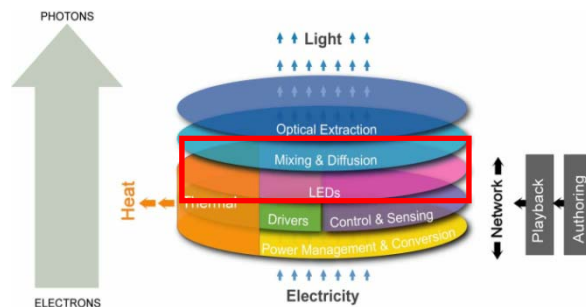

Core Technologies for LED Signage Systems

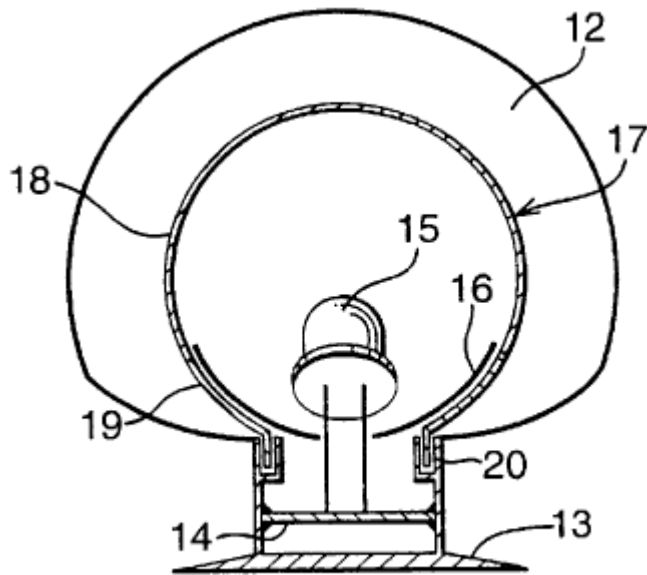

Apparatus and method for providing a linear effect

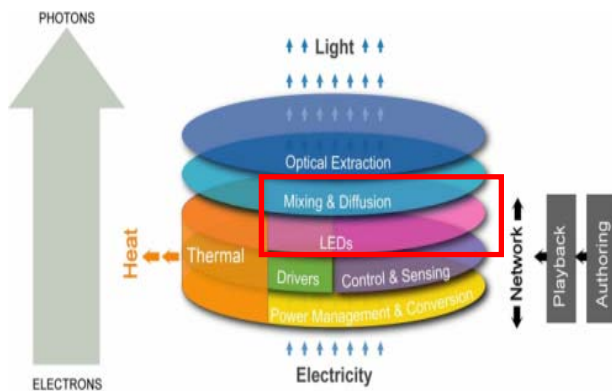

Application: Linear effect apparatus for lighting display

Advantage: Allows creating simple to sophisticated linear illumination effects

Example Patents/Applications:

North America: US7118248; 6676284

Europe: EP1110198; 1391650

