

PHILIPS

Strand Lighting

200F TV Fresnel LED Luminaire



Strand Lighting Offices

Philips Strand Lighting - Dallas
10911 Petal Street
Dallas, TX 75238
Tel: 214-647-7880
Fax: 214-647-8031

Philips Strand Lighting - Auckland
19-21 Kawana Street
Northcote, Auckland 0627
New Zealand
Tel: +64 9 481 0100
Fax: +64 9 481 0101

Philips Strand Lighting - New York
267 5th Ave, 4th Floor
New York, NY 10016
Tel: 212-213-8219
Fax: 212-532-2593

Philips Entertainment Group Eruope
Rondweg Zuid 85
Winterswijk 7102 JD Netherlands
Tel: +31 543-542343
Fax: +31 53 4500425

Philips Strand Lighting - Asia Limited
Unit C, 14/F
Roxy Industrial Centre,
No. 41 - 49 Kwai Cheong Road, Kwai Chung, N.T.
Hong Kong
Tel: +852 2796 9786
Fax: +852 2798 6546

Website :
www.strandlighting.com

The material in this manual is for information purposes only and is subject to change without notice. Strandlighting assumes no responsibility for any errors or omissions which may appear in this manual. For comments and suggestions regarding corrections and/or updates to this manual, please contact your nearest Strandlighting office.

El contenido de este manual es solamente para información y está sujeto a cambios sin previo aviso. Strandlighting no asume responsabilidad por errores o omisiones que puedan aparecer. Cualquier comentario, sugerencia o corrección con respecto a este manual, favor de dirijirlo a la oficina de Strandlighting más cercana.

Der Inhalt dieses Handbuchs ist nur für Informationszwecke gedacht, Aenderungen sind vorbehalten. Strandlighting uebernimmt keine Verantwortung für Fehler oder Irrtuemer, die in diesem Handbuch auftreten. Für Bemerkungen und Verbesserungsvorschlaege oder Vorschlaege in Bezug auf Korrekturen und/oder Aktualisierungen in diesem Handbuch, moechten wir Sie bitten, Kontakt mit der naechsten Strandlighting-Niederlassung aufzunehmen.

Le matériel décrit dans ce manuel est pour information seulement et est sujet à changements sans préavis. La compagnie Strandlighting n'assume aucune responsabilité sur toute erreur ou omission inscrite dans ce manuel. Pour tous commentaires ou suggestions concernant des corrections et/ou les mises à jour de ce manuel, veuillez s'il vous plait contacter le bureau de Strandlighting le plus proche.

Notes:

1. Information contained in this document may not be duplicated in full or in part by any person without prior written approval of Strandlighting. its sole purpose is to provide the user with conceptual information on the equipment mentioned. The use of this document for all other purposes is specifically prohibited.
 2. If the external flexible cable or cord of this luminaire is damaged, it shall be replaced by a special cord or cord exclusively available from the manufacturer or his service agent.
 3. The light source contained in this luminaire shall only be replaced by the manufacturer or his service agent or a similar qualified person.
 4. For controllable luminaires the classification of insulation that has been maintained between LV supply and control conductors shall be provided. E.g. basic insulation, reinforced insulation.
 5. Terminal block not included. Installation may require advice from a qualified person.
-

Document Number: **200F TV Fresnel LED Luminaires Users**

Version as of: 24-004-3875-00

200F TV Fresnel LED Luminaire Installation & User's Manual

©2016 Philips Group. All rights reserved.

IMPORTANT INFORMATION

Warnings and Notices

When using electrical equipment, basic safety precautions should always be followed including the following:



a. READ AND FOLLOW ALL SAFETY INSTRUCTIONS

- b. Do not use outdoors.
- c. Do not mount near gas or electric heaters.
- d. Equipment should be mounted in locations and at heights where it will not readily be subjected to tampering by unauthorized personnel.
- e. The use of accessory equipment not recommended by the manufacturer may cause an unsafe condition.
- f. Do not use this equipment for other than intended use.
- g. Refer service to qualified personnel.

SAVE THESE INSTRUCTIONS.



WARNING: You must have access to a main circuit breaker or other power disconnect device before installing any wiring. Be sure that power is disconnected by removing fuses or turning the main circuit breaker off before installation. Installing the device with power on may expose you to dangerous voltages and damage the device. A qualified electrician must perform this installation.

WARNING: Refer to National Electrical Code® and local codes for cable specifications. Failure to use proper cable can result in damage to equipment or danger to personnel.

WARNING: This equipment is intended for installation in accordance with the National Electric Code® and local regulations. It is also intended for installation in indoor applications only. Before any electrical work is performed, disconnect power at the circuit breaker or remove the fuse to avoid shock or damage to the control. It is recommended that a qualified electrician perform this installation.



WARNING! Remove all power from luminaire before installing lamp or performing any service. **THE LUMINAIRE PRODUCES EXTREME HEAT AND CAN BURN IF TOUCHED WITH BARE HANDS.** Allow unit to cool before servicing. Only use specified / approved lamps at the correct voltage with luminaire.

Additional Resources for DMX512

For more information on installing DMX512 control systems, the following publication is available for purchase from the United States Institute for Theatre Technology (USITT), "Recommended Practice for DMX512: A Guide for Users and Installers, 2nd edition" (ISBN: 9780955703522). USITT Contact Information:

USITT
6443 Ridings Road
Syracuse, NY 13206-1111 USA
1-800-93USITT
www.usitt.org

Philips Strand Lighting Limited Two-Year Warranty

Philips Strand Lighting offers a two-year limited warranty of its luminaires against defects in materials or workmanship from the date of delivery. A copy of Philips Strand Lighting two-year limited warranty containing specific terms and conditions can be obtained from the Philips Strand Lighting web site at www.strandlighting.com or by contacting your local Philips Strand Lighting office.

TABLE OF CONTENTS

Safety Information.....	Inside Front Cover
IMPORTANT INFORMATION	
Warnings and Notices.....	1
TABLE OF CONTENTS	
PREFACE	
About this Manual.....	3
Product Descriptions.....	3
ACCESSORIES.....	3
200F TV Fresnel LED LUMINAIRE OVERVIEW	
Major Components.....	4
200F TV Fresnel LED LUMINAIRE LCD Display/Menu System	
LCD Display/Menu System.....	5
INSTALLATION AND SET UP	
Power Requirements.....	6
Connecting Power.....	6
Connecting 200F TV Fresnel LED Luminaires to AC Power.....	7
Connecting to the DMX512 Network.....	8
Mounting Luminaires.....	9
OPERATION AND PROGRAM	
LCD Display and Menu System.....	10
LCD Display and Menu System Operation.....	10
USB Screen Display.....	10
Menu Structure.....	11
Parameter Detail.....	12
Button Functions.....	13
Dimming Curve Selection.....	14
DMX Control	
Basic 8-bit.....	15
Basic 16-bit.....	15
Simple 8-bit.....	15
200F TV Fresnel LED Luminaire RDM Parameter IDs	
200F TV Fresnel 5600K LED Luminaire RDM Parameter IDs.....	16
200F TV Fresnel 3200K LED Luminaire RDM Parameter IDs.....	19
MAINTENANCE AND CARE	
Special Cleaning Care Instruction.....	22
Front Diffusers Cleaning.....	22
Service and Maintenance.....	22
FEATURES AND SPECIFICATIONS	
200F TV Fresnel Technical Specification.....	23
200F TV Fresnel Dimensions.....	24

PREFACE

1. About this Manual

The document provides installation and operation instructions for the following products:

- 200F TV Fresnel Day Light P.O.
- 200F TV Fresnel Day Light M.O.
- 200F TV Fresnel Tungsten P.O.
- 200F TV Fresnel Tungsten M.O.

Please read all instructions before installing or using this product. Retain this manual for future reference. Additional product information and descriptions may be downloaded at www.strandlighting.com.

2. Product Descriptions

This manual covers the following 200F TV Fresnel LED Luminaire models:

- 200F TV Fresnel Tungsten M.O.
- 200F TV Fresnel Day Light M.O.
- 200F TV Fresnel Tungsten P.O.
- 200F TV Fresnel Day light P.O.

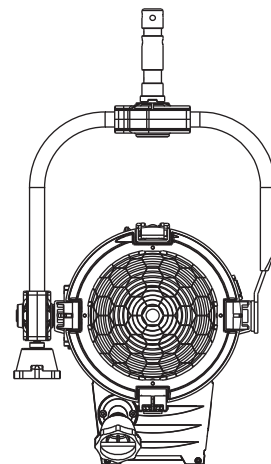
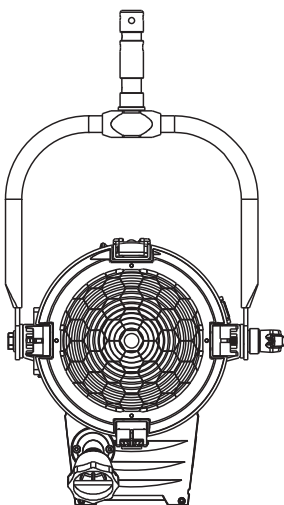

3. Accessories

- User Manual(this document)
- Power Input Cable 1.5m x1
- Filter Frame x1
- Rotating 4-leaf barn-door x1

200F TV Fresnel LED LUMINAIRE OVERVIEW

1. 200F TV Fresnel LED Luminaire Components

Major Luminaire Components

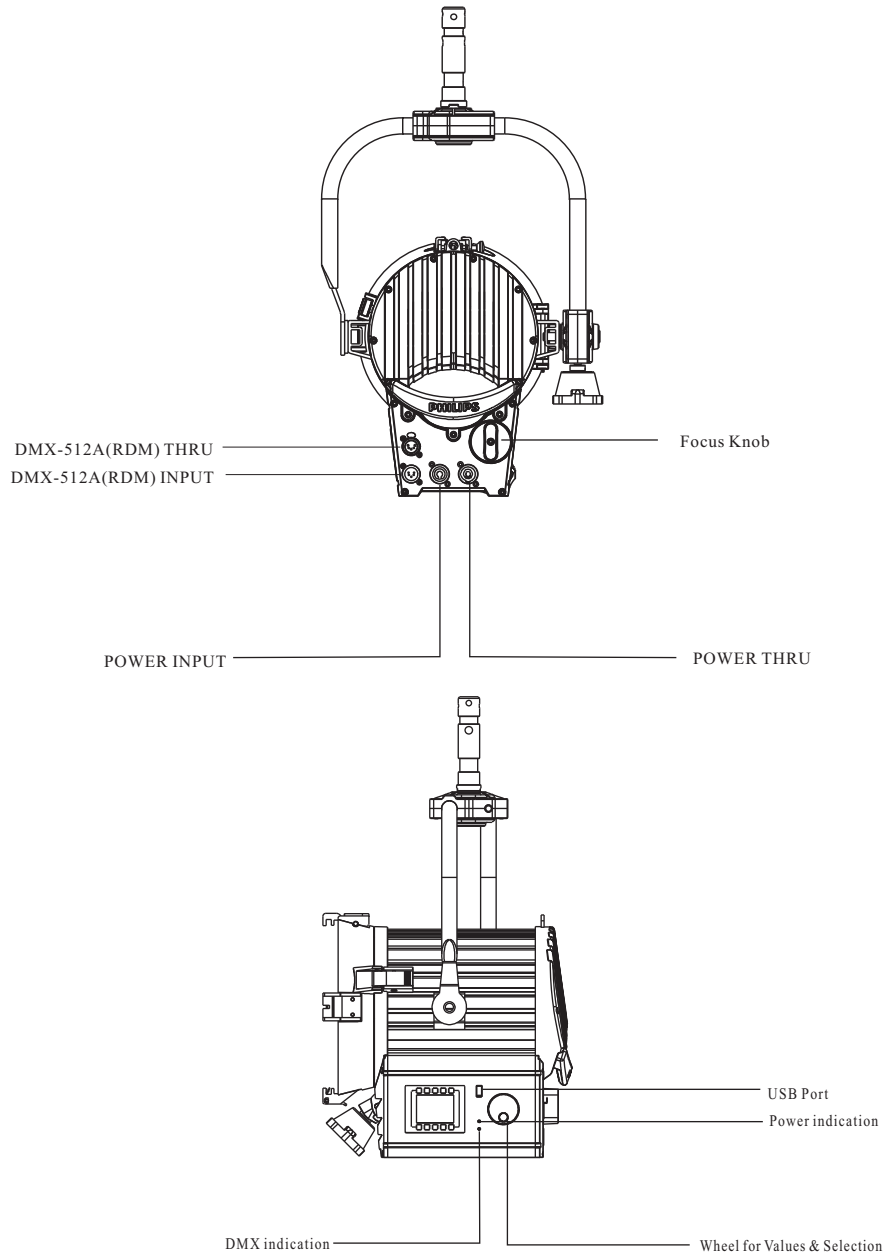

Figure 1: 200F TV Fresnel LED Luminaire Components

LCD Display/Menu System

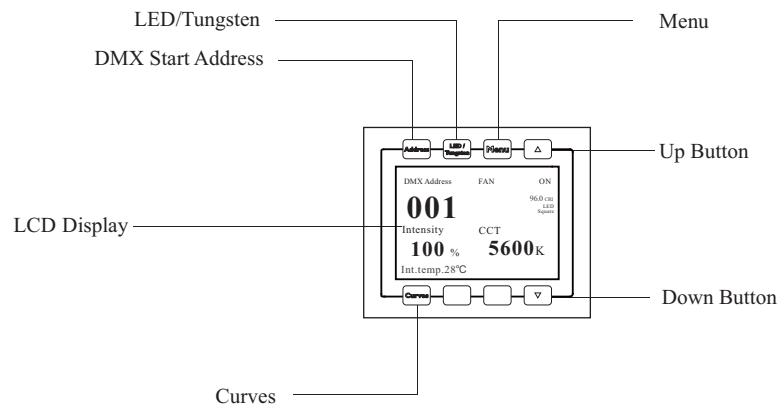

Figure 2: 200F TV Fresnel LED Luminaire LCD Display/Menu System

INSTALLATION AND SET UP

1. Power Requirements

The 200F TV Fresnel LED Luminaire operates on AC input voltages from 100 to 240 VAC.



WARNING! This unit does not contain an ON/OFF switch. Always disconnect power input cable to completely remove power from unit when not in use.

AC Power Operation

When connected to an AC source, the unit operates on 100 to 240 volts AC (+/- 10%, auto-ranging). The luminaire contains an auto-ranging power supply. Each luminaire can draw up to 180 Watts.



WARNING! Maximum 4 units in 120VAC or 8 units of 240VAC operation can be connected.

Table 1: 200F TV Fresnel LED Luminaire Voltage (VAC) vs. Current*

Voltage (AC)	Total Current (A)	Voltage (AC)	Total Current (A)
100	1.80A	180	1.00A
110	1.64A	190	0.95A
120	1.50A	200	0.90A
130	1.38A	210	0.86A
140	1.29A	220	0.82A
150	1.20A	230	0.78A
160	1.13A	240	0.75A
170	1.06A		

Note: For wiring of AC input connector, refer to "[Connecting 200F TV Fresnel LED Luminaires to AC Power](#)" on page 7.

2. Connecting Power

Units can be powered in one of two ways:

- Direct connection to an AC power source using an AC input cable. For wiring of AC input connector, refer to "[Connecting 200F TV Fresnel LED Luminaires to AC Power](#)" on page 7.
- Connection from the AC output of another 200F TV Fresnel LED Luminaire. When using this method, it is very important not to connect any other type of equipment device.



WARNING! Power THRU connect is only for next 200F TV Fresnel devices loop through.

3. Connecting 200F TV Fresnel LED Luminaires to AC Power

The unit is supplied with an AC input cable in bare end. Input connector is a user-supplied accessory to fit your application.

Table 2 describes how to connect power to your 200F TV Fresnel LED Luminaire. Field wiring of the 200F TV Fresnel LED Luminaire is straight forward. A total of 3 wires/conductors is supplied from the unit. The following wiring scheme is used:

Table 2: 200F TV Fresnel LED Luminaire (IP20 Rated Models) AC Input Connections

Wire Color	Purpose
Brown	Main/ LIVE (100 to 240VAC)
Blue	Neutral
Green/Yellow	Ground (Earth)

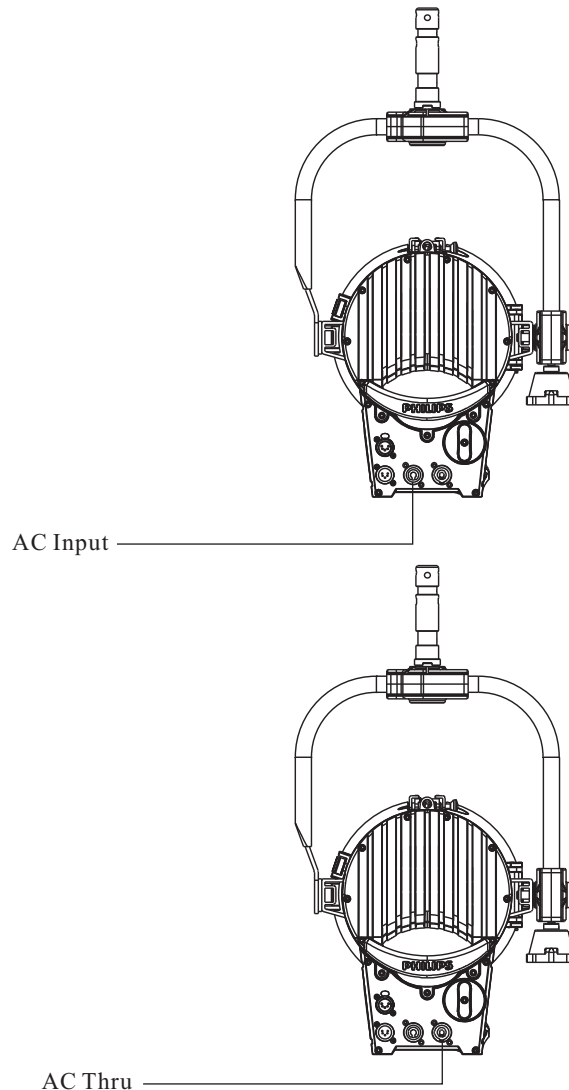

Figure 3: 200F TV Fresnel LED Luminaire AC Input & Output Connections

CAUTION: In the event the AC input cable of this luminaire is damaged, it must be replaced with an approved cable through an Authorized Strandlighting Dealer or Service Center.

4. Connecting to the DMX512 Network

DMX-512 network allow maximum of 32 units of 200F TV Fresnel on a single segment of DMX-512 cables loop through in daisy - chain. A cable runs from the control console (or DMX512 control source) to the DMX connector on the first 200F TV Fresnel LED Luminaire. Another cable runs from the other DMX connector first unit to a DMX connector on the next 200F TV Fresnel LED Luminaire.

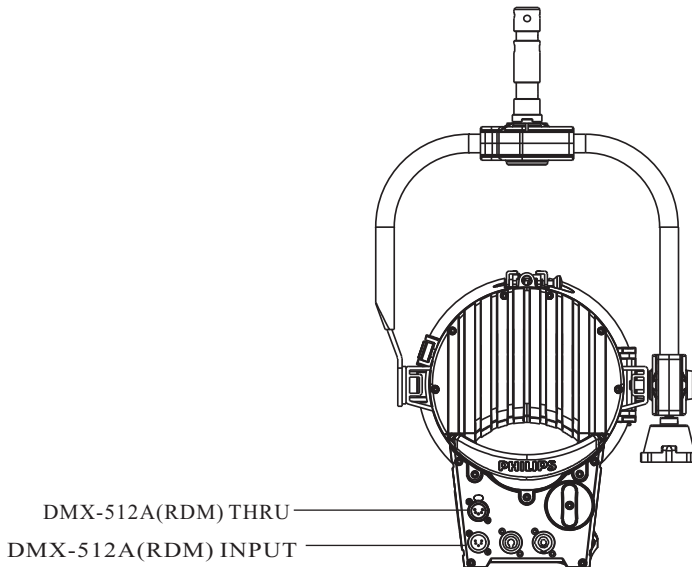

Figure 4: 200F TV Fresnel LED Luminaire DMX512 Input / Output Connections

Note: For more information on DMX512 networking and systems, refer to ["Additional Resources for DMX512"](#) on page 1. For 200F TV Fresnel LED Luminaire DMX Mapping, refer to ["DMX CONTROL"](#) on page 15.

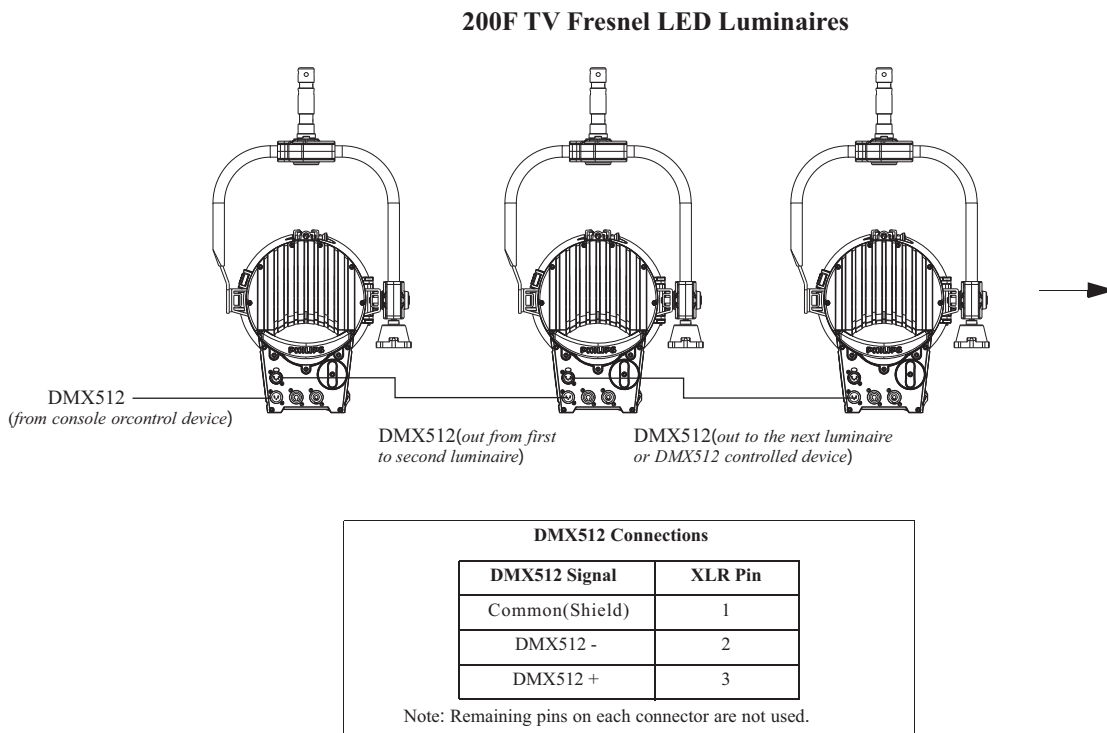

Figure 5: 200F TV Fresnel LED Luminaire - DMX512 Connections

5. Mounting Luminaire

The 200F TV Fresnel is provided with two mounts and one safety cable anchor points on the body. The luminaire is designed to accept a variety of mounting hooks, clamps, etc. Simply attach hook, clamp, etc. to the 200F TV Fresnel LED Luminaire mount assembly in the M13 hole. The illustrations below shows the different safety cable installation for both MO yoke and PO yoke version.

Refer to **Figure 6 and 7** for detailed mounting information.

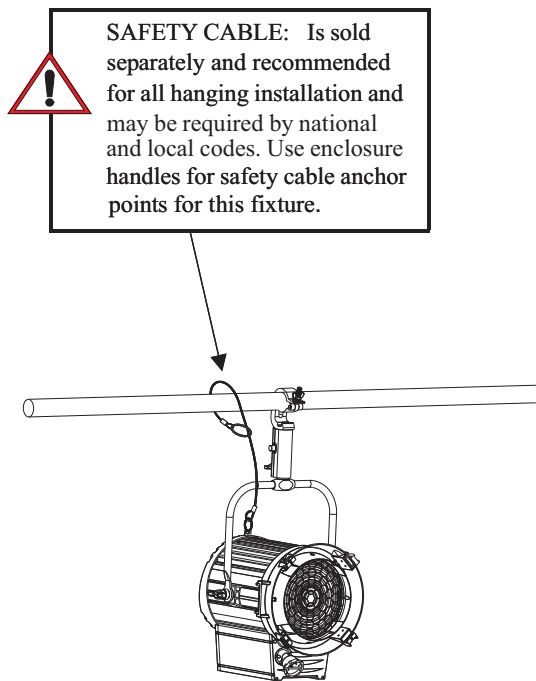

Figure 6: 200F TV Fresnel M.O.

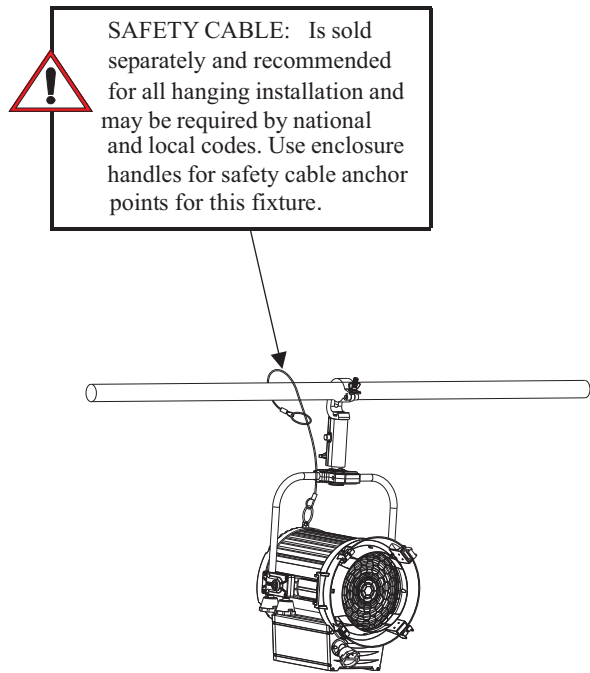

Figure 7: 200F TV Fresnel P.O.

Note: All optional accessories including the honeycomb and barndoor are sold separately. please refer to the detail on page 24 of this manual.

OPERATION AND PROGRAMMING

1. LCD Display and Menu System

Upon power up, the LCD will display the main screen. If DMX is enabled, the programmed address will appear after power up.

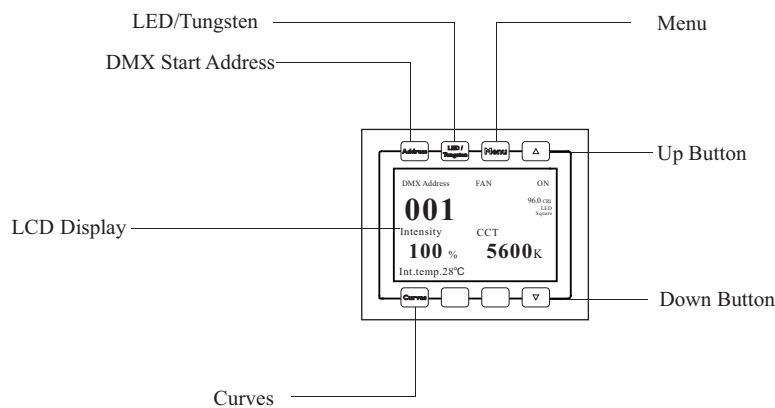

Figure 8: LCD Display and Menu System

2. LCD Display and Menu System Operation

Most of the often use functions can be select though the direct function keys and rotary wheel. Hidden setting, set of value or operation habit could be enable or disable under the MENU by Up/Down arrow.

To navigate and access the direct function keys or Menu setting / Selections :

- Step 1. Make sure unit is powered and turned on.
- Step 2. Press the desired button (as shown in **Figure 8**) to access the direct function keys
- Step 3. For MENU categories, use UP/DOWN arrow buttons to navigate through the various options and settings. For MENU categories
- Step 4. Make changes as desired via the Function Toggle.
- Step 5. Press the Function Toggle button to accept changes.

3. USB Screen Display

Firmware Upgrade :

Please insert USB 2.0 memory to the port, firmware file should be under the folder name of "UPDATE". Use wheel to confirm and go !

LOG. Files :

Please insert USB 2.0 memory to the port, working LOG files would be saved on it. Files saving may need times upon to the file size.

4. Menu Structure

200F TV Fresnel Daylight

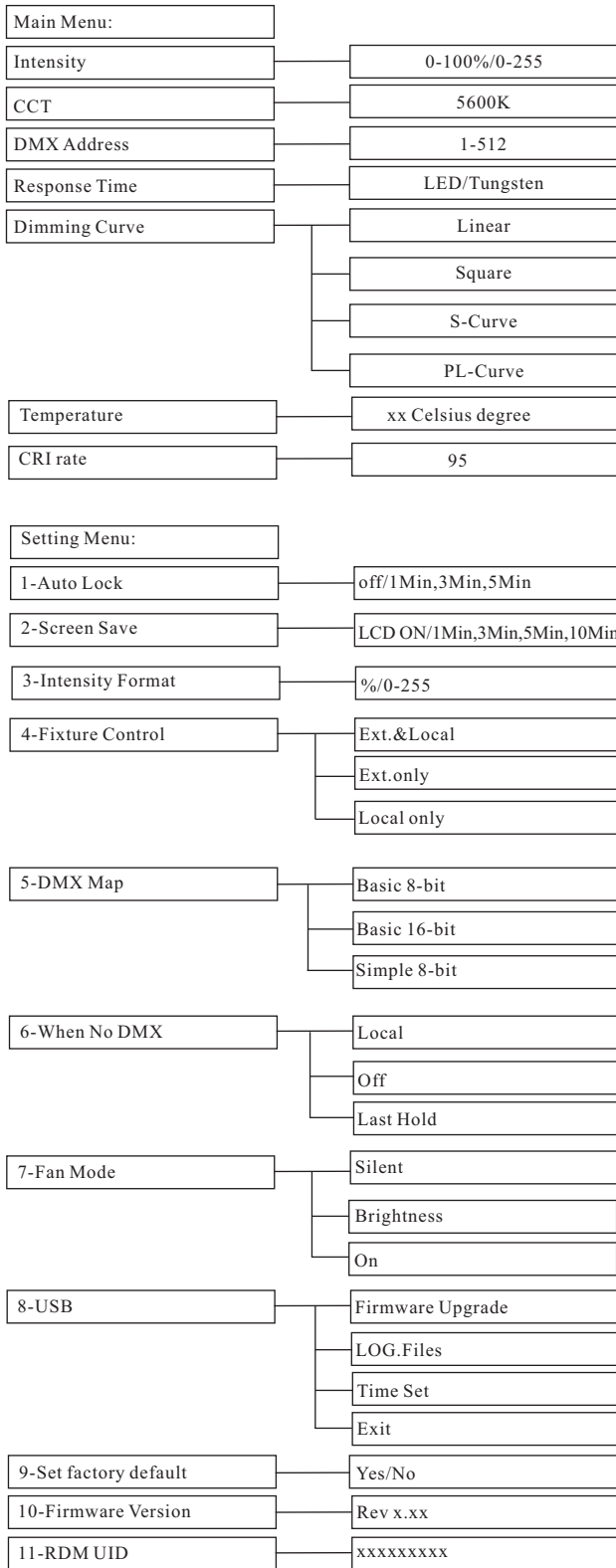

200F TV Fresnel Tungsten

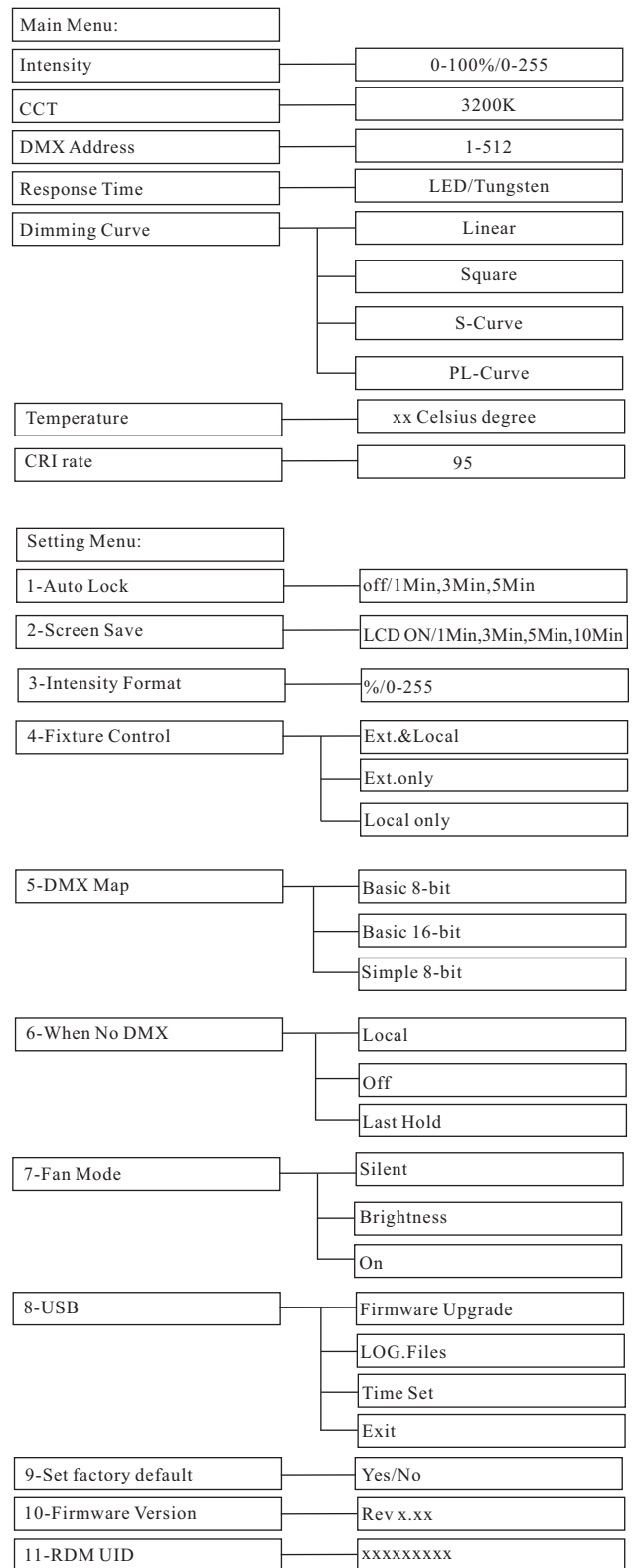

Figure 9: 200F TV Fresnel LED Luminaire Menu Structure

5. Parameter Detail

Table 3: 200F TV Fresnel LED Luminaire parameter detail

Parameter	Rang	Rang detail	RDM Support
Intensity	0-255	0-255	YES
CCT	3200k/5600k	5600	NO
DMX Address	1-512	1-512	YES
Response Time	0-1	0-LED 1-Tungsten	YES
Dimming Curve	0-3	0-Linear 1-Square 2-S-Curve 3-PL-Curve	YES
Auto Lock	0-3	0-Off 0-1Min 0-3Min 0-5Min	YES
Screen Save	0-4	0-LCD ON 1-1Min 2-3Min 3-5Min 4-10Min	YES
Intensity Format	0-1	0-% 1-0-255	YES
Fixture Control	0-2	0-Ext.&Local 1-Ext. only 2-Local only	YES
DMX Map	0-2	0-Basic 8-bit 1-Basic 16-bit 2-Simple 8-bit	YES
When No DMX	0-2	0-Local 1-Off 2-Last Hold	YES
Fan Mode	0-2	0-Silent 1-Brightness 2-On	YES
Set factory default	0-1	0-No 1-Yes	YES

6. Direct Function Keys

When in local control, The 200F TV Fresnel LED Luminaire's features can be accessed via the on-board LCD menu system or via the select buttons:

- DMX Start Address
- LED/Tungsten
- Curves
- Intensity

Address Button

To edit and save an Address:

- Step 1. Press Address button.
- Step 2. Rotate the Value Turn to increase/decrease the value.
- Step 3. Once at desired Address, push the Value Turn to confirm.
- Step 4. Address is now saved.

Address Setting

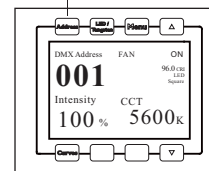

LED/Tungsten Button

To edit and save LED/Tungsten:

- Step 1. Press LED/Tungsten button.
- Step 2. Use the Value Turn to choose between LED or Tungsten.
- Step 3. Once the choice is made, push the Value Turn to confirm.
- Step 4. LED/Tungsten choice is now saved.

Choose between
LED/Tungsten

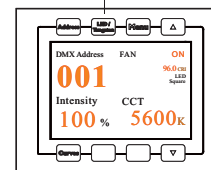

Curves Button

To edit and save a Curve:

- Step 1. Press Curves button.
- Step 2. Rotate the Value Turn to choose the curve between PL-Curve, S-Curve, Square and Linear.
- Step 3. Once the choice is made, push the Value Turn to confirm.
- Step 4. Curves choice is now saved.

Curve Selection

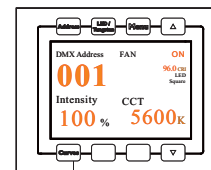

Intensity Button(Wheel)

To adjust the intensity:

- Step 1. Power on luminaire
- Step 2. Read the Intensity level in RED color on the LCD.
- Step 3. Turn the rotary wheel for levels
- Step 4. Click the wheel to confirm level

7. Dimming Curve Selection

Through the menu, you are able to select one of four dimming curves:

- Linear Curve
- PL_Curve
- S_Curve
- Square Curve

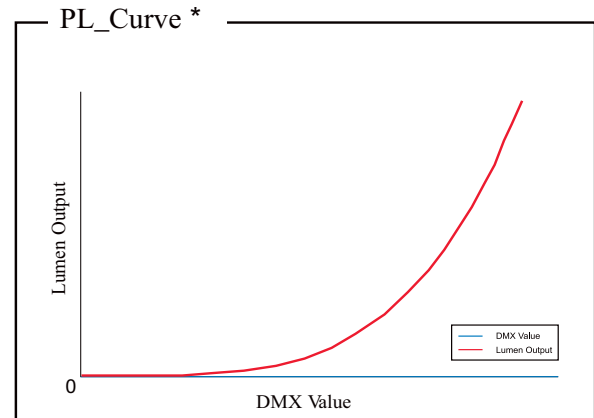
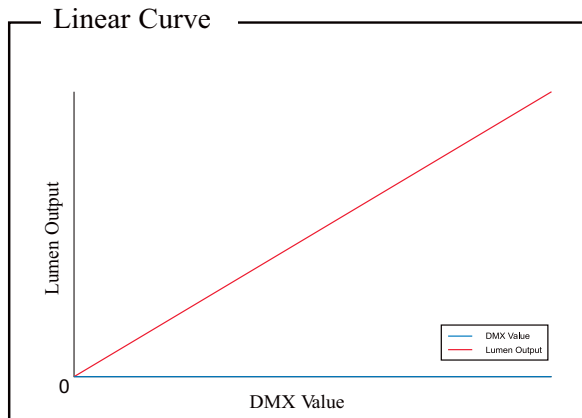

*PL Curve follows the dimming curve of Philips Selecon PL series LED luminaires.

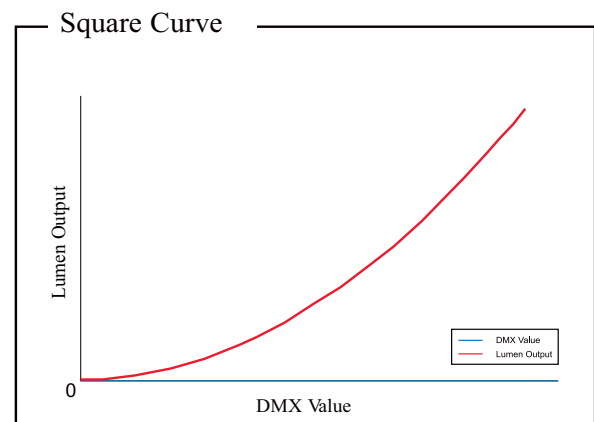
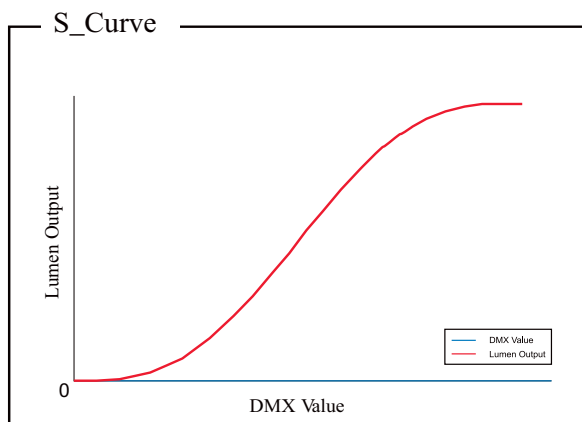

Figure 10: 200F TV Fresnel LED Luminaire Dimmer Curves

DMX CONTROL

This section contains information for operating the luminaire using DMX control in Basic 8-Bit, Basic 16-Bit, Simple 8-Bit modes. For Menu options and detailed information, see "LCD Display and Menu System" on page 10.

1. Simple 8-bit

Table 4 provides DMX channel mapping of all DMX512 control values when the 200F TV Fresnel LED Luminaire is in Simple 8-bit mode (as set by the luminaire's menu system).

Table 4: 200F TV Fresnel LED Luminaire DMX Channel Mapping (Simple 8-Bit Mode)

DMX	Parameter	Range DMX	Range%	Defaults*	Description
1	Intensity	0-255	0-100%	0	8 bit control for Intensity

2. Basic 8-bit

Table 5 provides DMX channel mapping of all DMX512 control values when the 200F TV Fresnel LED Luminaire is in Basic 8-bit mode (as set by the luminaire's menu system).

Table 5: 200F TV Fresnel LED Luminaire DMX Channel Mapping (Basic 8-Bit Mode)

DMX	Parameter	Range DMX	Range%	Defaults*	Description
1	Intensity	0-255	0-100%	0	8 bit control for Intensity of LED settings
2	Fading	0-255	0-100%	DMX 0	Time fading control of intensity 0% (Instant) 1% (1 sec) 2% (2 sec) 3% (3 sec) ... 100% (100 sec)

3. Basic 16-bit

Table 6 provides DMX channel mapping of all DMX512 control values when the 200F TV Fresnel LED Luminaire is in Basic 16-bit mode (as set by the luminaire's menu system).

Table 6: 200F TV Fresnel LED Luminaire DMX Channel Mapping (Basic 16-Bit Mode)

DMX	Parameter	Range DMX	Range%	Defaults*	Description
1	Intensity High	0-65535	0-100%	0	16 bit control for Intensity of LED settings
2	Intensity Low				
3	Fading	0-255	0-100%	DMX0	Time fading control of intensity 0% (Instant) 1% (1 sec) 2% (2 sec) 3% (3 sec) ... 100% (100 sec)

1. 200F TV Fresnel LED Luminaire RDM Parameter IDs

The following tables outline and describe all the RDM parameters IDs associated with 200F TV Fresnel LED Luminaires.

Table 7: 200F TV Fresnel Day Light LED Luminaire RDM Parameter IDs

Fresnel Day Light 200F					
UID					
MSB of ESTA 73H	LSB of ESTA 6cH	MSB of Unique Seq.	LSB of Unique Seq.	MSB of Unique Seq.	LSB of Unique Seq.
Model ID		0x1121		Project Category	
Manufacturer		Philips Strand Lighting Ltd.			
Model Description		Fresnel Day Light 200F			
Supported PIDs					
Get Allowed	Set Allowed	RDM Parameter IDs	Value	Comment	Implemented
Category - Network Management					
		DISC_UNIQUE_BRANCH	0x0001		■
		DISC_MUTE	0x0002		■
		DISC_UN_MUTE	0x0003		■
■		PROXIED_DEVICE	0x0010		
■		PROXIED_DEVICE_COUNT	0x0011		
■	■	COMMS_STATUS	0x0015		
Category -Status Collection					
■		QUEUED_MSSAGE	0x0020		
■		STATUS_MESSAGE	0x0030		
■		STATUS_ID_DESCRIPTION	0x0031		
	■	CLEAR_STATUS_ID	0x0032		
■	■	SUB_DEVICE_STATUS_REPORT_THR ESHOLD	0x0033		
Category-RDM Information					
■		SUPPORTED_PARAMETERS	0x0050	*Support required only if supporting Parameters Beyond the minimum required set.	■
■		PARAMETER_DESCRIPTION	0x0051	*Support required for Manufacturer-Specific PIDs exposed in SUPPORTED_PARAMETERS message	■
Category_Product Information					
■		DEVICE_INFO	0x0060		■
■		PRODUCT_DETAIL_ID_LIST	0x0070		
■		DEVICE_MODEL_DESCRIPTION	0x0080		■
■		MANUFACTURER_LABEL	0x0081		■
■	■	DEVICE_LABEL	0x0082		■
■	■	FACTORY_DEFAULTS	0x0090		■
■		LANGUAGE_CAPABILITIES	0x00A0		
■	■	LANGUAGE	0x00B0		■
■		SOFTWARE_VERSION_LABEL	0x00C0		
■		BOOT_SOFTWARE_VERSION_ID	0x00C1		
■		BOOT_SOFTWARE_VERSION_LABEL	0x00C2		

Table 8: 200F TV Fresnel Day Light LED Luminaire RDM Parameter IDS

Get Allowed	Set Allowed	RDM Parameter IDs	Value	Comment	Implemented
Category - DMX512 Setup					
■	■	DMX_PERSONALITY	0x00E0		■
■		DMX_PERSONALITY_DESCRIPTION	0x00E1		■
■	■	DMX_START_ADDRESS	0x00F0	*Required if device uses a DMX Slot	■
■		SLOT_INFO	0x0120		■
■		SLOT_DESCRIPTION	0x0121		■
		DEFLAUT_SLOT_VALUE	0x0122		
Category - Sensors 0x02xx					
■		SENSOR_DEFINITION	0x0200		■
■	■	SENSOR_VALUE	0x0201		■
	■	RECORD_SENSORS	0x0202		
Category_Dimmer Settings 0x03xx Future					
Category_Power/Lamp Setting 0x04xx					
■	■	DEVICE_HOURS	0x0400		
■	■	LAMP_HOURS	0x0401		
■	■	LAMP_STRIKES	0x0402		
■	■	LAMP_STATE	0x0403		
■	■	LAMP_ON_MODE	0x0404		
■	■	DEVICE_POWER_CYCLES	0x0405		
Category_Display Settings 0x05xx					
■	■	DISPLAY_INVERT	0x0500		
■	■	DISPLAY_LEVEL	0x0501		
Category_Configuration 0x06xx					
■	■	PAN_INVERT	0x0600		
■	■	TILT_INVERT	0x0601		
■	■	PAN_TILT_SWAP	0x0602		
■	■	REAL_TIME_CLOCK	0x0603		
Category_Control 0x10xx					
■	■	IDENTIFY_DEVICE	0x1000		■
	■	RESET_DEVICE	0x1001		
■	■	POWER_STATE	0x1010		
■	■	POWER_STATE	0x1010		
■	■	PERFORM_SELFTEST	0x1020		
■		SELF_TEST_DESCRIPTION	0x1021		
	■	CAPTURE_PRESET	0x1030		
■	■	PRESET_PLAYBACK	0x1031		

Table 9: 200F TV Fresnel Day Light LED Luminaire RDM Manufacturer Specific PIDS For Root Device

Manufacturer Specific PIDs										
Manufacturer Defined PIDS range is 0x8000-0xffdf. See Table A-3, ANSI EI.20-2010										
Get Allowed	Set Allowed	RDM Parameter ID	TYPE	LENGTH	UNIT	PREFIX	MIN	MAX	DEFAULT	DESCRIPTION
■	■	8A00H	U8	1	NONE	NONE	0	100	100	Dimmer
■	■	8AA1H	U8	1	NONE	NONE	0	3	3	Dimming Curve
■	■	8A0CH	U8	1	NONE	NONE	0	2	2	When No DMX
■	■	8A42H	U8	1	NONE	NONE	0	1	0	Response Time
■	■	8A41H	U8	1	NONE	NONE	0	3	0	Auto Lock
■	■	810AH	U8	1	NONE	NONE	0	1	0	Intensity Format
■	■	8106H	U8	1	NONE	NONE	0	2	0	Fixture Control
■	■	8A97H	U8	1	NONE	NONE	0	2	0	Fan Control
■	■	A5D5H	U8	1	NONE	NONE	0	4	0	Screen Save

Table 10: 200F TV Fresnel Tungsten LED Luminaire RDM Parameter IDs

Fresnel Tungsten 200F					
UID					
MSB of ESTA 73H	LSB of ESTA 6cH	MSB of Unique Seq.	LSB of Unique Seq.	MSB of Unique Seq.	LSB of Unique Seq.
Model ID		0x1120		Project Category	
Manufacturer		Philips Strand Lighting Ltd.			
Model Description		Fresnel Tungsten 200F			
Supported PIDs					
Get Allowed	Set Allowed	RDM Parameter IDs	Value	Comment	Implemented
Category - Network Management					
		DISC_UNIQUE_BRANCH	0x0001		■
		DISC_MUTE	0x0002		■
		DISC_UN_MUTE	0x0003		■
■		PROXIED_DEVICE	0x0010		
■		PROXIED_DEVICE_COUNT	0x0011		
■	■	COMMS_STATUS	0x0015		
Category -Status Collection					
■		QUEUED_MSSAGE	0x0020		
■		STATUS_MESSAGE	0x0030		
■		STATUS_ID_DESCRIPTION	0x0031		
	■	CLEAR_STATUS_ID	0x0032		
■	■	SUB_DEVICE_STATUS_REPORT_THR ESHOLD	0x0033		
Category-RDM Information					
■		SUPPORTED_PARAMETERS	0x0050	*Support required only if supporting Parameters Beyond the minimum required set.	■
■		PARAMETER_DESCRIPTION	0x0051	*Support required for Manufacturer-Specific PIDs exposed in SUPPORTED_PARAMETERS message	■
Category_Product Information					
■		DEVICE_INFO	0x0060		■
■		PRODUCT_DETAIL_ID_LIST	0x0070		
■		DEVICE_MODEL_DESCRIPTION	0x0080		■
■		MANUFACTURER_LABEL	0x0081		■
■	■	DEVICE_LABEL	0x0082		■
■	■	FACTORY_DEFAULTS	0x0090		■
■		LANGUAGE_CAPABILITIES	0x00A0		
■	■	LANGUAGE	0x00B0		
■		SOFTWARE_VERSION_LABEL	0x00C0		■
■		BOOT_SOFTWARE_VERSION_ID	0x00C1		
■		BOOT_SOFTWARE_VERSION_LABEL	0x00C2		

Table 11 : 200F TV Fresnel Tungsten LED Luminaire RDM Parameters IDS

Get Allowed	Set Allowed	RDM Parameter IDs	Value	Comment	Implemented
Category - DMX512 Setup					
■	■	DMX_PERSONALITY	0x00E0		■
■		DMX_PERSONALITY_DESCRIPTION	0x00E1		■
■	■	DMX_START_ADDRESS	0x00F0	*Required if device uses a DMX Slot	■
■		SLOT_INFO	0x0120		■
■		SLOT_DESCRIPTION	0x0121		■
		DEFLAUT_SLOT_VALUE	0x0122		
Category - Sensors 0x02xx					
		SENSOR_DEFINITION	0x0200		■
■	■	SENSOR_VALUE	0x0201		■
	■	RECORD_SENSORS	0x0202		
Category_Dimmer Settings 0x03xx Future					
Category_Power/Lamp Setting 0x04xx					
■	■	DEVICE_HOURS	0x0400		
■	■	LAMP_HOURS	0x0401		
■	■	LAMP_STRIKES	0x0402		
■	■	LAMP_STATE	0x0403		
■	■	LAMP_ON_MODE	0x0404		
■	■	DEVICE_POWER_CYCLES	0x0405		
Category_Display Settings 0x05xx					
■	■	DISPLAY_INVERT	0x0500		
■	■	DISPLAY_LEVEL	0x0501		
Category_Configuration 0x06xx					
■	■	PAN_INVERT	0x0600		
■	■	TILT_INVERT	0x0601		
■	■	PAN_TILT_SWAP	0x0602		
■	■	REAL_TIME_CLOCK	0x0603		
Category_Control 0x10xx					
■	■	IDENTIFY_DEVICE	0x1000		■
	■	RESET_DEVICE	0x1001		
■	■	POWER_STATE	0x1010		
■	■	POWER_STATE	0x1010		
■	■	PERFORM_SELFTEST	0x1020		
■		SELF_TEST_DESCRIPTION	0x1021		
	■	CAPTURE_PRESET	0x1030		
■	■	PRESET_PLAYBACK	0x1031		

Table 12: 200F TV Fresnel Tungsten LED Luminaire RDM Manufacturer Specific PIDS For Root Device

Manufacturer Specific PIDs										
Manufacturer Defined PIDS range is 0x8000-0xffdf. See Table A-3, ANSI E1.20-2010										
Get Allowed	Set Allowed	RDM Parameter ID	TYPE	LENGTH	UNIT	PREFIX	MIN	MAX	DEFAULT	DESCRIPTION
■	■	8A00H	U8	1	NONE	NONE	0	100	100	Dimmer
■	■	8AA1H	U8	1	NONE	NONE	0	3	3	Dimming Curve
■	■	8A0CH	U8	1	NONE	NONE	0	2	2	When No DMX
■	■	8A42H	U8	1	NONE	NONE	0	1	0	Response Time
■	■	8A41H	U8	1	NONE	NONE	0	3	0	Auto Lock
■	■	810AH	U8	1	NONE	NONE	0	1	0	Intensity Format
■	■	8106H	U8	1	NONE	NONE	0	2	0	Fixture Control
■	■	8A97H	U8	1	NONE	NONE	0	2	0	Fan Control
■	■	A5D5H	U8	1	NONE	NONE	0	4	0	Screen Save

CLEANING AND CARE



WARNING! All cleaning should be performed with power completely removed from the luminaire. Never remove protective covers when luminaire is powered. Wear appropriate protective eye wear and gloves when cleaning the fixture. All service and maintenance, other than described herein, should be performed by a qualified technician or Authorized Service Center.

1. Clean and Care Instructions

Being a solid-state fixture, and unlike most fixtures, the 200F TV Fresnel LED Luminaire requires very little routine maintenance by the user. This section covers portions of the luminaire that can be removed for cleaning.

The 200F TV Fresnel LED Luminaire special care when it comes to cleaning front lens assembly. Additional care needs to be taken with the plastic components because they are much easier to scratch or damage than glass.

The following is a list of cleaning materials required to care for your 200F TV Fresnel LED Luminaire:

- Lint free lens tissue
- Lint or powder free gloves
- Reagent grade isopropyl alcohol*
- A mild soap solution.

Note: *Reagent grade isopropyl alcohol is good to use on the 200F TV Fresnel LED Luminaire plastic optics with anti-reflection coating

If the lens is still dirty after using isopropyl alcohol, for instance if fingerprints or oil is just redistributed and not cleaned off the optic, then a mild soap and water solution can be used to gently wash the lens. Repeat the cleaning with isopropyl alcohol to eliminate streaks and soap residue.



WARNING! Under no circumstances should ammonia-based cleaners, acetone, or other harsh solvents be used on or near the 200F TV Fresnel LED Luminaire. These types of cleaners or solvents can permanently damage the optics or housings of the fixture.

If you have any questions regarding the use or care of your 200F TV Fresnel LED Luminaire, please contact Strandlighting technical support or your local Authorized Dealer.

2. Front Diffusers Cleaning

To clean the front diffusers:

- Step 1. Disconnect luminaire from power and allow to cool completely.
- Step 2. Apply a small amount of reagent grade alcohol to lint-free lens tissue.
- Step 3. Wipe all debris, dirt, fingerprints, etc. from diffusers.
- Step 4. Using a second lint-free lens tissue, wipe off any alcohol residue.

3. Service and Maintenance

For all other service and maintenance issues, please contact your local Strandlighting office or an Authorized Service Center.



WARNING! Disassembly (other than as described herein), alterations, unauthorized service, etc. will void the product warranty. Contact your local Strandlighting office or an Authorized Service Center for technical support and service.

TECHNICAL SPECIFICATIONS

1. 200F TV Fresnel LED Luminaire Operational Specifications

Zoom Range:	12-60 deg(4&1/2Turns)
Light Output:	4170 lx (5m approx) For Tungsten 4530 lx (5m approx) For Day Light
Color Temperature:	3200K(Tungsten) 5600K(Daylight)
Input Voltage (AC):	100V to 240V (+/- 10%, auto-ranging)
Power Consumption:	180 Max
Frequency:	50/60Hz
Control:	DMX512 (1990) / DMX512A (RDM) / On-Board Menu
Ambient Temperature:	0 to 37 Degrees C (0 to 98.6 Degrees F)
Humidity:	5%-95% Non condensing
Net Weight:	7.9kg(P.O.) /7.4kg(M.O.)
Housing:	Die-casting, extrusion aluminum
IP Rating:	IP20
Dimension	593×326×603.1mm(M.O.)/435×415.6×691mm(P.O.)

Note: Common model specifications shown. For specific model specifications, features, and accessories, refer to the product specification sheet for more details.

2. 200F TV Fresnel LED Luminaire Dimensions

200F TV Fresnel with MO Yoke

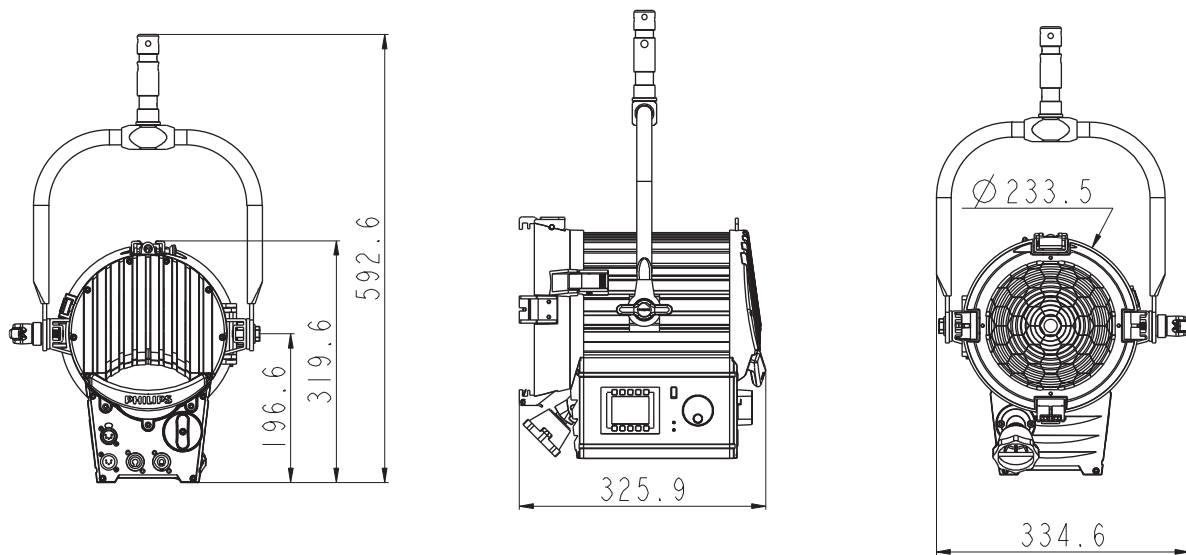

Figure 11: 200F TV Fresnel M.O. Yoke

200F TV Fresnel with PO Yoke

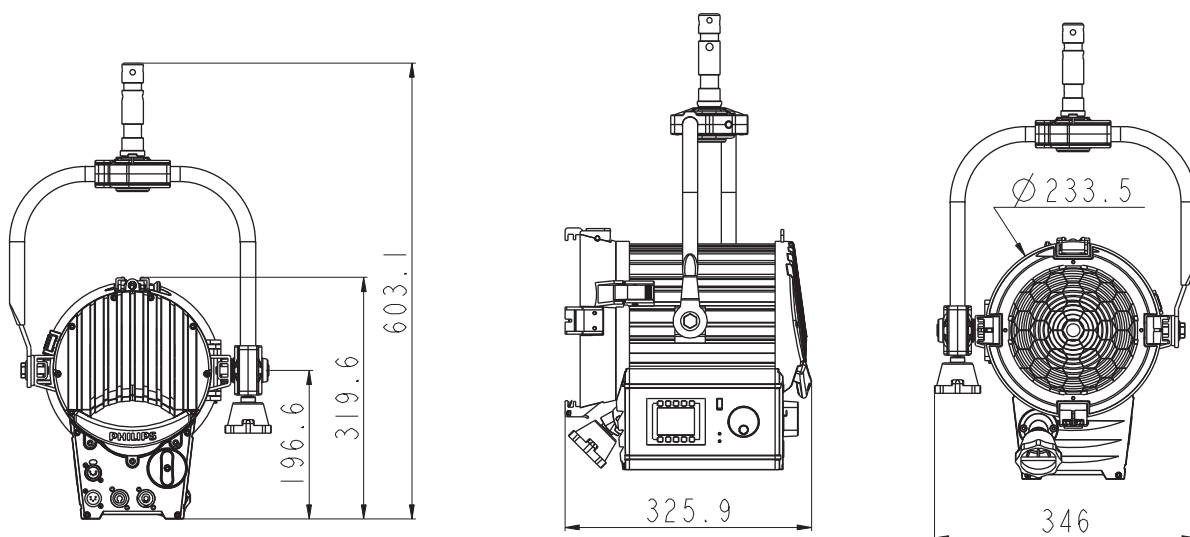

Figure 12: 200F TV Fresnel LED With P.O. Yoke



PHILIPS

Strand Lighting

Strand Lighting
Dallas
10911 Petal Street
Dallas, TX 75238
Tel: 214-647-7880
Fax: 214-647-8031

Strand Lighting
New York
267 5th Ave, 4th Floor,
New York, NY 10016
Tel: 212-213-8219
Fax: 212-532-2593

Strand Lighting Asia Limited
Unit C, 14/F, Roxy Industrial Centre
No.41-49 Kwai Cheong Road
Kwai Chung, N.T., Hong Kong
Tel: +852 2796 9786
Fax: +852 2798 6545

Strand Selecon
Auckland
19-21 Kawana Street
Northcote, Auckland 0627
New Zealand
Tel: +64 9 481 0100
Fax: +64 9 481 0101

Philips Entertainment Group Europe
Rondweg Zuid 85
Winterswijk 7102 JD Netherlands
Tel: +31 543-542343
Fax: +31 53 4500425

www.strandlighting.com