

Showline

SL BAND 300

PHILIPS



The Showline SL BAND 300 is part of a range of LED luminaires designed for the entertainment market providing rugged construction combined with high performance LED sources. Showline luminaires are designed to work together to match color, dimming and operation simplifying set up and allowing you to plan your production knowing you will get consistent light from every luminaire.

The Showline SL BAND 300 is a compact rugged luminaire available in either an IP20 or an IP65 model for outdoor applications. Available in tunable white or full color mixing RGBW models the SL BAND 300 delivers exceptional light output. The luminaire accepts a range of standard beam spread accessories to adjust the standard 10° beam spread and hanging hardware suitable for any installation.

Features :

- Rugged Construction
- Philips LumiLeds RGBW LED's for exceptional output and color
- Built-in color presets, effects and chases
- HSIC (Hue - Saturation - Intensity - Color temperature) operation mode
- 8 or 16-bit DMX-512A operation for smooth stepless fades
- On-board LCD Menu System for addressing and setup
- Remote configuration available via RDM
- PowerCon in and thru power connections
- 5-pin DMX-512A(RDM) in and thru connections

Drawing Diagram :

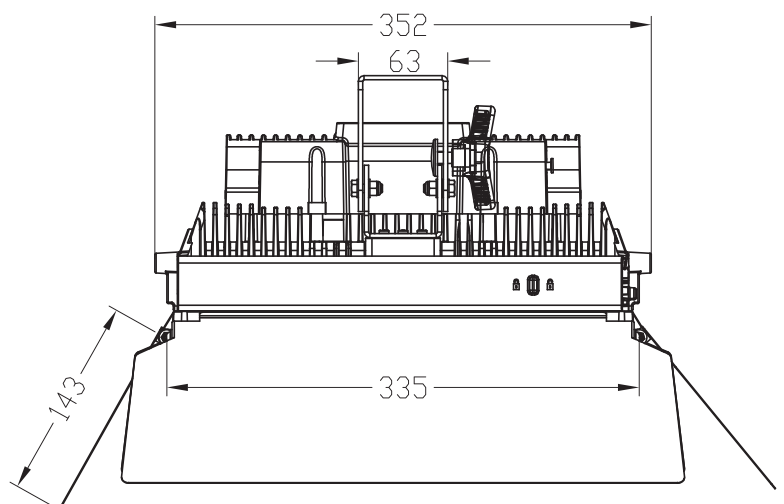
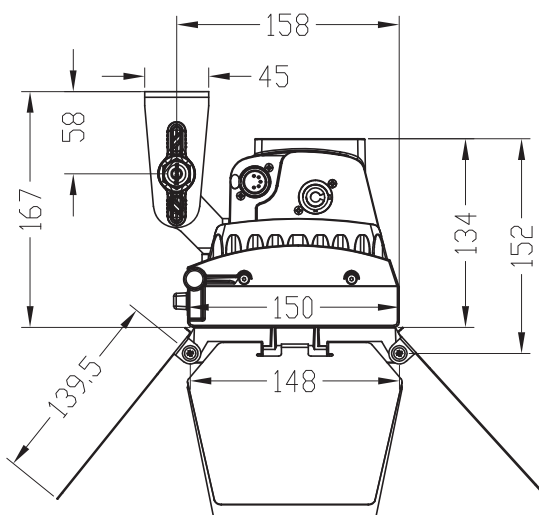

Technical Specifications :

Version:

SL BAND 300 RGBW, IP20
 SL BAND 300 RGBW, IP65
 SL BAND 300 Tunable White , IP20
 SL BAND 300 Tunable White , IP65

Physical:

90-240VAC, 65W
 352mm x 160mm x 133mm, 5kg
 CE

Optics:

10 degree beam angle(20° diffuser applied)
 36 high power LEDs

Luminance:

2000 lumens
 CRI/CQS:
 >90 (RGBW)

Controls:

DMX-512A(RDM)
 Local LCD control
 Master/slave

Features:

Color Gel filter preset
 Chase - Strobe + Duration Effect Engine
 LED & Tungsten Curves selection

Modes:

HSIC
 8 bit RGBW
 16 bit RGBW



Ordering Information :

SL300C20-B	SL BAND 300 RGBW black body IP20
SL300C20-W	SL BAND 300 RGBW white body IP20
SL300W20-B	SL BAND 300 Tunable white black body IP20
SL300W20-W	SL BAND 300 Tunable white white body IP20
SL300C65-B	SL BAND 300 RGBW black body IP65
SL300C65-W	SL BAND 300 RGBW white body IP65
SL300W65-B	SL BAND 300 Tunable white black body IP65
SL300W65-W	SL BAND 300 Tunable white white body IP65

SL300BD-B	4-leaf Barndoor Black
SL300BD-W	4-leaf Barndoor White
SL300DIF20	20 degree diffuser (spare)
PC 1BE	1m powercord bare
PC 3BE	3m powercord bare
PC 8BE	8m powercord bare

Harmonize Color Calibration Technology

At the heart of all Showline products is Philips Harmonize Calibration technology. Harmonize is a proprietary, advanced LED color matching system, consisting of 3 correction modules: RGB, RGBW and Cool White/Warm White. Every Showline fixture undergoes rigorous testing to provide you with consistent control of color and intensity as well as output of the highest quality.

Philips Group 2012. All rights reserved.

The Company reserves the right to make any variation in design or construction to the equipment described.

E&OE. Philips Entertainment delivers fully integrated lighting solutions; from simple lamps to complete systems designed with the specific needs of the entertainment and specialized display lighting markets.

