

PHILIPS

Strand Lighting

CONTACT

Low Voltage Lighting Control Panels

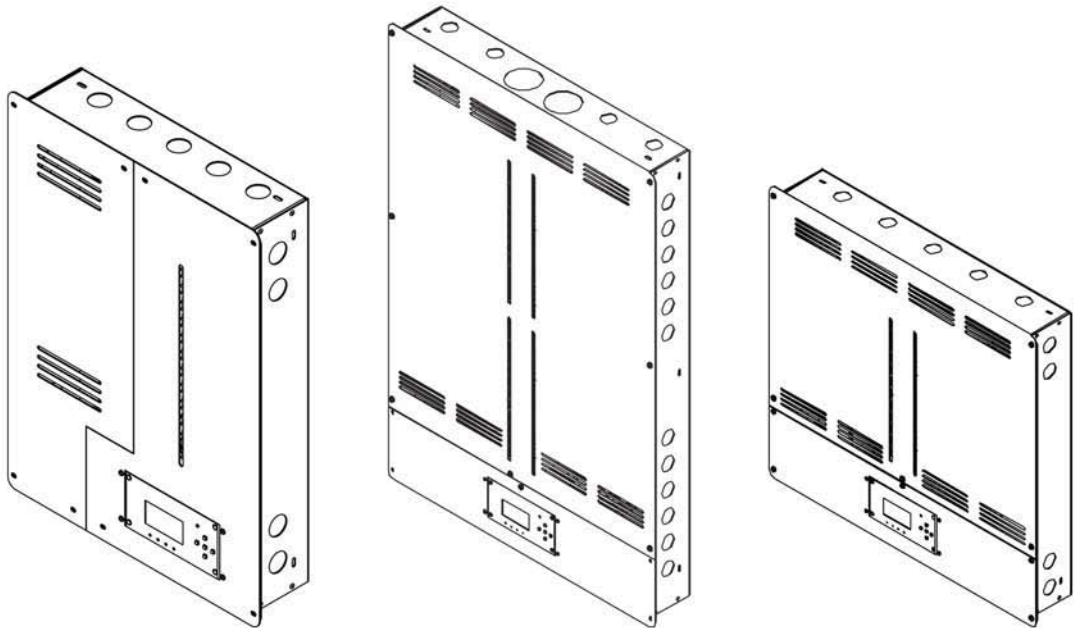

12-Circuit / 24-Circuit / 36-Circuit / 42-Circuit / 48-Circuit

Models:

76910, 76911, 76912, 76913, 76921C,
76922C, 76923C, 76931C, 76932C, 76933C

Strand Lighting Offices

Strand Lighting - Dallas

10911 Petal Street
Dallas, TX 75238
Tel: 214-647-7880
Fax: 214-647-8031

Strand Lighting - New York

267 5th Ave, 4th Floor
New York, NY 10016
Tel: 212-213-8219
Fax: 212-532-2593

Strand Lighting - Asia Limited

Unit C, 14/F, Roxy Industrial Centre
No. 41-49 Kwai Cheong Road
Kwai Chung, N.T., Hong Kong
Tel: +852 2796 9786
Fax: +852 2798 6545

Strand Selecon - Auckland

19-21 Kawana Street
Northcote, Auckland 0627
New Zealand
Tel: +64 9 481 0100
Fax: +64 9 481 0101

Strand Lighting - Europe

Marssteden 152
Enschede 7547 TD
The Netherlands
Tel: +31 53 4500424
Fax: +31 53 4500425

Website:

www.strandlighting.com

The material in this manual is for information purposes only and is subject to change without notice. Strand Lighting assumes no responsibility for any errors or omissions which may appear in this manual. For comments and suggestions regarding corrections and/or updates to this manual, please contact your nearest Strand Lighting office.

El contenido de este manual es solamente para información y está sujeto a cambios sin previo aviso. Strand Lighting no asume responsabilidad por errores o omisiones que puedan aparecer. Cualquier comentario, sugerencia o corrección con respecto a este manual, favor de dirijirlo a la oficina de Strand Lighting más cercana.

Der Inhalt dieses Handbuches ist nur für Informationszwecke gedacht, Aenderungen sind vorbehalten. Strand Lighting uebernimmt keine Verantwortung für Fehler oder Irrtuemer, die in diesem Handbuch auftreten. Für Bemerkungen und Verbesserungsvorschlaege oder Vorschlaege in Bezug auf Korrekturen und/oder Aktualisierungen in diesem Handbuch, moechten wir Sie bitten, Kontakt mit der naechsten Strand Lighting-Niederlassung aufzunehmen.

Le matériel décrit dans ce manuel est pour information seulement et est sujet à changements sans préavis. La compagnie Strand Lighting n'assume aucune responsabilité sur toute erreur ou ommission inscrite dans ce manuel. Pour tous commentaires ou suggestions concernant des corrections et/ou les mises à jour de ce manuel, veuillez s'll vous plait contacter le bureau de Strand Lighting le plus proche.

Information contained in this document may not be duplicated in full or in part by any person without prior written approval of Strand Lighting. Its sole purpose is to provide the user with conceptual information on the equipment mentioned. The use of this document for all other purposes is specifically prohibited.

Document Number: **2-450330-010**

Version as of: **26 September 2011**

Contact Low Voltage Lighting Control Panel Installation & Operation Guide

©2011 Philips Group. All rights reserved.

IMPORTANT SAFEGUARDS

When using electrical equipment, basic safety precautions should always be followed including the following:



- a. **READ AND FOLLOW ALL SAFETY INSTRUCTIONS.**
- b. Do not use outdoors.
- c. Do not mount near gas or electric heaters.
- d. Equipment should be mounted in locations and at heights where it will not readily be subjected to tampering by unauthorized personnel.
- e. The use of accessory equipment not recommended by the manufacturer may cause an unsafe condition.
- f. Do not use this equipment for other than intended use.
- g. Refer service to qualified personnel.

SAVE THESE INSTRUCTIONS.



WARNING: You must have access to a main circuit breaker or other power disconnect device before installing any wiring. Be sure that power is disconnected by removing fuses or turning the main circuit breaker off before installation. Installing the device with power on may expose you to dangerous voltage and damage the device. A qualified electrician must perform this installation.

WARNING: Refer to National Electrical Code® and local codes for cable specifications. Failure to use proper cable can result in damage to equipment or danger to persons.

WARNING: This equipment is intended for installation in accordance with the National Electric Code® and local regulations. It is also intended for permanent installation in indoor applications only. Before any electrical work is performed, disconnect power at the circuit breaker or remove the fuse to avoid shock or damage to the control. It is recommended that a qualified electrician perform this installation.

CAUTION: Wire openings **MUST** have fittings or lining to protect wires/cables from damage. Use 75° C copper wire only! Aluminum wire may not be used.

TABLE OF CONTENTS

Strand Lighting Offices	Inside Front Cover
Important Safeguards	
Table of Contents	
Preface	
About this Guide.....	4
Additional Resources.....	4
Other Manuals	4
Additional Resources for DMX512.....	4
Overview	
About Contact Low Voltage Lighting Control Panels	5
Circuit Breaker Models (MLO - Main Lug Only).....	6
Installation Overview.....	7
Tools List	7
Location and Clearances.....	7
Installation	
Mounting the Panel.....	8
Connecting Line/Load Wiring	9
Control Wiring.....	9
Configuration Using RCM LCD Menu	
Overview.....	11
Menu Operation.....	11
Menu System	12
Walk Around Programming Procedures.....	16
Setting Keypad to Factory Default Mode.....	16
Assign One Keypad Address.....	16
Multiple with Same Address	16
Multiple with Auto Increment.....	17
Assign Relays to Room	17
Edit Vision.net Presets.....	17
Auto Assign VN (Vision.net) Channels	18
Time Clock Operation and Programming.....	18
View Current Events	18
Add/Edit Time Clock Events.....	18
Add/Edit Time Clock Actions	19
Set Time.....	19
Set Date	19
Set Location.....	20
Emergency Lighting Operation (UL924)	
Overview.....	21
Appendix A: Standard Wiring	
DMX512	22
Vision.net Networks (RS485 over CAT5e)	22
Termination of Shielded Cable	23
Termination of Ethernet Cable.....	24

Master/Slave Wiring 25

Panic Input..... 25

Appendix B: Specifications

12-Circuit Relay Panel (76910)..... 26

24-Circuit Relay Panel (76911)..... 27

36-Circuit Relay Panel (76912)..... 28

48-Circuit Relay Panel (76913)..... 29

24-Way Relay Insert Panel w/ Breakers (76921C/76931C)..... 30

36-Way Relay Insert Panel with Circuit Breakers (76922C/76932C)..... 31

42-Way Relay Insert Panel with Circuit Breakers (76923C/76933C)..... 32

Catalog Number Reference

Contact Panels and Enclosures (Rough-In Boxes)..... 33

Contact Options and Accessories 34

Notice To Contractor

Technical Services Checkout Procedure 35

PREFACE

1. About this Guide

The document provides installation and operation instructions for the following Contact Low Voltage Relay Panel products:

Contact Relay Panels - individually fed

- 76910 Relay Insert Panel, 12-circuit
- 76911 Relay Insert Panel, 24-circuit
- 76912 Relay Insert Panel, 36-circuit
- 76913 Relay Insert Panel, 48-circuit

Contact Relay Panel Power Modules with 3-phase input and breakers for 120 volt power supplies

- 76921C Relay Insert Panel with Breakers, 24-way
- 76922C Relay Insert Panel with Breakers, 36-way
- 76923C Relay Insert Panel with Breakers, 42-way

Contact Relay Panel Power Modules with 3-phase input and breakers for 277 volt power supplies

- 76931C Relay Insert Panel with Breakers, 24-way
- 76932C Relay Insert Panel with Breakers, 36-way
- 76933C Relay Insert Panel with Breakers, 42-way

For complete specifications, refer to "[Appendix B: Specifications](#)" on page 26. For Options and Accessories, see "[Contact Options and Accessories](#)" on page 34.

Please read all instructions before installing or using this product. Retain this guide for future reference.

2. Additional Resources

Other Manuals

Strand Lighting's Dimmer.net software provides an advanced interface for configuring Contact Lighting Control System options. Where applicable, refer to the Dimmer.net manual for full explanations of each configuration option.

Dimmer.net software and manuals may be downloaded at www.strandlighting.com.

Additional Resources for DMX512

For more information on installing DMX512 control systems, the following publication is available for purchase from the United States Institute for Theatre Technology (USITT), "Recommended Practice for DMX512: A Guide for Users and Installers, 2nd edition" (ISBN: 9780955703522). USITT Contact Information:

USITT
315 South Crouse Avenue, Suite 200
Syracuse, NY 13210-1844 USA
1-800-938-7488 or 1-315-463-6463
www.usitt.org

OVERVIEW

1. About Contact Low Voltage Lighting Control Panels

Contact Low-Voltage Lighting Control Panels provide advanced control of various lighting load types (Incandescent, Tungsten, Halogen, Magnetic Low-Voltage, Electronic Low-Voltage, Neon, Non-Dim Fluorescent, and HID) and allow any combination of control, including scheduling via an astronomical time clock or occupant control through the use of Vision.net control stations.

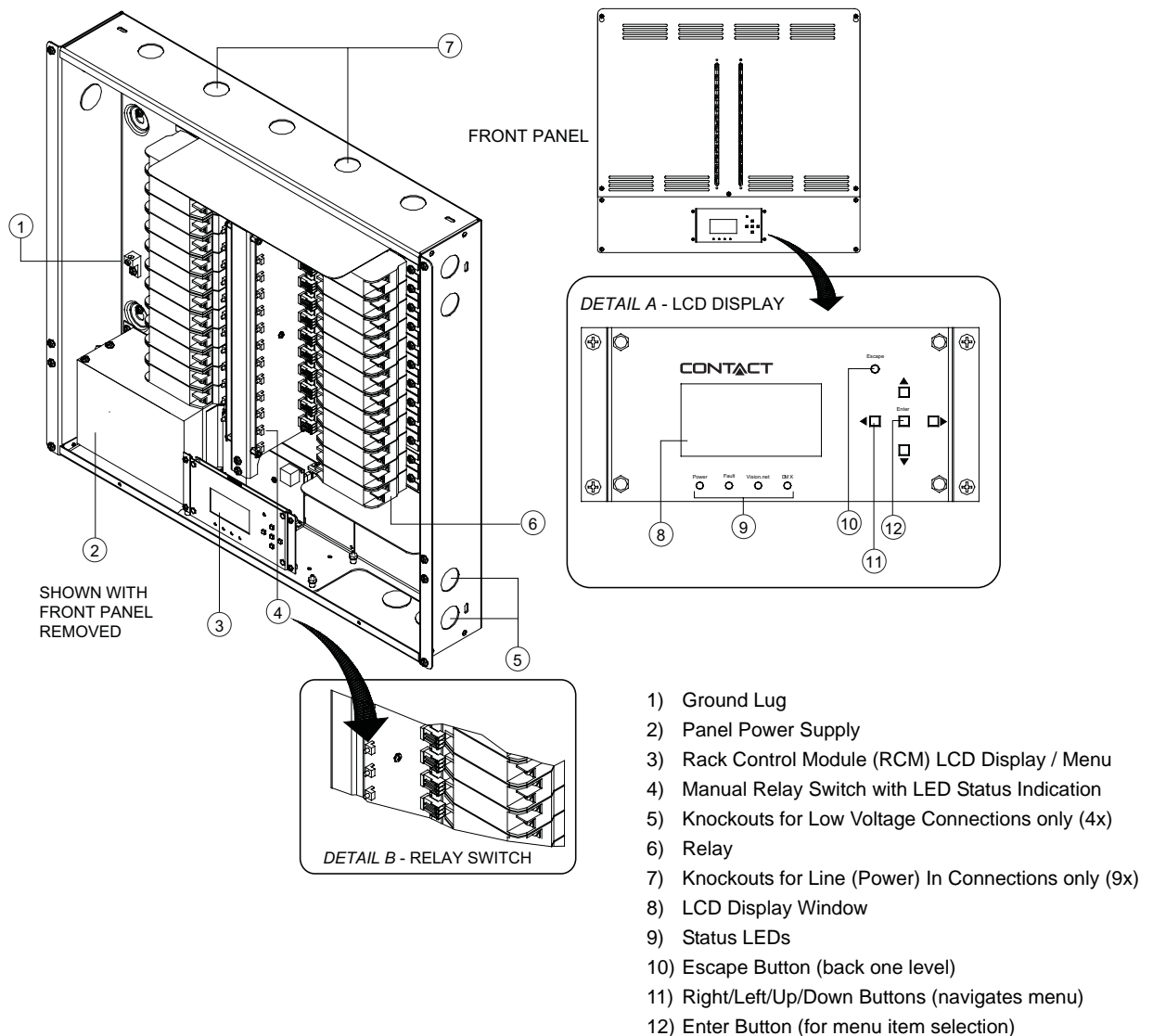

Figure 1: Lighting Control Panel Overview

Note: The Contact 24-Circuit Panel is shown in this example, however, components are typical for all models.

2. Circuit Breaker Models (MLO - Main Lug Only)

Some models of the Contact Low Voltage Lighting Control Panel include internal branch circuit breakers. In this case, a breaker access door is included on the front panel. MLO option is only available on the following models:

Model	Description	Voltage
76921C	Relay Insert Panel with breakers, 24-way	120V
76922C	Relay Insert Panel with breakers, 36-way	120V
76923C	Relay Insert Panel with breakers, 42-way	120V
76931C	Relay Insert Panel with breakers, 24-way	277V
76932C	Relay Insert Panel with breakers, 36-way	277V
76933C	Relay Insert Panel with breakers, 42-way	277V

Note: MLO option is not available on 12 and 48-relay models.

Refer to the diagram below:

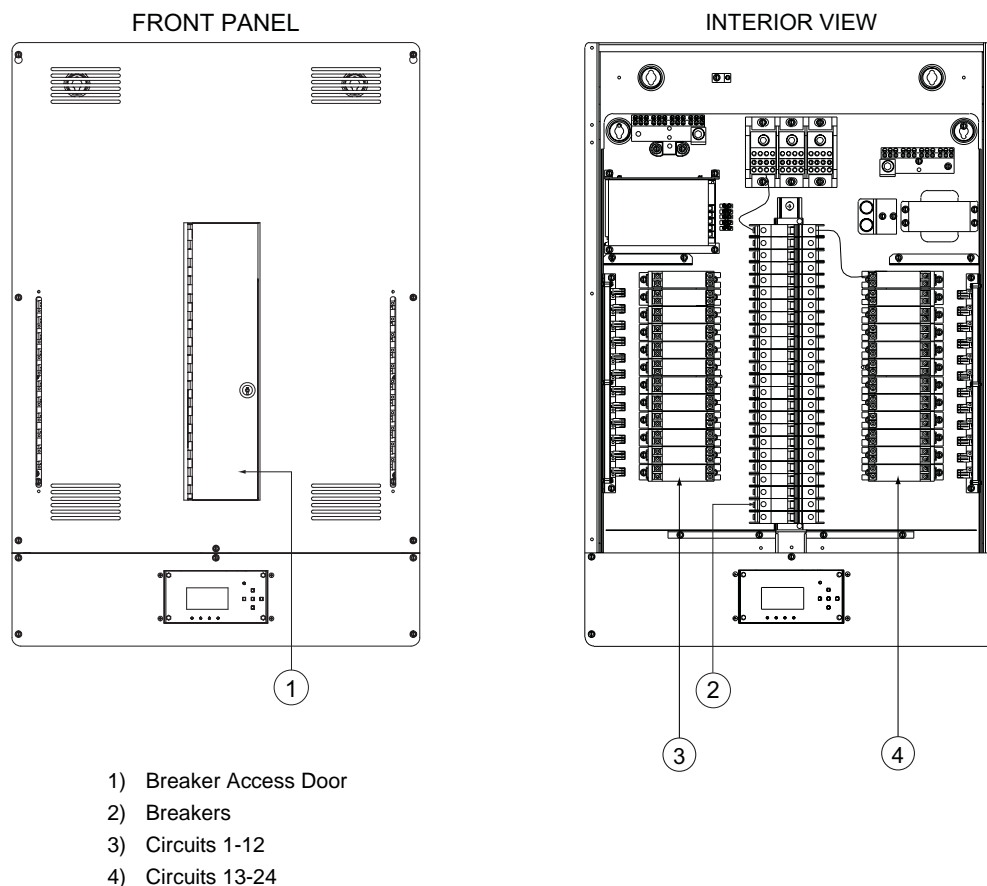

Figure 2: Lighting Control Panel with Internal Circuit Breakers

Note: The 24-Circuit Breaker Panel is shown in this example, however, components are typical for all breaker models.

3. Installation Overview

The following steps are required to successfully install this product:

- 1) Review this document completely before starting the installation.
- 2) Unpack and inspect equipment. Compare the equipment you received with your packing list. If these do not match, contact Strand Lighting Customer Service at 1-214-647-7880.
- 3) Gather tools. Refer to Tools List below.
- 4) Choose an appropriate location for installation. Refer to Locations and Clearances below.
- 5) Plan the wire routings and connection order. Decide where the Feed, Load, and Control wiring will enter the panel(s).
- 6) Remove access panels and knockouts as required for conduit or busway entry. Perform all conduit connections to the panel before it is permanently installed. Be sure to remove all knockout pieces and debris.
- 7) Securely mount the Contact Lighting Control Panel and terminate all Feed, Load, and Control wiring following the directions in this manual. Clean up the work site and Lighting Control Panel(s) for checkout by Strand Lighting Technical Services (see "[Notice To Contractor](#)" on page 35).
- 8) Contact Strand Lighting when Lighting Control Panel(s) is installed and ready for checkout.

4. Tools List

The following is a basic list of tools that may be required for this installation:

- Drill (for mounting holes)
- Wire stripper
- Ratchet and assorted sockets
- Hammer (for removing knockouts)
- Heat shrink tubing (if required)
- Conduit and fittings
- Phillips screwdriver
- Pencil
- Digital voltmeter/RMS
- Small flat screwdriver
- Knife
- Adjustable wrench
- Wire cutter

5. Location and Clearances

When installing this product, the location site **MUST** meet the following requirements:

- Wall must be capable of supporting the weight of the fully loaded panel.
- The panel may be either recess-mounted or surface-mounted.
- Indoor Use Only: The unit **MUST** be installed indoors.
- Dry Locations Only: The unit can only be installed in an "office clean" area that is never exposed to moisture of any kind. Strand Lighting is not responsible for damage to equipment caused by moisture, paint, dust, solvents or cleaning supplies.
- Refer to National Electrical Code® and local codes to determine whether additional requirements must be met.

INSTALLATION

1. Mounting the Panel

To mount panel:

Step 1. Locate a suitable location for mounting the panel. (Refer to "Location and Clearances" on page 7.)

Step 2. Mount panel utilizing pre-punched mounting holes, as indicated in **Figure 3**, as follows:

- a. Remove front cover (if installed).
- b. Ensure that wall is capable of supporting the weight of the lighting control panel.
- c. Mark hole placement on wall.
- d. Using four 1/4" wall-anchor bolts (not included), secure panel in place.

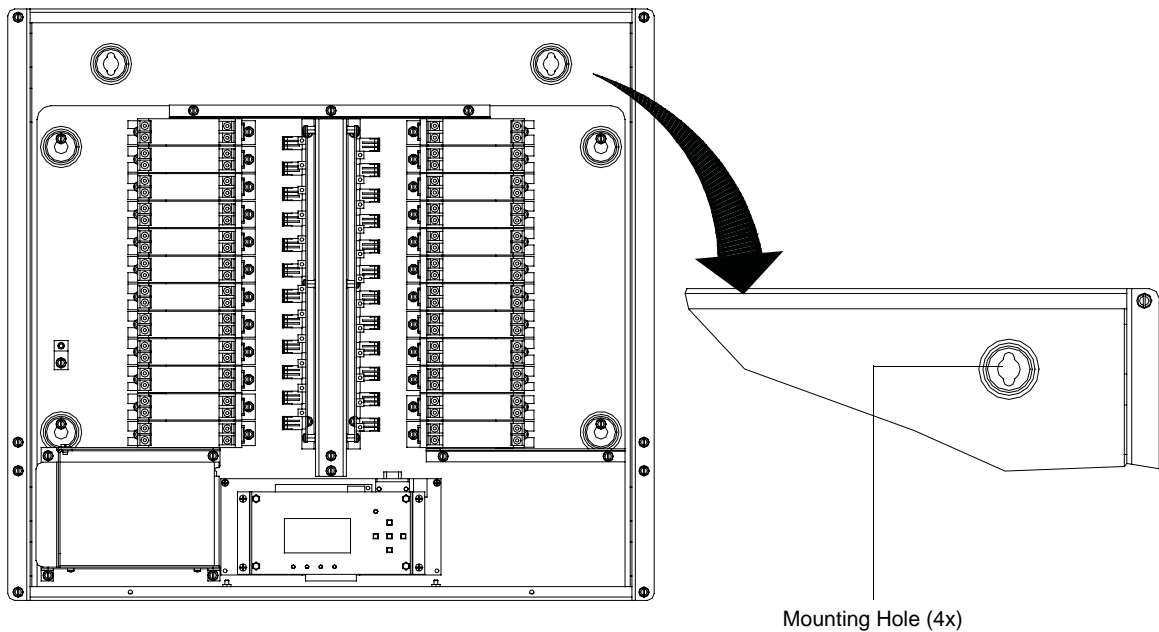

Figure 3: Panel Mounting Holes

Note: The 24-Circuit Panel is shown in this example, however, components are typical for all models.

2. Connecting Line/Load Wiring



WARNING: You must have access to a main circuit breaker or other power disconnect device before installing any wiring. Be sure that power is disconnected by removing fuses or turning the main circuit breaker off before installation. Installing the device with power on may expose you to dangerous voltage and damage the device. A qualified electrician must perform this installation.

WARNING: Refer to National Electrical Code® and local codes for cable specifications. Failure to use proper cable can result in damage to equipment or danger to persons.

CAUTION: Wire openings **MUST** have fittings or lining to protect wires/cables from damage. Use 75° C copper wire only! The use of aluminum wire is not permitted.

To connect line/load wiring:

- Step 1. Install load and line wiring through knockouts. Refer to **Figure 1** on [page 5](#) and **Figure 4** below.
- Step 2. Connect proper grounding (**Figure 4**).
- Step 3. Install low-voltage wiring through knockouts.

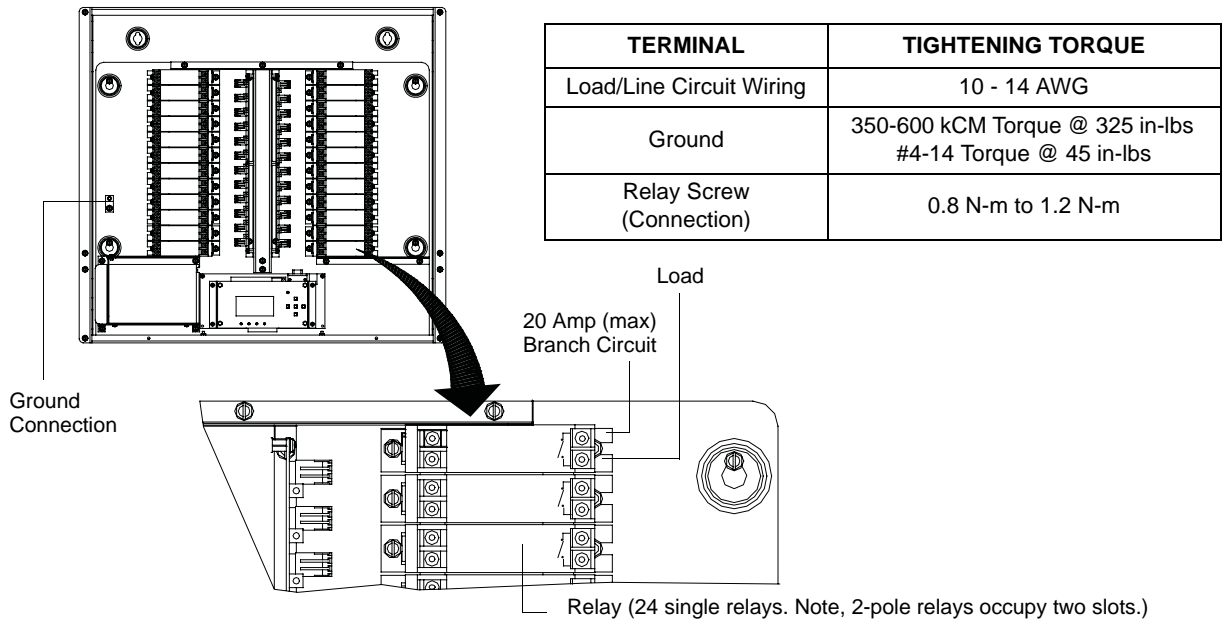

Figure 4: Line/Load Wiring Connections

Note: The 24-Circuit Panel is shown in this example, however, components are typical for all models.

3. Control Wiring

Contact Lighting Control Panels may be controlled by the following methods:

- DMX512
- Vision.net
- Optional ShowNet Ethernet (10/100BaseT)
- Auxiliary inputs: Panic Control or Fire Alarm Signal.
- Local control through Rack Control Module (RCM) processor.

For approved wire types per control method, refer to "Appendix A: Standard Wiring" on page 22.

Each Lighting Control Panel contains a Controller PCB for connection of control wiring. The Controller PCB also contains jumpers for termination of DMX512 signal and connection to Slave panels.

To connect control wiring:

- Step 1. Route control wiring from source to side of Lighting Control Panel.
- Step 2. Remove knockout(s) as required. See **Figure 1** on page 5.
- Step 3. Install conduit fittings or insert lining materials in the knockout opening.
- Step 4. Pull control wiring through prepared openings.



CAUTION: Wire openings must have fittings or linings to protect wire and cable insulation.

- Step 5. Prepare cabling as shown in "Appendix A: Standard Wiring" on page 22.
- Step 6. Connect wiring to appropriate locations on Controller PCB. See **Figure 5**.
- Step 7. Set DMX A Thru termination jumper as required.

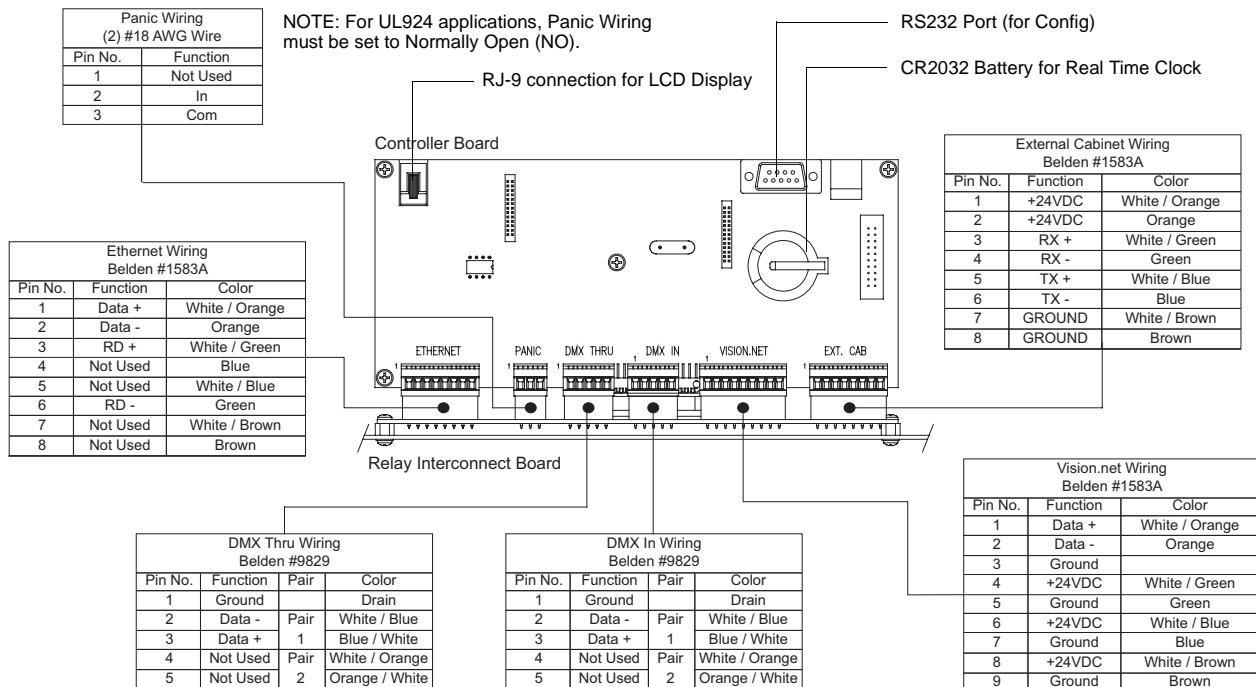

Figure 5: Controller / Relay Interconnect PCB Connections

CONFIGURATION USING RCM LCD MENU

1. Overview

The Contact Lighting Control System can be configured directly at the Rack Control Module (RCM) processor using the built-in LCD Menu or via Vision.net Designer software. For more information on Vision.net Designer, visit the Strand Lighting web site at www.strandlighting.com.

2. Menu Operation

The RCM LCD Menu provides local control for accessing all system status information and for making a limited amount of configuration changes to that particular RCM processor. (If there are multiple RCMs in the system, changes would need to be made at each RCM.)

Upon power up, the LCD Menu will display the Strand Lighting logo followed by the current RCM software version and RCM name. After briefly displaying this information, the MAIN MENU will appear.

Note: To return to the power up screen after boot up, press the [Escape] button.

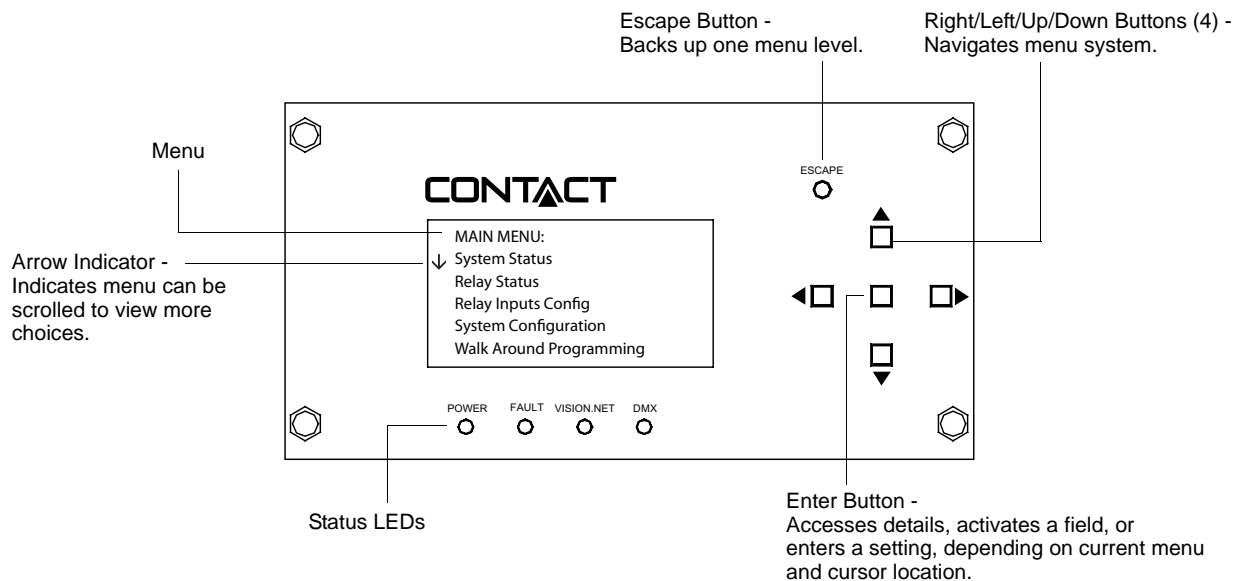

Figure 6: LCD Menu

LED Status Indications:

LED	Condition	Meaning
POWER	Flashing Green	Indicates power is active to the Rack Control Module (RCM) processor.
FAULT	Flashing or Steady Red	Indicates an error condition in the cabinet. If illuminated, remove power to the panel, wait 15 seconds, and re-energize panel. If error condition persists, please contact Strand Lighting Technical Support.
VISION.NET	Illuminating Yellow	Indicates presence of Vision.net control signal. (Not constant. Only flashes when Vision.net is sending data.)
DMX	Illuminating Yellow	Indicates presence of USITT DMX512 control signal. Constant on when DMX512 signal is present.

3. Menu System

To navigate the menus, press the four navigation buttons as required (**Figure 6**). When the desired menu is reached, press [Enter] to display the menu options. Use navigation and [Enter] buttons to view status and configure RCM processor. The menu system consists of several main categories as shown below:

LCD Menu Structure

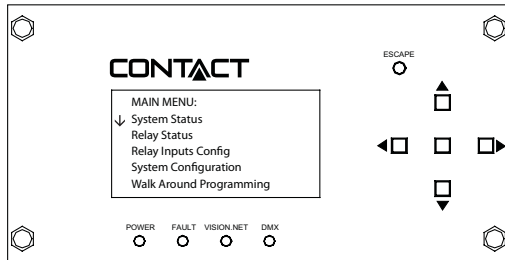

SYSTEM STATUS (status information shown, no user-selectable options)

Sub Menu	Options	Comments
Name	N/A	Displays assigned name of relay panel as programmed by user.
Location	N/A	Displays assigned location of relay panel as programmed by user.
Serial	N/A	Displays relay panel serial number.
Type	N/A	Displays type of relay panel.
Relay Status	N/A	Displays current status of the selected relay as assigned by the user.
Relay Present	N/A	Displays which preset a relay is assigned to.
Relay with Errors	N/A	Displays the number of relays with an error.
Firmware	N/A	Displays Processor's current firmware version as: 86-XXXX vX.XX

RELAY STATUS (status information shown, no user-selectable options)

When first viewing the this menu, the current status of Relay 1 will be displayed. To view the current status of other relays, press the right-arrow button to increment by 1. For example, pressing the right-arrow button will advance to Relay 2, pressing it again will advance to Relay 3, and so on.

Sub Menu	Options	Comments
Relay	N/A	Displays relay name and number as assigned) programmed by user).
Output %	N/A	Displays 0 (off) to 100% (on)
Status	N/A	Displays if Normal or Local control.
Errors	N/A	Displays any relay errors.
Module	N/A	Displays relay rating (2400 W)
Version	N/A	Displays firmware version.

Continued next page

LCD Menu Structure (continued)

Continued from previous page

RELAY INPUTS CONFIG

Sub Menu	Options	Comments
Relay	N/A	Displays selected relay number if assigned.
DMX A	N/A	User defined DMX address for DMX A port.
DMX B (Ethernet)	N/A	User defined DMX address for DMX B port.
Room	N/A	Displays Relay's assigned room number.
Channel	N/A	Displays Relay's assigned channel number.
Flick Warn <i>IMPORTANT! Since some loads, such as HID lamps, cannot be turned off and on quickly, disabling Flick Warn ("No") is recommended for those relays.</i>	Yes or No	Enables (selecting "Yes") or Disables (selecting "No") to flick lights on and off (warning that a timed event is about to occur to turn of the lights). <i>This time is programmed into the Sweep Off event and is normally 5 minutes. Occupants can override the sweep for up to 2 hours. This time is also programmed into the event. The override is done by pressing any button on a keypad.</i>
Parked	Yes or No	Locally overrides all system control.
Trigger Level	1 to 255	Sets signal level for relay to trigger on and off.
DMX A Priority	None / Primary / Fallback	Sets priority level for DMX A (see note below)
DMX B Priority	None / Primary / Fallback	Sets priority level for DMX B (see note below)
Preset Priority	None / Primary / Fallback	Sets priority level for local presets
<p>NOTE: DMX A and DMX B Priority Levels</p> <p>There are three possible priority scenarios with two input sources:</p> <ul style="list-style-type: none"> • Primary vs. Primary - in the this case, the source with the highest level takes precedence (HTP). • Primary vs. Fallback - in this case, the Primary source would take precedence -- unless the Primary source is not present, at which time the Fallback source would take precedence. • Fallback vs. Fallback - in the this case, the source with the highest level takes precedence (HTP), as long as a source is actually present. 		

Continued next page

LCD Menu Structure (continued)

Continued from previous page

SYSTEM CONFIG

Sub Menu	Options	Comments
DMX A	Enabled / Disabled	Enables or disables the DMX A port to accept DMX512 input signals.
DMX B	Ext Config	Enables or disables the DMX B port to accept DMX512 input signals. Only used when a DMX to Ethernet node is installed.
Vision.net Network	Enabled / Disabled	Enables or disables the Vision.net Network port
Vision.net Station ID	Off / 1 thru 255	Sets Vision.net Station ID for the relay panel. If more than one panel is connected to the same Vision.net system, each panel should have a unique ID number.
DMX Hold (hh:mm) (in hours:mins)	None / 0:01 / 0:05 / 0:10 / 0:15 / 1:00 / 2:00 / 4:00 / 12:00 / 24:00 / Forever	Sets the amount of time the dimmer cabinet will keep and hold the last DMX512 levels should connection or signal be lost.
Power-up Preset	None / 1 / 2 / 3 / 4 / 5 / 6 / 7 / 8	Sets what preset the dimmers go to when dimmer cabinet is initially powered
Power-up Hold	Forever / 0:01 / 0:05 / 0:10 / 0:15 / 1:00 / 2:00 / 4:00 / 12:00 / 24:00	Sets the amount of time the dimmers will go and stay at the preset level (if set) when the dimmer cabinet is initially powered.
Preset Clear	None / DMX A / DMX B / DMX A/B / VN A / VN B / VN A/B	Sets how local presets are cleared or overridden - either never or via DMX512 or Vision.net commands
Config Port	Ethernet / RS232	Sets configuration port to Ethernet or RS232 input. Normal setting is Ethernet.
Panic Inputs	Normally Open / Normally Closed	Sets panic inputs to open or closed. Note, for UL924 applications, the panic input must be set to Normally Open.

WALK AROUND PROGRAMMING

Below is a description of this menu and its options. See ["Walk Around Programming Procedures"](#) on page 16 for more information.

Sub Menu	Options	Comments
Assign One Keypad Addr	Room # / Start	Assigns a single keypad to a single address.
Multiple with Same Addr	Room # / Start	Assigns multiple keypads to a specific room.
Multiple with Auto Increment	Room # / Start	In this mode, the relay panel will flash all connected keypads. When a button is pressed on a keypad, a room number is assigned to that keypad. The next button pressed on another keypad will assign the next room number.
Assign Relay to Room	Room # / Start	Assigns a selected relay to a specific room.
Edit Vision.net Presets	Select Room #	Edits Vision.net preset for selected room.
Auto Assign VN Channel	Select Room #	Will automatically assign Vision.net channels to specific relays.

Continued next page

LCD Menu Structure (continued)

Continued from previous page

TIME CLOCK FUNCTIONS

Below is a description of this menu and its options. See ["Time Clock Operation and Programming"](#) on page 18 for more information.

Sub Menu	Options	Comments
View Current Events	Press [Enter] to view (scroll) all programmed events	Allows users to scroll through all programmed events.
Add/Edit Time Clock Events	Refer to "Time Clock Operation and Programming" on page 18 for programming and operation details of this functions.	
Add/Edit Time Clock Action		
Set Time		
Set Date		
Set Location	Latitude / Longitude / Time Zone (UTC - Coordinated Universal Time)	Allows the setting of the relay panel's location using known Latitude and Longitude Coordinates or from a selection of pre-programmed list of cities.
Time Clock	Enable / Disable	Allows the selection of Enabling or Disabling the relay panel's time clock function. NOTE: only one active time clock per system.

SELECT PRESET

Sub Menu	Options	Comments
Select a Preset	None / 1 / 2 / 3 / 4 / 5 / 6 / 7 / 8	Manually selects a preset via the unit's processor (as in testing processor communication and dimmer operation)

LOCAL PRESETS CONFIG

Sub Menu	Options	Comments
Relay	N/A	Displays current relay number
Preset	1 / 2 / 3 / 4 / 5 / 6 / 7 / 8	Selects the preset to be programmed/ assigned to
Fade Rate (min.)	None / 0:01 / 0:05 / 0:10 / 0:15 / 1:00 / 2:00 / 4:00 / 12:00	Selects the fade rate for a preset.
Level (%)	0 to 100% (in 1% increments)	Selects the preset level of the relay to turn on (each relay is individually programmable).
Relay Set	One / All / Capture (Yes / No)* * Next selection is "Capture ALL relays? (Yes / No)	Allows users to set preset to one or all relays (at the same time) or Capture (snapshot) a look from all dimmers

MENU CONFIG

Sub Menu	Options	Comments
Display On (min) (in minutes)	Always (always on) / 1 to 60 minutes (in 1 minute increments)	Sets the amount of time the unit's processor LCD display backlight is on after the last button press
LED ON (MIN)	Always (always on) / 1 to 60 minutes (in 1 minute increments)	Set the amount of time the status LEDs flash during operation. The Power LED normally flashes (as a heartbeat) when set to Always. When the option is set to a specific time, the LED will only flash in the time increment (e.g., every five minutes).
Display Contrast (%)	0 to 100% (in 1% increments)	Sets the contrast level of the LCD Display
Set New Password	#####	Sets the user-defined password.

4. Walk Around Programming Procedures

Walk Around Programming is a simplified keypad addressing system using Vision.net button stations without the need of a computer (Vision.net Designer not required). When a keypad is in its Factory Default Mode, its Room assignment can be configured using the Relay Panel. Its buttons will default to Presets 1 through 6, and OFF (7 button keypad for example). This allows a simple system to be setup using keypads that just send out Preset commands.

IMPORTANT! For a keypad to respond to Walk Around Programming commands it must be in its **Factory Default Mode**.

Setting Keypad to Factory Default Mode

To put a keypad into Factory Default Mode perform the following steps:

- Step 1. Completely disconnect keypad from Vision.net network to power down unit.
- Step 2. Press and hold any button on keypad and reconnect to Vision.net network (powering unit). **Do not release button until told to do so in subsequent step.**
- Step 3. Continue to hold keypad's button until the keypad beeps once, and then twice (keypad is setting all of its parameters to Factory Default settings).
- Step 4. Release keypad button and wait for keypad to beep 4 times (parameters are now initialized).
- Step 5. Press **EVERY** button on keypad (keypad will beep with every button press). *Please note:*
 - This tells the keypad which buttons are available on the keypad. Only those buttons that have been tapped will now be enabled.
 - The keypad will remain in this Factory Test Mode for 30-60 seconds and then return back to Normal (4 more beeps).
 - Removing the keypad from the network and then plugging it back into the network will also restore the keypad back to normal.
- Step 6. The keypad is now ready to be assigned a room by using Walk Around Programming Menus on the relay panel.

IMPORTANT! Once Vision.net Designer has configured a keypad, it will not respond to Walk Around Programming commands. It must be returned to Factory Default Mode.

Assign One Keypad Address

This feature allows a single address to be assigned to a single external keypad.

To assign one keypad with a single address:

- Step 1. At WALK AROUND menu, navigate to "Assign One Keypad Address" and press [Enter] button.
- Step 2. At BUTTON STATION screen, press [Enter] button and then use arrows to select desired Room.
- Step 3. Press [Enter] button to initiate programming mode. A signal will be sent to all connected button stations. Each keypad will beep and/or flash the buttons to indicate that the signal is being received.
- Step 4. Walk to the desired Room where keypad is located. Press any button on the keypad and hold for three seconds. The address is now assigned to that station.

Multiple with Same Address

This feature allows a single address to be assigned to a multiple external keypads.

To assign multiple keypads with a single address:

- Step 1. At WALK AROUND menu, navigate to "Multiple with Same Address" and press [Enter] button.
- Step 2. At BUTTON STATION screen, press [Enter] button and then use arrows to select desired Room.

- Step 3. Press [Enter] button to initiate programming mode. A signal will be sent to all connected button stations. Each keypad will beep and/or flash the buttons to indicate that the signal is being received.
- Step 4. Walk to first Room where a button station is located. Press any button on the station keypad and hold for three seconds. The address is now assigned to that station.
- Step 5. Walk to second Room where a button station is located. Press any button on the station keypad and hold for three seconds. The same address is now assigned to the station.
- Step 6. Continue until all button stations are programmed. At LCD menu, press [Escape] button to stop signal transmission.

Multiple with Auto Increment

This feature allows multiple (incrementing) addresses to be assigned to multiple external keypads.

To assign multiple keypads with distinct addresses:

- Step 1. At WALK AROUND menu, navigate to "Multiple with Auto Increment" and press [Enter] button.
- Step 2. At BUTTON STATION screen, press [Enter] button and then use arrows to select desired Room.
- Step 3. Press [Enter] button to initiate programming mode. A signal will be sent to all connected button stations. Each keypad will beep and/or flash the buttons to indicate that the signal is being received.
- Step 4. Walk to first Room where a button station is located. Press any button on the station keypad and hold for three seconds. The starting address is now assigned to that station, and the address will now increment by 1.

Note: For example, if the starting address is 1, then the system will increment to 2 after the first button station is set, then to 3 after the next station is set, and so on.)

- Step 5. Walk to the next Room where a button station is located. Press any button on the station keypad and hold for three seconds. The new address is assigned to that station.
- Step 6. Continue until all button stations are programmed. At LCD menu, press [Escape] button to stop signal transmission.

Table 1: EDIT EVENT Parameters

<i>Option</i>	<i>Meaning</i>
Name	Name of event as assigned by user.
Type	Event type - AM, PM, ASR (after sunrise), ASS (after sunset)
Time	Actual time of day OR time in relation to sunrise or sunset.
Days	SMTWTFS (Sunday, Monday, Tuesday, Wednesday, Thursday, Friday, Saturday)

Assign Relays to Room

This feature allows panel relays to be assigned to a Room.

To assign a relay (or relays) to a room:

- Step 1. At WALK AROUND menu, navigate to "Assign Relays to Rooms" and press [Enter] button.
- Step 2. At ASSIGN RELAYS screen, press [Enter] button. Use arrows to select desired Room and press [Enter] button.
- Step 3. At front of relay panel, press Relay Manual Switch (or Switches - refer to "[Lighting Control Panel Overview](#)" on page 5 for details) to select desired relays. Relay LED will illuminate green when that relay is selected. Press button again to deselect (the buttons are toggle action).
- Step 4. At menu, press [Enter] button to Save configuration.

Edit Vision.net Presets

This feature allows relays to be configured for 0% (off) or 100% (on) when a Preset is selected via a connected button station.

To program or edit Vision.net Presets:

- Step 1. At WALK AROUND menu, navigate to "Edit Lytemode Presets" and press [Enter] button.
- Step 2. At EDIT VISION.NET PRESETS screen, use arrows to select desired Room, then press [Enter] button.
- Step 3. Use arrows to select desired Preset, then press [Enter] button.
- Step 4. At front of relay panel, press Relay Manual Switches to toggle relay ON or OFF. When a relay is OFF, its green LED will blink. When a relay is ON, its green LED will be solid.*

Note: When the EDIT VISION.NET PRESETS function is active, the LED's will illuminate solid (on) or blinking (off) to indicate current relays assigned to that Room. If a relay is not assigned to that Room, its LED will not be illuminated.

- Step 5. Once all relays are set as desired, press [Enter] button to Save configuration. Next time this Preset is selected at a button station, the relays will follow this saved Preset.

Auto Assign VN (Vision.net) Channels

This feature allows Vision.net channels to be assigned to a Room. For example, if four relays are currently assigned to Room 8, Vision.net channels 1-4 will automatically be assigned to those relays in sequential order.

To assign Vision.net channels:

- Step 1. At WALK AROUND menu, navigate to "Auto Assign VN Channels" and press [Enter] button.
- Step 2. At SET CHANNELS screen, use arrows to select desired Room, then press [Enter] button.
- Step 3. Use arrows to select desired Channel, then press [Enter] button. Vision.net channels will automatically be assigned to relays (this only applies to relays that are currently saved / assigned to that specific Room).
- Step 4. Press [Enter] button to Save configuration.

5. Time Clock Operation and Programming

IMPORTANT! Only one active time clock should be used per system or conflicting commands, undesired operation may occur.

This menu allows setup of the relay panel's Real Time Clock (RTC), along with adding, editing, and viewing time clock Events and Actions. Note that Event scheduling may be done on a daily basis, either at an absolute time, or relative to Sunset and Sunrise.

Note: If the time clock is disabled, the date and time will not show up in the relay panel's main menu screen. Sunrise and Sunset times will alternate on the home screen.

Definitions:

Event - An Event is a programmed / scheduled occurrence with starting and ending times to execute one or more Actions (Example, turn on Preset 1 at 8:00 am and turn them off at 5:00 pm, every Monday through Friday).

Action - An Action is a function within Event. In the example above, the Actions are turn on and turn off loads.

View Current Events

Allows users to select and view a list of programmed time clock Events. Once at this menu, use arrow keys to scroll through all programmed events.

Add/Edit Time Clock Events

This feature allows adding or editing time clock Events. An Event is the time in which the associated Action(s) will take place.

Note: Every Time Clock Event must have at least one associated Action.

To add or edit an Event:

- Step 1. At CLOCK CONFIG menu, navigate to Add/Edit Time Clock Events and press [Enter] button.
- Step 2. At EDIT EVENT screen, configure event options (Name, Type, Time, and Days) as desired. See [EDIT EVENT Parameters](#) for more information.
- Step 3. To Save the new or edited event, navigate to Store This Event and press [Enter] button.

Add/Edit Time Clock Actions

This feature allows adding or editing time clock Actions. An Action is associated with an Event (see Event definition above).

To Add an Action:

- Step 1. At CLOCK CONFIG menu, navigate to Add/Edit Time Clock Events and press [Enter] button.
- Step 2. At ADD NEW ACTION screen, configure action options (Preset, Room, Fade Rate, etc.) as desired.
- Step 3. To Save the new action, navigate to Save This Action and press [Enter] button.

Action types:

- 1) Preset - recalls a Preset to a room.
- 2) Toggle On - Toggle on a designated channel and room.
- 3) Toggle Off - Toggle off a designated channel and room.
- 4) Vision.net Scene - Triggers a network-wide Vision.net Scene.
- 5) Sweep Room - Sweeps a room off. A "Sweep Room" is the change of the room preset to "Preset X" (after hours operation assigned preset).
- 6) End Sweep - Cancels sweep to return room to normal operation. Important note, without an End Sweep action, Sweep Room action will remain active.
- 7) None (delete) - Deletes current action.

To Edit an Action:

- Step 1. At CLOCK CONFIG menu, navigate to Add/Edit Time Clock Actions and press [Enter] button.
- Step 2. At first EDIT ACTIONS screen (List of Events), select the Event in which the Action is associated with, and press [Enter] button.
- Step 3. At next screen (Associated Actions), make desired changes. To Save changes, navigate to Add New Action and press [Enter] button.

Set Time

This feature allows the setting of the time in the Time Clock.

To set Time:

- Step 1. At CLOCK CONFIG menu, navigate to Set Time and press [Enter] button.
- Step 2. To begin editing Time, press [Enter] button. The first parameter (hours) will be highlighted.
- Step 3. Use UP and DOWN arrows to change parameters. Use LEFT and RIGHT arrow button to navigate between parameters (hours / minutes / seconds).
- Step 4. When all edits to Set Time are complete, press [Enter] button to save configuration. NOTE: Pressing [Escape] button will go to previous menu and changes will not be saved.

Set Date

This feature allows the setting of the date in the Time Clock.

To set Date:

- Step 1. At CLOCK CONFIG menu, navigate to Set Date and press [Enter] button.

- Step 2. To begin editing Date, press [Enter] button. The first parameter (month) will be highlighted.
- Step 3. Use UP and DOWN arrows to change parameters. Use LEFT and RIGHT arrow button to navigate between parameters (month / day / year).
- Step 4. When all edits to Set Date are complete, press [Enter] button to save configuration. NOTE: Pressing [Escape] button will go to previous menu and changes will not be saved.

Set Location

This feature sets the location for the relay panel. For Sunrise and Sunset timing operation, Latitude and Longitude must be configured.

To set the location:

- Step 1. At CLOCK CONFIG menu, navigate to Set Location and press [Enter] button.
- Step 2. At SET LOCATION screen, navigate to Choose City From List and press [Enter] button.
- Step 3. At next screen, choose your city* and press [Enter] button. The location information will be set for the real time clock.

Note: *If your city is not listed, chose the city closest to your location. You may also manually set the Latitude, Longitude and Time Zone, if desired.

EMERGENCY LIGHTING OPERATION (UL924)

1. Overview

When required, the Contact Low Voltage Lighting Control Panel may be used to energize emergency lighting circuits in the event of a loss of power. Contact Panels may be custom configured at the factory with special software and hardware to allow the unit to comply with UL924 Electronic Bypass. When configured in this mode, the Contact Panel allows select circuits to be energized at 100% output upon activation by a control signal. Circuits not identified as emergency may be locked "Off" or can "Ignore" the emergency state and still respond to local controls.

When Contact Panels are used as part of an emergency lighting control system, feed power supplied to the Contact Panel must be switched by a certified (National Recognized Testing Laboratory) Transfer Device.

To trigger the Contact Panel to enter the emergency mode, a control signal (Contact-Closure, open) must be provided to the panel, and connected to the Panic #1 input, located on the Connect PCB. Strand Lighting recommends the use of a Phase Loss Sense Panel to monitor normal power and provide the control signal to the Contact Panel in the event of a disruption of any phase of the normal power feed.

When the Contact Panel is in an active emergency mode, the LCD display will read EMERGENCY MODE ACTIVE and the display backlight will flash.

IMPORTANT! UL924 operation applies only to Contact Panels which have been configured at the factory for Emergency Lighting Operation. If a previously installed Contact Panel is required to operate emergency lighting and needs to be updated in the field by a certified Strand Lighting Technician, please contact Strand Lighting Technical Support at 1-214-647-7880.

APPENDIX A: STANDARD WIRING

1. DMX512

DMX512 Terminal	XLR Pin Name	WE Color Code (e.g., Belden #8132)	IECA Color Code	Belden Standard Color Code	CATEGORY 5e Color Code
GND	1	Drain Wire (Shield)	Drain (Shield)	Drain (Shield)	Brown White/Brown
DMX -	2	White w/ Blue	Black	Black (of Red pair)	Orange
DMX +	3	Blue w/ White	White	Red	White/Orange
AUX -	4	White w/ Orange	Red	Black (of White pair)	Green
AUX +	5	Orange w/ White	Green	White	Green/White

Contractor is Responsible for All Terminations

- 1) Only approved EIA-485 cable types may be used. Approved types include:
Belden #9829TMB Proplex #PC224T
An acceptable plenum rated cable is: Belden #89729
- 2) Category 5e cable may be used for DMX512. Approved types include: Belden #1583A and Belden #1585A (Plenum).
- 3) Cable MUST be terminated exactly as shown here.
- 4) DMX512 cable runs MUST be routed in a "Daisy-Chain" configuration as shown in your drawing set, if provided. DO NOT convert these cables to home runs.
- 5) DMX512 cable runs should all be in metal conduit. Runs in exposed areas must be in metal conduit. Maximum cable run should not exceed 1000 feet.

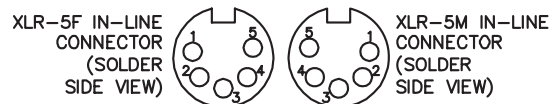
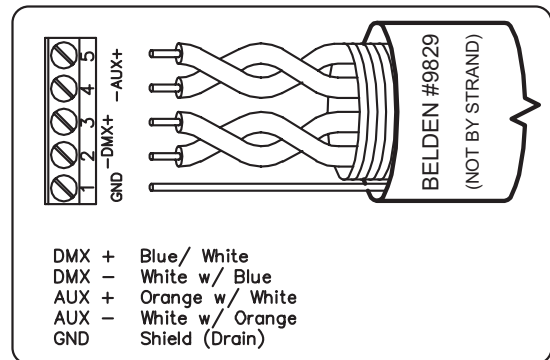

Note: add heat shrink as needed.

2. Vision.net Networks (RS485 over CAT5e)

Pin Number	Signal Name	Shielded Cat5e Wire Color (Belden #1624 R or P)
1	Data +	White w/ Orange
2	Data -	Orange
3	Ground	Shield Ground
4	+24 VDC	White w/ Green
5	Signal GND	Green
6	+24 VDC	White w/ Blue
7	Signal GND	Blue
8	+24 VDC	White w/ Brown
9	Signal GND	Brown

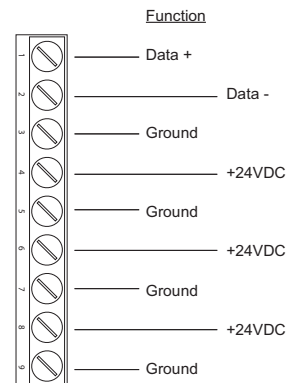

Contractor is Responsible for All Terminations

- 1) Only approved cable types may be used. Approved types include: Belden #1583A and Belden #1585A

- 2) Cable MUST be terminated exactly as shown here. Total length of cable in each Vision.net Network LAN Wiring must NOT exceed 1000 feet per home run / daisy-chain to powered source.
- 3) Cable runs should be routed in a "Daisy-Chain" configuration as shown in your drawing set, if provided. DO NOT convert these cables to home runs.
- 4) Maximum station quantity subject to power supply and system requirements. Please consult factory for specific information.

3. Termination of Shielded Cable

Dimension	Name	Minimum	Maximum for Terminal	Maximum for LXR (In-Line)
A	Remove Cable Jacket	1" (25.4mm)	2-1/4" (60mm)	1-1/4" (31.8mm)
B	Drain Wire Heatshrink	Dim 'A' - 1/8" (3.2mm)	-	-

To terminate shielded cable:

- Step 1. Strip off specified length of outer jacket.
- Step 2. Cut shield (foil or braid) flush to outer jacket. **DO NOT** cut drain wire.
- Step 3. Fit specified length of 1/16" heat shrink tubing over the drain wire.

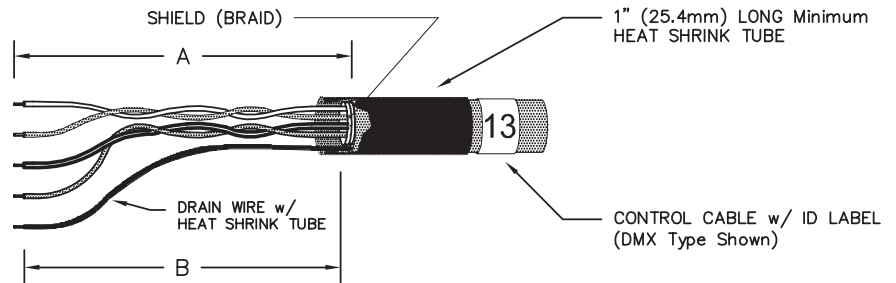

- Step 4. For solder connections, fit a 1/2" length of 1/16" heat shrink tubing over each conductor.
- Step 5. Fit a 1" length of 3/8" heat shrink tubing over the entire cable. Position it so that 3/4" of its length is over the cable jacketing, and 1/4" of its length is over the loose conductors.
- Step 6. Strip 1/8" inch of the insulation from each of the conductors.
- Step 7. Terminate the conductors on the terminal block, or solder the terminals as specified.
- Step 8. For solder connections, shrink the individual 1/2" lengths of heat shrink tubing over the solder terminals.
- Step 9. Shrink the remaining heat shrink tubing.
- Step 10. Apply the appropriate ID label to the cable at the end of the outer heat shrink tubing.

4. Termination of Ethernet Cable

Ethernet Wiring Belden #1583A		
Pin No.	Function	Color
1	Data +	White / Orange
2	Data -	Orange
3	RD +	White / Green
4	Not Used	Blue
5	Not Used	White / Blue
6	RD -	Green
7	Not Used	White / Brown
8	Not Used	Brown

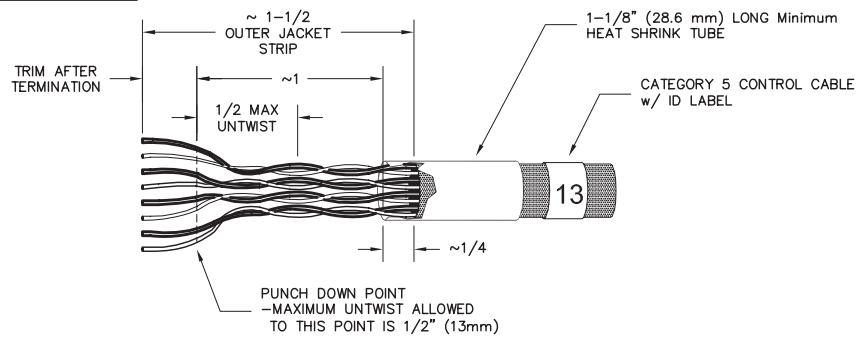

Cable Type (10/100 Base-T Ethernet)	Description
Belden #1583A or equal Nominal O.D. 0.214" (5.54 mm)	CATEGORY 5e: Non-plenum rated 4-Unshielded Twisted Pairs (UTP) #24 AWG
Belden #1585A or equal Nominal O.D. 0.206" (5.23 mm)	CATEGORY 5e: Plenum rated 4-Unshielded Twisted Pairs (UTP) #24 AWG

To terminate Ethernet cable:

- Step 1. Strip off outer jacket - approximately 1-1/2" (37.6mm)
- Step 2. Fit a piece of 1-1/8" (28.6mm) long heat shrink tubing over the cable extending out 1/4" (8.25mm) from outer jacket.
- Step 3. Terminate approximately 1/2" (12.2mm) from end of conductors on Type 110 punch down block or connector per schedule (T568B)
 - Maximum untwist of conductors to terminations is 1/2" (12.2mm)
 - Trim excess leads.
- Step 4. Shrink tubing and add appropriate ID label to the cable at the end of the heatshrink tubing.

System topology and labeling should follow TIA/EIA-568 and TIA/EIA-606 as applicable and guidelines in ESTA's Recommended Practice For Ethernet Cabling Systems in Entertainment Lighting Applications and Supplement.

Per TIA/EIA-568, Maximum length of any horizontal cable run (i.e. between Ethernet RJ-45 receptacle (work area) and Patch Panel) is 90 meters; Maximum length of any CATEGORY 5e cables at the Ethernet RJ-45 receptacle (work area) is 3 meters.

Ethernet equipment (e.g. Patch Panels, Hubs or Switches) should be maintained in an environment of 18°-24° C (64° - 75° F) and 30% - 55% relative humidity per TIA/EIA-569-A.

Maximum length of any segment (cable run - including device cables - between Hub or Switch and Node) is 90 meters. Maximum network diameter (distance between any two Nodes) is 180 meters.

5. Master/Slave Wiring

Pin Number	Signal Name	Un-Shielded CATEGORY 5e Wire Color
1	+ 24 VDC	White w/ Orange
2	+24 VDC	Orange
3	+ RX	White w/ Green
4	- RX	Green
5	+ TX	White w/ Blue
6	- TX	Blue
7	GND	White w/ Brown
8	GND	Brown

Contractor is Responsible for All Terminations

- 1) Only approved cable types may be used. Approved types include: CAT5e or Cat 6 UTP
- 2) Cable MUST be terminated exactly as shown here. Total length of cable in Master/Slave wiring MUST NOT exceed 1000 feet.
- 3) Cable runs MUST be routed in a "Daisy-Chain" configuration as shown in your drawing set, if provided.
- 4) Total number of dimmers (Dual Dimmer Modules = 2 dimmers; Quad Dimmer Modules = 4 dimmers) in Master/Slave wiring MUST NOT exceed 96 total dimmers.

6. Panic Input

Pin Number	Signal Name
1	<i>Not Used</i>
2	IN
3	COM

Contractor is Responsible for All Terminations:

- 1) To be used with PANIC INPUT: Fire Alarm Input or Panic Input Closure.
- 2) To be used with Dry Contact Input only.

IMPORTANT! If the Contact Panel is UL924 enabled, the input must be to Normally Open in the System Configuration.

APPENDIX B: SPECIFICATIONS

1. 12-Circuit Relay Panel (76910)

- Number of Circuits: 12 (Individually replaceable 20A latching relays)
- Relay Types & Ratings:
 - Type 1 - 20A High-Performance Single Pole Latching 120, 230, 277, 347VAC, 50-60Hz, 1.5HP @ 277VAC. Utilizes 1 Contact relay panelboard space.
 - Type 2 - 20A High-Performance Double Pole Latching 208, 480V 50-60Hz. Utilizes 2 Contact relay panelboard spaces.
- AIC Rating: 14,000AIC @ 277VAC
- Load Types: Incandescent (Tungsten, Halogen), Magnetic Low-Voltage, Electronic Low-Voltage, Neon, Non-Dim Fluorescent, HID, LED
- Control via: Internal Astronomical Timeclock, Vision.net Control Stations, Vision.net Occupancy Sensors, Vision.net Photocells, DMX512, ShowNet
- Operating Voltage: Mix 120VAC, 277VAC and 347VAC (requires optional Voltage Barrier Kit)
- Operating Temp: -10° to 60° C (-15° to 140° F)
- Operating Humidity: 10% to 90% (Non-condensing)
- Mounting: Surface or Recessed
- Enclosure: NEMA Type 1
- Compliance: CSA listed to UL508 and UL924

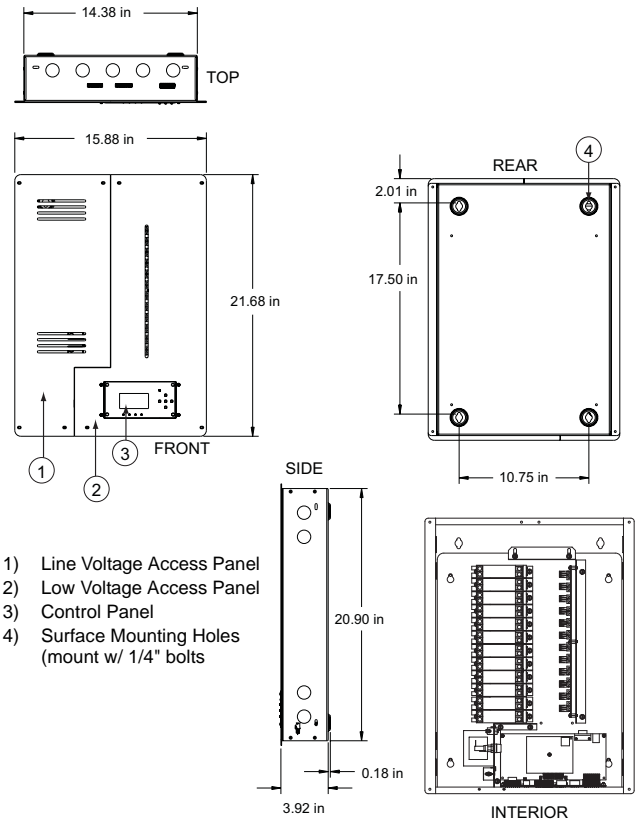

2. 24-Circuit Relay Panel (76911)

Number of Circuits: 24 (Individually replaceable 20A latching relays)

Relay Types & Ratings: Type 1- 20A High-Performance Single Pole Latching 120, 230, 277, 347VAC, 50-60Hz, 1.5HP @ 277VAC. Utilizes 1 Contact relay panelboard space.

Type 2 - 20A High-Performance Double Pole Latching 208, 480V 50-60Hz. Utilizes 2 Contact relay panelboard spaces.

AIC Rating: 14,000AIC @ 277VAC

Load Types: Incandescent (Tungsten, Halogen), Magnetic Low-Voltage, Electronic Low-Voltage, Neon, Non-Dim Fluorescent, HID, LED

Control via: Internal Astronomical Timeclock, Vision.net Control Stations, Vision.net Occupancy Sensors, Vision.net Photocells, DMX512, ShowNet

Operating Voltage: Mix 120VAC, 277VAC and 347VAC (requires optional Voltage Barrier Kit)

Operating Temp: -10° to 60° C (-15° to 140° F)

Operating Humidity: 10% to 90% (Non-condensing)

Mounting: Surface or Recessed

Enclosure: NEMA Type 1

Compliance: CSA listed to UL508 and UL924

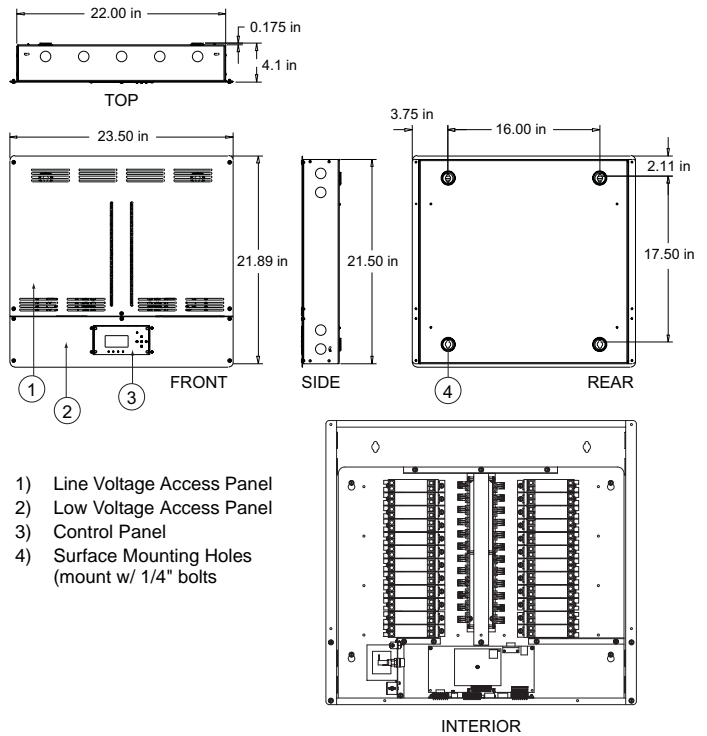

3. 36-Circuit Relay Panel (76912)

Number of Circuits: 36 (Individually replaceable 20A latching relays)

Relay Types & Ratings: Type 1- 20A High-Performance Single Pole Latching 120, 230, 277, 347VAC, 50-60Hz, 1.5HP @ 277VAC. Utilizes 1 Contact relay panelboard space.

Type 2 - 20A High-Performance Double Pole Latching 208, 480V 50-60Hz. Utilizes 2 Contact relay panelboard spaces.

AIC Rating: 14,000AIC @ 277VAC

Load Types: Incandescent (Tungsten, Halogen), Magnetic Low-Voltage, Electronic Low-Voltage, Neon, Non-Dim Fluorescent, HID, LED

Control via: Internal Astronomical Timeclock, Vision.net Control Stations, Vision.net Occupancy Sensors, Vision.net Photocells, DMX512, ShowNet

Operating Voltage: Mix 120VAC, 277VAC and 347VAC (requires optional Voltage Barrier Kit)

Operating Temp: -10° to 60° C (-15° to 140° F)

Operating Humidity: 10% to 90% (Non-condensing)

Mounting: Surface or Recessed

Enclosure: NEMA Type 1

Compliance: CSA listed to UL508 and UL924

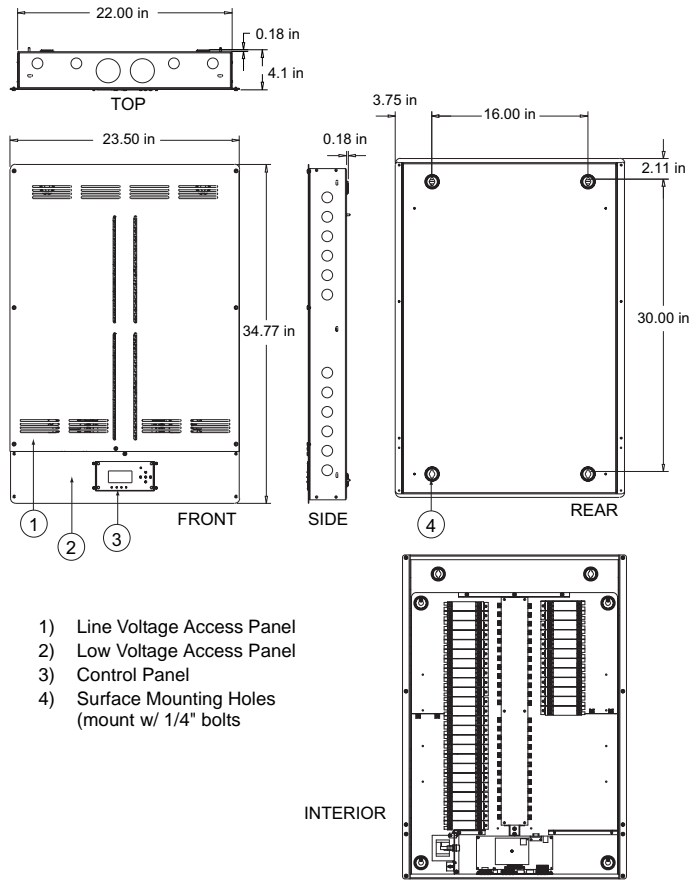

4. 48-Circuit Relay Panel (76913)

Number of Circuits: 48 (Individually replaceable 20A latching relays)

Relay Types & Ratings: Type 1- 20A High-Performance Single Pole Latching 120, 230, 277, 347VAC, 50-60Hz, 1.5HP @ 277VAC. Utilizes 1 Contact relay panelboard space.
 Type 2 - 20A High-Performance Double Pole Latching 208, 480V 50-60Hz. Utilizes 2 Contact relay panelboard spaces.

AIC Rating: 14,000AIC @ 277VAC

Load Types: Incandescent (Tungsten, Halogen), Magnetic Low-Voltage, Electronic Low-Voltage, Neon, Non-Dim Fluorescent, HID, LED

Control via: Internal Astronomical Timeclock, Vision.net Control Stations, Vision.net Occupancy Sensors, Vision.net Photocells, DMX512, ShowNet

Operating Voltage: Mix 120VAC, 277VAC and 347VAC (requires optional Voltage Barrier Kit)

Operating Temp: -10° to 60° C (-15° to 140° F)

Operating Humidity: 10% to 90% (Non-condensing)

Mounting: Surface or Recessed

Enclosure: NEMA Type 1

Compliance: CSA listed to UL508 and UL924

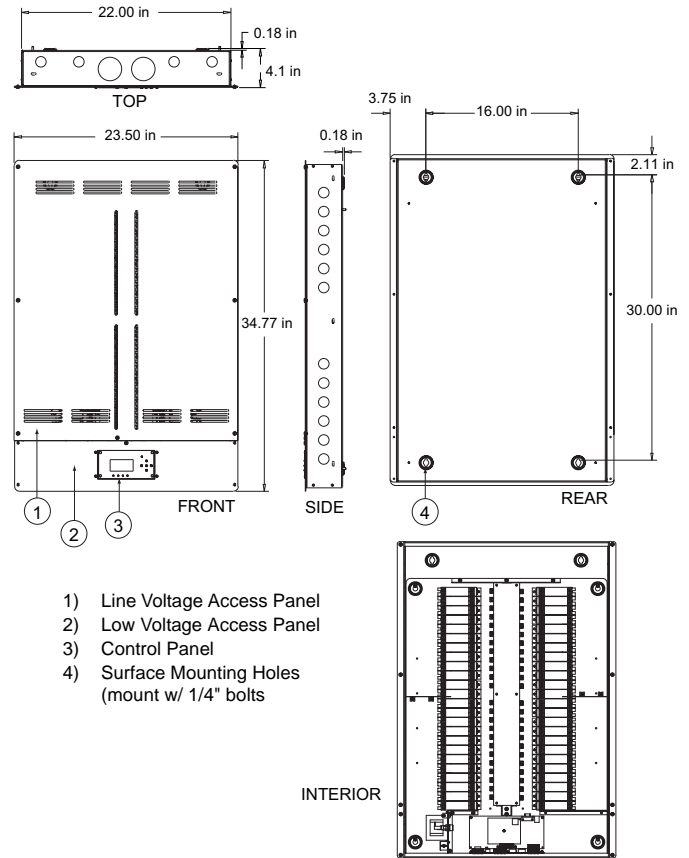

5. 24-Way Relay Insert Panel w/ Breakers (76921C/76931C)

Number of Circuits:	24 (Individually replaceable 20A latching relays)
Relay Types & Ratings:	<p>Type 1- 20A High-Performance Single Pole Latching 120, 230, 277, 347VAC, 50-60Hz, 1.5HP @ 277VAC. Utilizes 1 Contact relay panelboard space.</p> <p>Type 2 - 20A High-Performance Double Pole Latching 208, 480V 50-60Hz. Utilizes 2 Contact relay panelboard spaces.</p>
Circuit Breakers:	Internal branch, 120V Internal branch, 277V
AIC Rating:	14,000AIC @ 277VAC
Load Types:	Incandescent (Tungsten, Halogen), Magnetic Low-Voltage, Electronic Low-Voltage, Neon, Non-Dim Fluorescent, HID, LED
Control via:	Internal Astronomical Timeclock, Vision.net Control Stations, Vision.net Occupancy Sensors, Vision.net Photocells, DMX512, ShowNet
Operating Voltage:	120VAC or 277VAC
Operating Temp:	-10° to 60° C (-15° to 140° F)
Operating Humidity:	10% to 90% (Non-condensing)
Mounting:	Surface or Recessed
Enclosure:	NEMA Type 1
Compliance:	CSA listed to UL508 and UL924

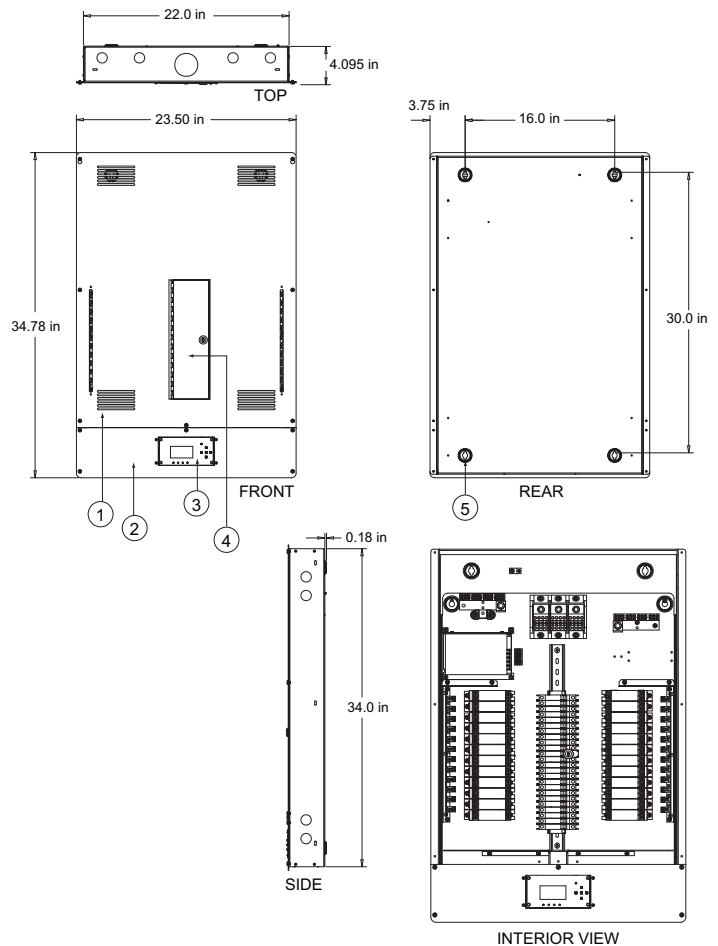

- 1) Line Voltage Access Panel
- 2) Low Voltage Access Panel
- 3) Control Panel
- 4) Breaker Access
- 5) Surface Mounting Holes (mount w/ 1/4" bolts)

6. 36-Way Relay Insert Panel with Circuit Breakers (76922C/76932C)

- Number of Circuits: 36 (Individually replaceable 20A latching relays)
- Relay Types & Ratings: Type 1- 20A High-Performance Single Pole Latching 120, 230, 277, 347VAC, 50-60Hz, 1.5HP @ 277VAC. Utilizes 1 Contact relay panelboard space.
Type 2 - 20A High-Performance Double Pole Latching 208, 480V 50-60Hz. Utilizes 2 Contact relay panelboard spaces.
- Circuit Breakers: Internal branch, 120V
Internal branch, 277V
- AIC Rating: 14,000AIC @ 277VAC
- Load Types: Incandescent (Tungsten, Halogen), Magnetic Low-Voltage, Electronic Low-Voltage, Neon, Non-Dim Fluorescent, HID, LED
- Control via: Internal Astronomical Timeclock, Vision.net Control Stations, Vision.net Occupancy Sensors, Vision.net Photocells, DMX512, ShowNet
- Operating Voltage: 120VAC or 277VAC
- Operating Temp: -10° to 60° C (-15° to 140° F)
- Operating Humidity: 10% to 90% (Non-condensing)
- Mounting: Surface or Recessed
- Enclosure: NEMA Type 1
- Compliance: CSA listed to UL508 and UL924

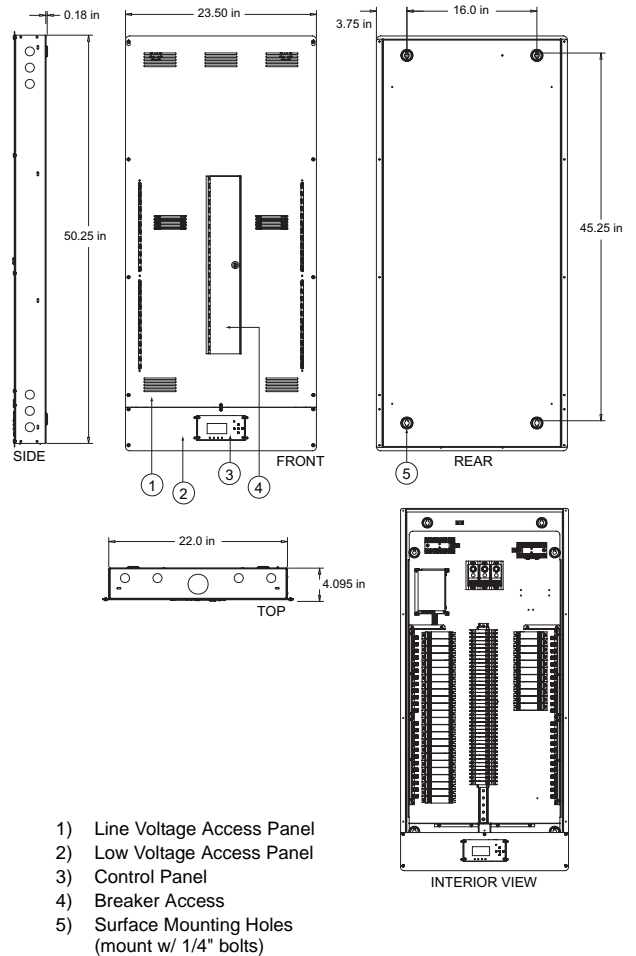

7. 42-Way Relay Insert Panel with Circuit Breakers (76923C/76933C)

Number of Circuits:	42 (Individually replaceable 20A latching relays)
Relay Types & Ratings:	<p>Type 1 - 20A High-Performance Single Pole Latching 120, 230, 277, 347VAC, 50-60Hz, 1.5HP @ 277VAC. Utilizes 1 Contact relay panelboard space.</p> <p>Type 2 - 20A High-Performance Double Pole Latching 208, 480V 50-60Hz. Utilizes 2 Contact relay panelboard spaces.</p>
Circuit Breakers:	Internal branch, 120V Internal branch, 277V
AIC Rating:	14,000AIC @ 277VAC
Load Types:	Incandescent (Tungsten, Halogen), Magnetic Low-Voltage, Electronic Low-Voltage, Neon, Non-Dim Fluorescent, HID, LED
Control via:	Internal Astronomical Timeclock, Vision.net Control Stations, Vision.net Occupancy Sensors, Vision.net Photocells, DMX512, ShowNet
Operating Voltage:	120VAC or 277VAC
Operating Temp:	-10° to 60° C (-15° to 140° F)
Operating Humidity:	10% to 90% (Non-condensing)
Mounting:	Surface or Recessed
Enclosure:	NEMA Type 1
Compliance:	CSA listed to UL508 and UL924

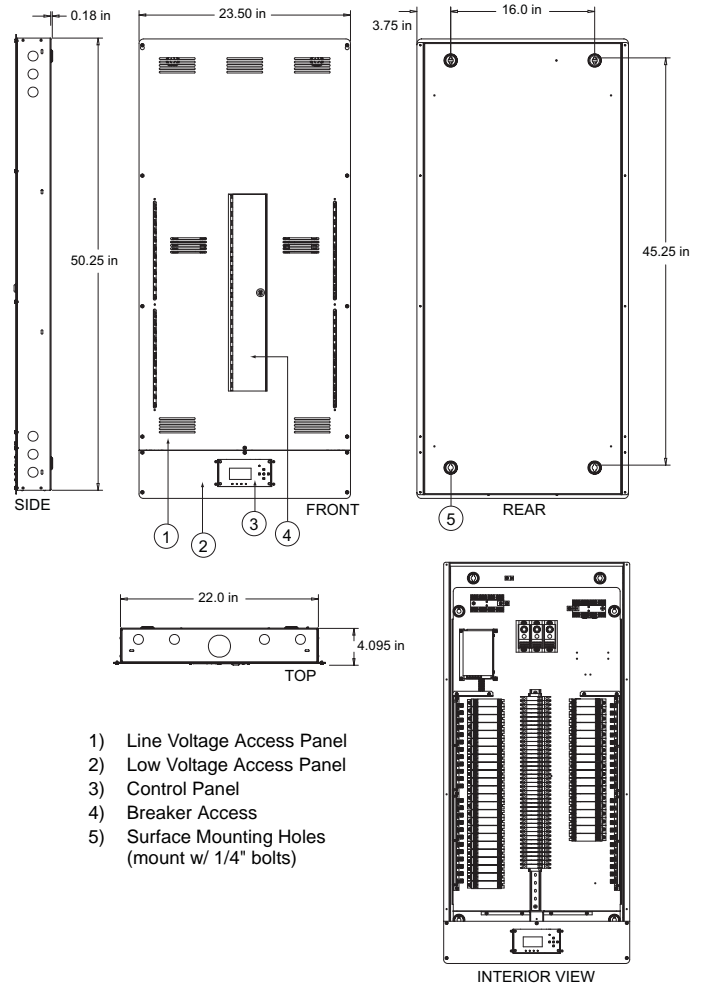

CATALOG NUMBER REFERENCE

1. Contact Panels and Enclosures (Rough-In Boxes)

Relay Panel Inserts – individually fed (1), (3)

Catalog#	Description
76910	Relay Insert Panel, 12-way
76911	Relay Insert Panel, 24-way
76912	Relay Insert Panel, 36-way
76913	Relay Insert Panel, 48-way

Relay Panel Power Inserts with 3-Phase Input and Breakers for 120V Power Supplies (1), (2), (3)

Catalog#	Description
76921C	Relay Insert Panel w/ Breakers, 24-way
76922C	Relay Insert Panel w/ Breakers, 36-way
76923C	Relay Insert Panel w/ Breakers, 42-way

Relay Panel Power Inserts with 3-Phase Input for 277V Power Supplies (1), (2), (3)

Catalog#	Description
76931C	Relay Insert Panel w/ Breakers, 24-way
76932C	Relay Insert Panel w/ Breakers, 36-way
76933C	Relay Insert Panel w/ Breakers, 42-way

Contact Relay Panel Enclosures

Catalog#	Description
CONBOX-1	Enclosure for use with 76910 insert
CONBOX-2	Enclosure for use with 76911 insert
CONBOX-3	Enclosure for use with 76912 / 76913 / 76921C / 76931C inserts
CONBOX-4	Enclosure for use with 76922C / 76923C / 76932C / 76933C inserts

Notes:

- 1) When ordering, specify control options and relay types (number of 1 pole or 2 pole). Note, 2-pole relays occupy (and count as) two relay slots.
- 2) Panels with circuit breakers come with 3-phase mains lugs for power input.
- 3) Panel inserts only. When ordering, specify relay panel enclosure. See Contact Relay Panel Enclosures for required enclosure type.

Note: For Contact Relay Panel options and accessories, refer to "[Contact Options and Accessories](#)" on page 34.

2. Contact Options and Accessories

Control Options

Catalog#	Description
76960	Master Control Option
76961	Auxiliary Control Option (operates with a master panel)
74161	Ethernet Control Module
76924	UL 924 Kit
76990	Barrier Kit

Relay Options

Catalog#	Description
76991	Relay, 1-pole
76992	Relay, 2-pole (occupies two slots)

347V Power Supply Option

Catalog#	Description
76951	277/347V Power Supply for control electronics

Circuit Breaker Options

Catalog#	Description
76966	Circuit Breaker, 1-pole, 20A, 120V
76967	Circuit Breaker, 2-pole, 20A, 120V
76969	Circuit Breaker, 1-pole, 20A, 277V

NOTICE TO CONTRACTOR

1. Technical Services Checkout Procedure



DO NOT APPLY POWER TO THE LIGHTING CONTROL SYSTEM!

No part of this system may be energized or operated until the installation has been approved by a Strand Lighting Technical Services Representative. Violation of this Requirement may damage components and therefore constitute misuse under standard warranty terms. Such misuse may relieve Strand Lighting of any and all further obligations under the terms of this warranty.

Equipment MUST be installed per the Strand Lighting drawings.

All installation and wire terminations MUST be completed per the Strand Lighting drawings prior to the arrival of the Technical Services Representative:

- 1) Input power must be connected to the system, but not energized.
- 2) All loads must be connected and all lighting instruments must be lamped.
- 3) All control wiring must be installed and terminated - including DMX512, Ethernet and Vision.net.
- 4) All equipment, including controllers, accessories, keys, cables and manuals must be in place.
- 5) Personnel for training (i.e. the users), as well as any other personnel required by contract and/or specification must be available for training at the completion of the Checkout and Energizing.
- 6) An owner (or authorized representative), as well as any other personnel required by contract and/or specification will be present to accept the system.

The Technical Services Representative will only be able to:

- Ensure that the system is properly installed and functions correctly, including troubleshooting and providing guidance to the contractor to correct any problems.
- Train personnel in the operation of the Lighting Control System.

The Technical Services Representative will not be able to:

- Install equipment or make electrical connections required of the installing contractor, including DMX512, Ethernet, Vision.net, and/or any other connections that require a licensed electrician.
- Return to instruct any personnel who missed the original training session.

If the above requirements have not been met, the Technical Services Representative will be required to leave the job site. Return trips to complete the Technical Services Checkout require a separate Purchase Order and will be invoiced at the cost of travel (including per diem and travel time door-to-door), hourly labor, and a minimum daily on-site charge. Rescheduling will require 3 weeks notice, subject to Technical Services Representative availability.

Please feel free to contact Strand Lighting Technical Support (1-214-647-7880) should there be any questions regarding the installation of the equipment or requirements regarding the Technical Services Checkout.

When all requirements have been met and the system is ready for inspection, please complete a *Field Service/Commissioning Request Form* (available in Adobe PDF format). This form is available in the Support Section of the Strand Lighting web site (www.strandlighting.com) or from Strand Lighting Technical Support.

Notes

Notes

PHILIPS

Strand Lighting

Strand Lighting
Dallas
10911 Petal Street
Dallas, TX 75238
Tel: 214-647-7880
Fax: 214-647-8031

Strand Lighting
New York
267 5th Ave, 4th Floor
New York, NY 10016
Tel: 212-213-8219
Fax: 212-532-2593

Strand Lighting Asia Limited
Unit C, 14/F, Roxy Industrial Centre
No. 41-49 Kwai Cheong Road
Kwai Chung, N.T., Hong Kong
Tel: +852 2796 9786
Fax: +852 2798 6545

Strand Selecon
Auckland
19-21 Kawana Street
Northcote, Auckland 0627
New Zealand
Tel: +64 9 481 0100
Fax: +64 9 481 0101

Strand Lighting
Europe
Marssteden 152
Enschede 7547 TD
The Netherlands
Tel: +31 53 4500424
Fax: +31 53 4500425

www.strandlighting.com

Part No: 2-450330-010