

# PHILIPS

## PerfectBeam gen.2 Framing Projector

ST512T

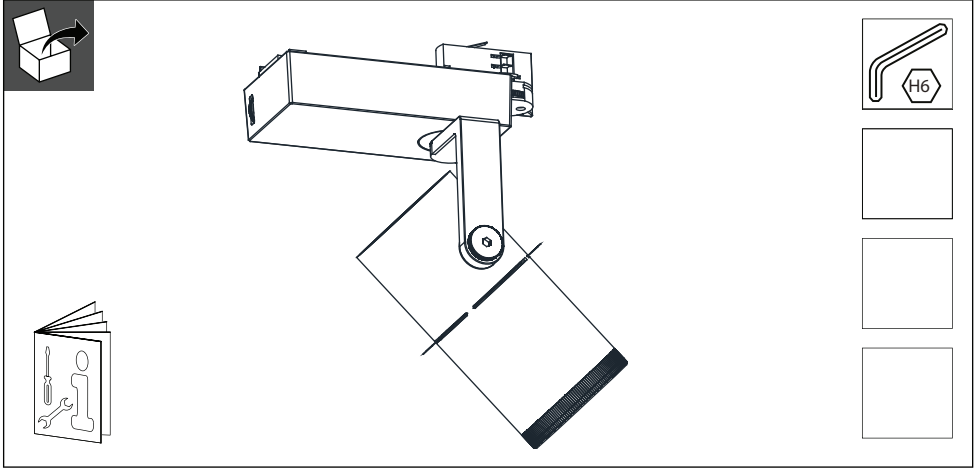

220 V  
240 V

50Hz  
60Hz



LEDs

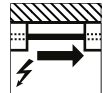

	P (W)	IP...	kg
ST512T	23	IP20	1.85

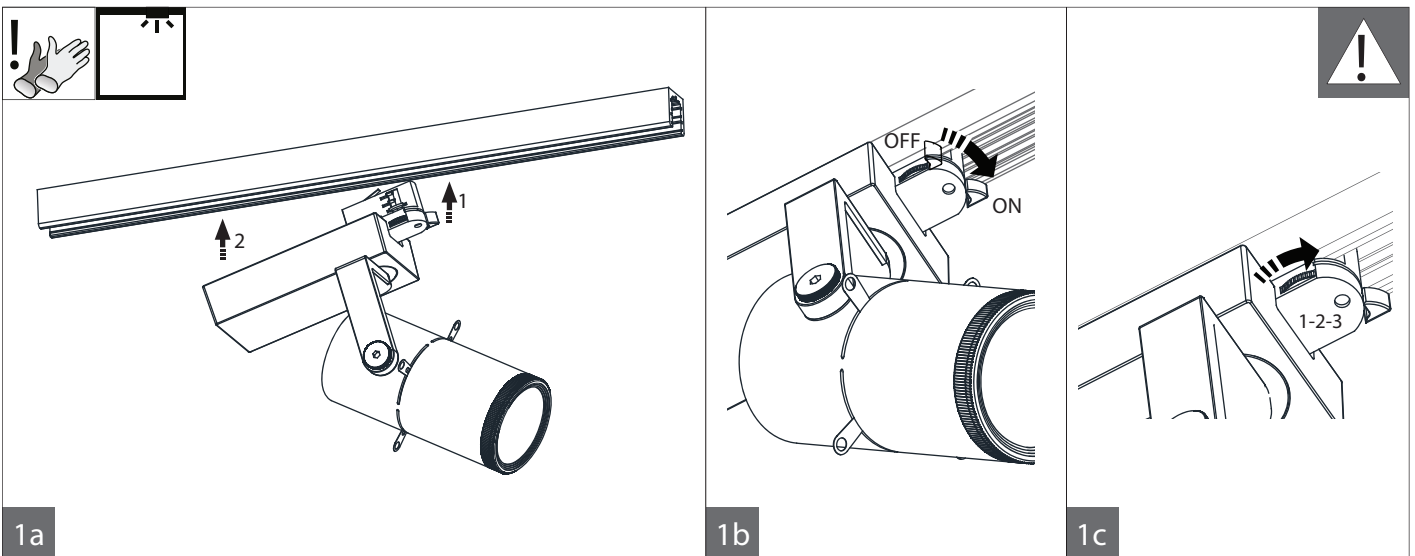
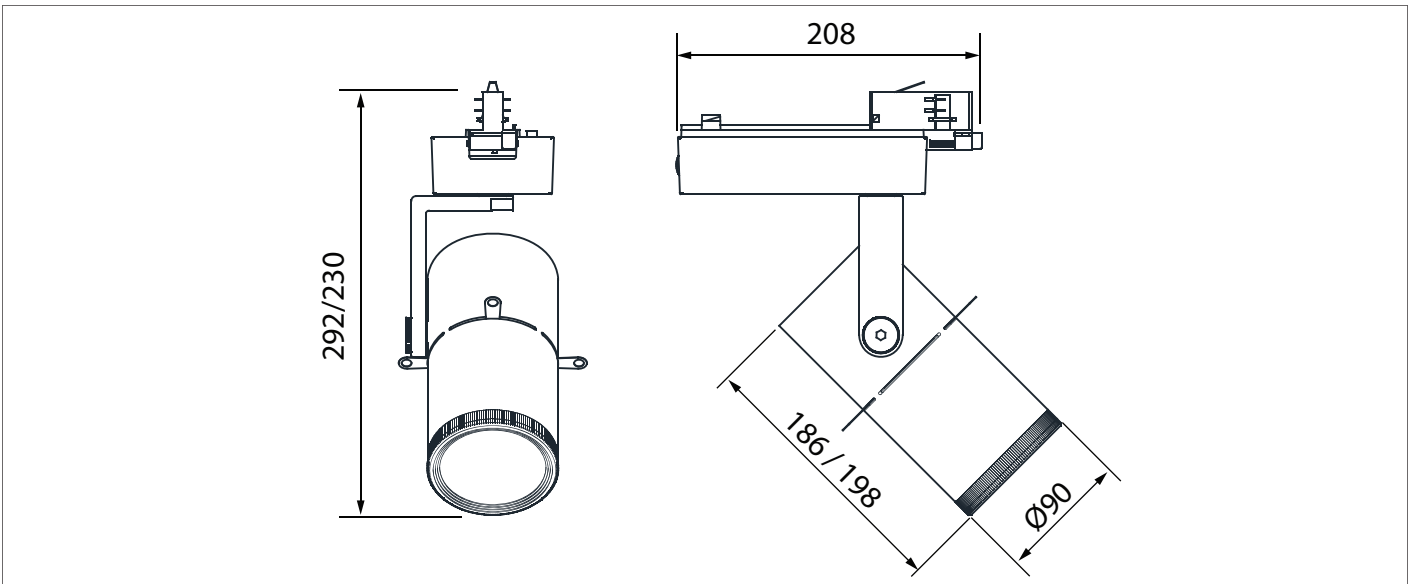

GLOBAL Trac Pro  
Wiring options:

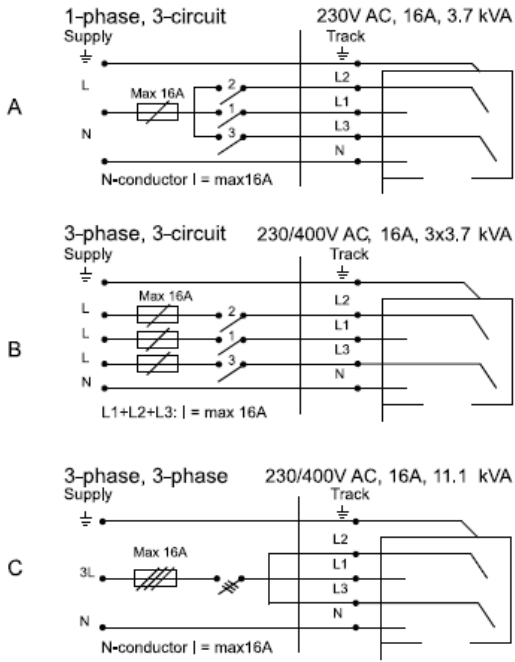

90°  
△

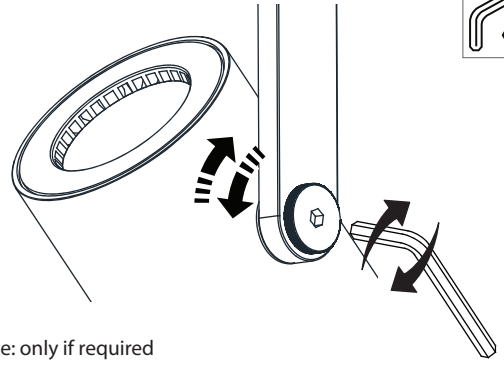

2

note: only if required

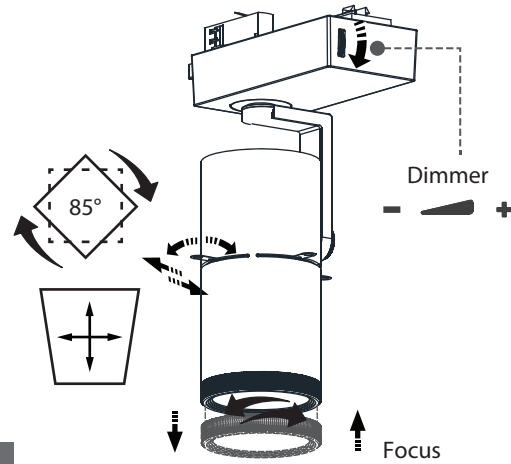

3

Focus

1d

Inrush current

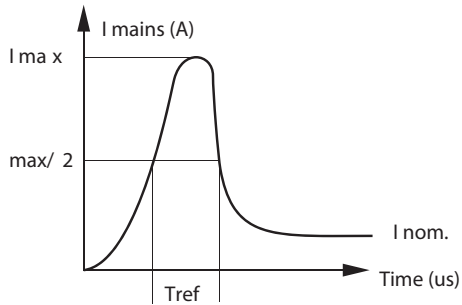

MCB	Downlights Max.
B-10 A	57
B-13 A	74
B-16 A	91
C-10 A	57
C-13 A	74
C-16 A	91

Example of applications:

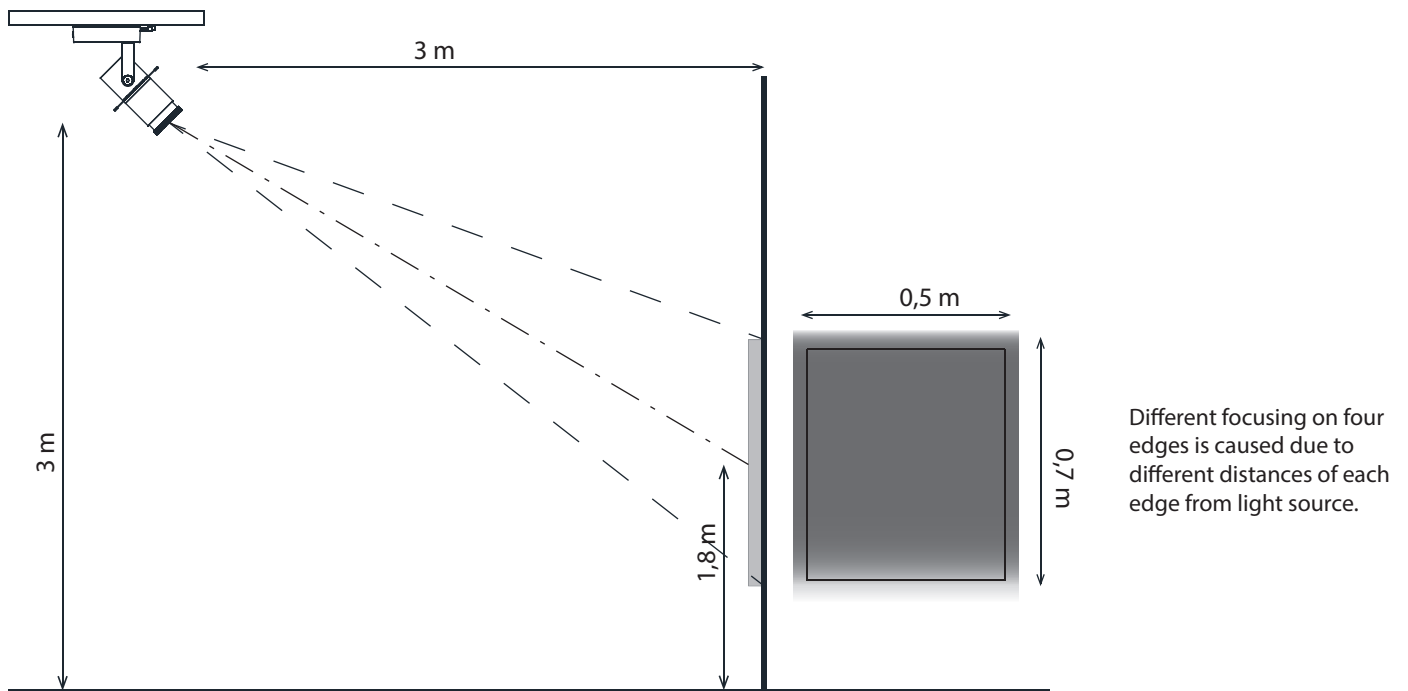

How to get straight sides:

CORRECT POSITION OF FRAMING KNIVES

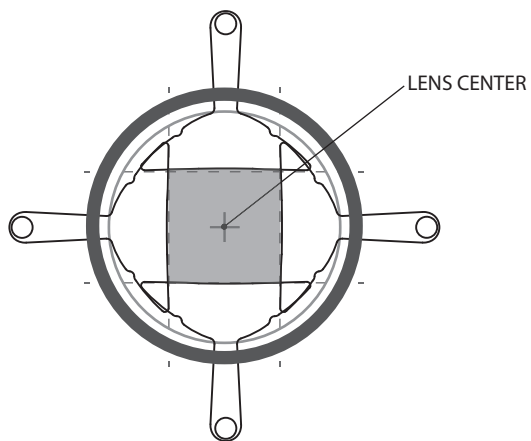

NOT CENTERED FRAMING KNIVES TOWARDS LENS

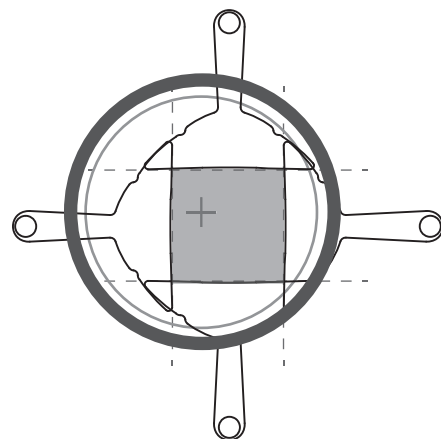

Not uniform squared light beam if framing knives are not correctly positioned upon the center of lens.