

# Indal

MONTAGE VOORSCHRIFT  
INSTALLATION INSTRUCTIONS  
MONTAGEANWEISUNG

LIBRA PERFORMER  
2565/2566/2567/2570/2571/2572

INSTRUCCIONES DE MONTAJE  
INSTRUCTION D'INSTALLATION  
INSTRUÇÕES DE MONTAGEM

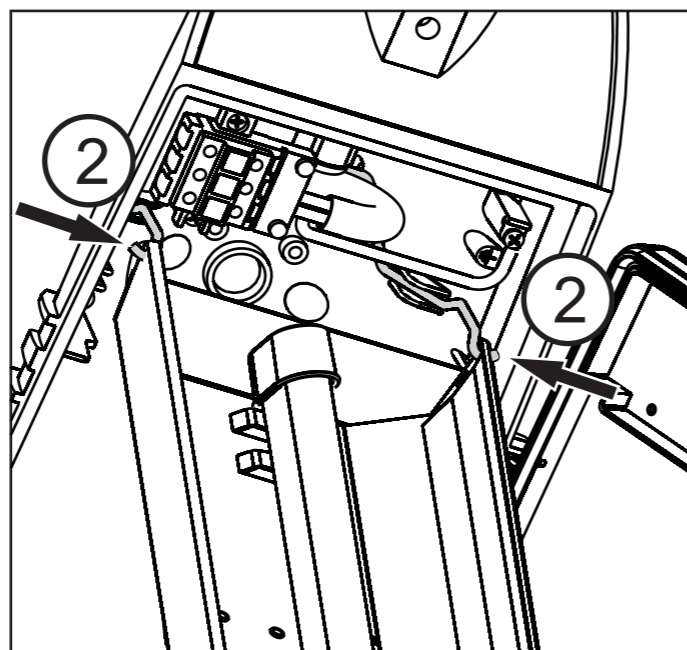
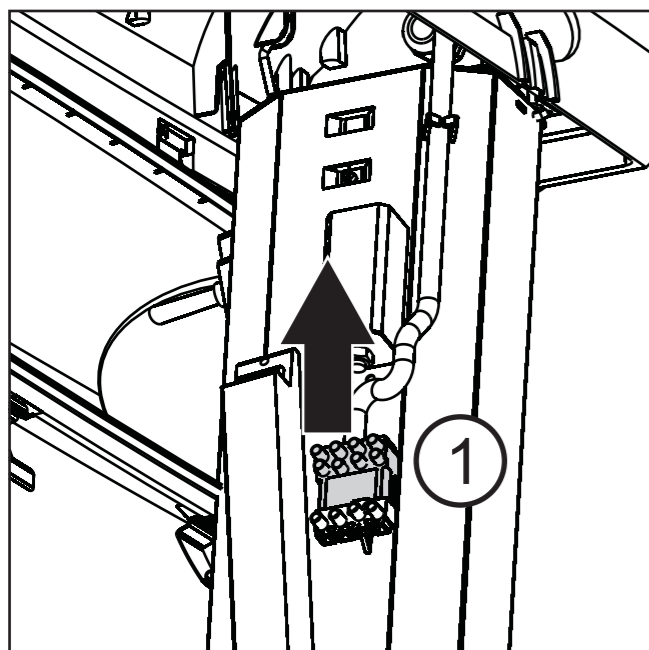

Operation instructions for Indal light fitting type Libra 65 and 70  
Please read the instructions carefully before starting any works!

#### Content:

1. Safety instructions
2. Conformity with standards
3. Technical data
4. Installation & installation instructions
5. Taking into operation
6. Maintenance

#### 1. Safety instructions

For skilled electricians and trained personnel in accordance with national legislation, including the relevant standards.

Observe the national safety rules and regulations for prevention of accidents and the following safety instructions:

- The technical data indicated on the lighting fitting and the gear are to be observed.
- Changes to the design and modification to the light fitting are not permitted.
- The light fitting shall be operated as intended and in undamaged and perfect condition.
- Repairs may only be carried out by a qualified "electrician".
- Do not keep these operation instructions inside the fitting during operation.

#### 2. Conformity with standards

- This lighting fitting meets requirements of EN 60 598.
- It has been designed, manufactured and tested as a state of art product and according to EN ISO 9001-2000 quality management system.
- It has been ENEC tested, certificate KEMA 2096704.01.
- It meets CE requirements.

#### 3. Technical data

Technical details are stated on the product label. This label states lamp type, lamp wattage, supply voltage and frequency, power factor/cos phi, nominal current, electrical insulation class (if class 2, double insulated), maximum ambient temperature (if nothing stated the maximum ambient temperature is 25°C), IP value, CE mark and ENEC mark (if applicable for this version).

- Ingress Protection: IP 65 complete (standard). Option of IP 66 available.
- Supply terminal: Terminal block (standard). Option of plug-socket or circuit breaker available.
- Storage temperature in original packaging: -40°C to +60°C.
- Cable gland: 1 x M20, for round cables of 7-14mm in diameter.
- Mounting fixation Libra 2565/2567 and 2570/2572: 2 x M10, 20Nm.
- Mounting fixation Libra 2566 and 2571: 1 x M10, 20 Nm.

#### 1. Installation

- Observe the respective national regulations as well as the general rules of engineering which apply to the installation and operation of electrical apparatus. Transport and storage of the luminaire is permitted in original packaging and specified position only.
- Installation instructions are included in the packaging of each luminaire.
- Only use such lamps that have been certified for these light fittings. See type label on the packaging or in the luminaire for the intended type.

#### 2. Taking into operation

Prior to operation, check the light fitting for its proper functioning and installation in compliance with these operation instructions, the installation instructions and other applicable regulations.

#### 3. Maintenance (every 4 years or at lamp change; whatever is the shortest period)

The manufacturer guarantee is subject to the effective and scheduled fulfilment of the mentioned regular maintenance tasks, by specifically skilled and authorised workers, as well as to the information (regular shipment of maintenance or repair reports), and also to the lack of changes in the luminaires working condition (vibration levels, traffic, environment, etc.).

Observe the national regulations applicable to the maintenance, servicing and testing of electrical apparatus as well as the general rules of engineering.

#### Service:

When servicing, in particular those components that affect the type of protection, will have to be checked and replaced if applicable, e.g.;

- Housing and bowl for any cracks or damages e.g. in paint finish.
- Gaskets for their perfect condition. Grease the gasket with acid-free grease.
- Terminals for their firm fit.
- In case of IP 66 rating, cleaning of the interior of the luminaire should not be necessary.
- Because of risk of electrostatic charge, the light fitting shall only be cleaned with a damp cloth or sponge. Only use customary household wash-up liquid diluted in water as specified. The water temperature may be hand warm. After cleaning, rinse with clear water.
- Lamp replacement: keep replacement intervals as specified by the lamp manufacturer.

#### Repair:

Prior to replacing or removing any components or lamps, observe the following:

- Even though this lighting fitting may (optionally) be equipped with a circuit breaker, we advice to disconnect the lantern from the power supply before opening or carrying out repairs!
- Only use genuine Indal spare parts.

2570

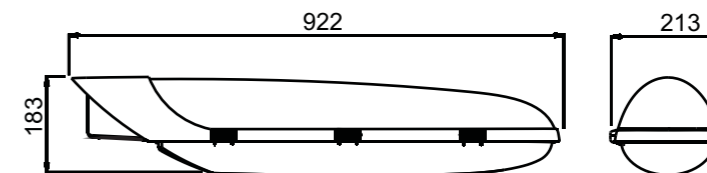

2571

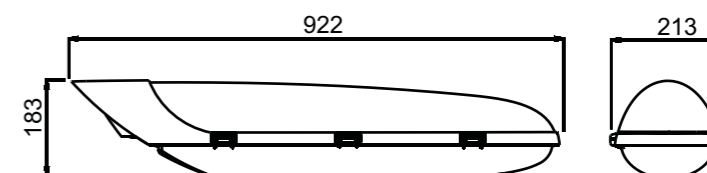

2572

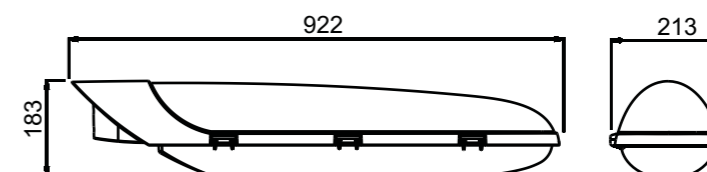

2565

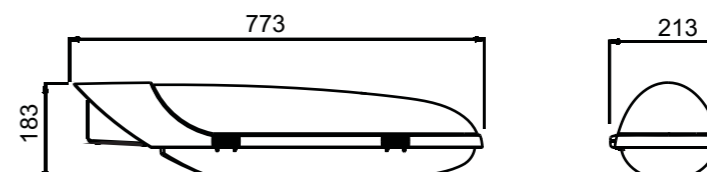

2566

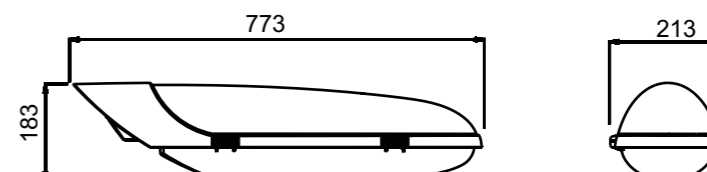

2567

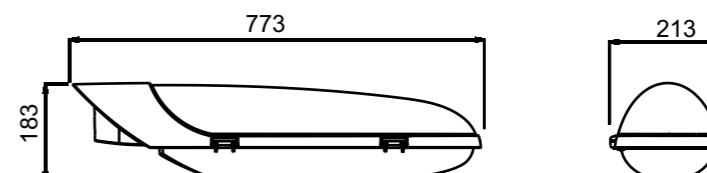

	W	Kg Max	m <sup>2</sup>	Cx·s	Min	Max	Nr..

FSD 18	19	5.5-5.8	0.10	0.083	-20°C	40°C	2565/66
FSD 24	27	5.5-5.8	0.10	0.083	-20°C	40°C	2565/66
FSD 36	39	5.5-5.8	0.10	0.083	-20°C	40°C	2565/66
FSD 40	45	6.6-7.0	0.13	0.095	-20°C	40°C	2570/71
FSD 55	62	6.6-7.0	0.13	0.095	-20°C	40°C	2570/71
FSD 80	86	6.6-7.0	0.13	0.095	-20°C	40°C	2570/71

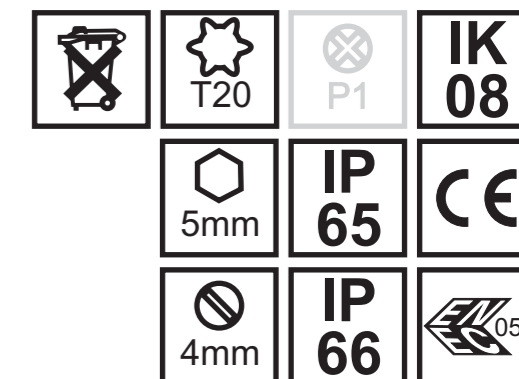

Data subject to change. Rev. Date: 18/02/2010

