

Installation sur mât spécifique mâle *on specific male pole / sobre mástil específico varonil*

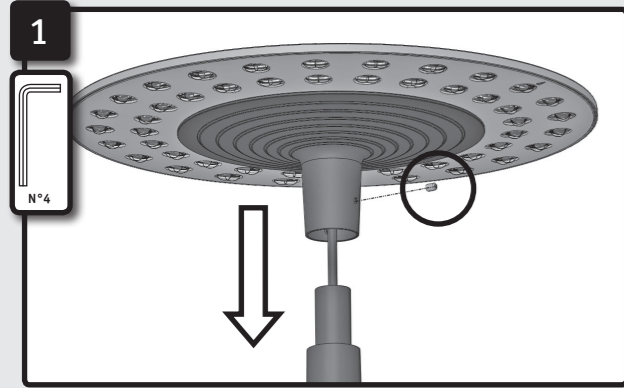

Placer le luminaire sur le mât et serrer la vis de pression
Pass the cable and screw lantern head
Pasar el cable y apretar el tornillo de fijación

Installation sur mât standard femelle *on standard female pole / sobre mástil estándar hembra*

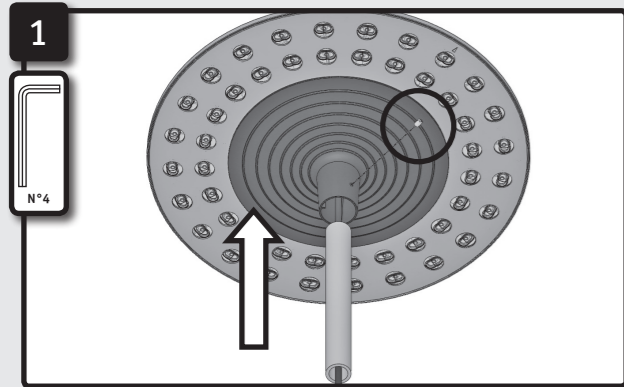

Placer le tube intermédiaire et serrer la vis de pression
Place the intermediate tube & tighten the pressure screw
Colocar el tubo intermediario y apretar el tornillo de fijación

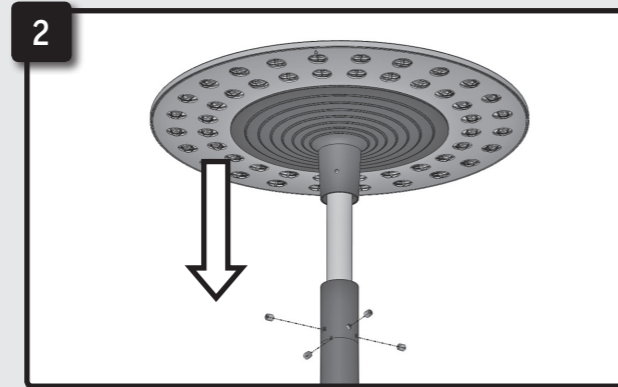

Placer l'ensemble dans le mât, serrer les 8 vis du mât
Place the group on the pole, tighten the 8 screws of the pole
Colocar el conjunto en el mástil, apretar los 8 tornillos del mástil

Accès aux appareillages

Access to control gear / Acceso al equipo

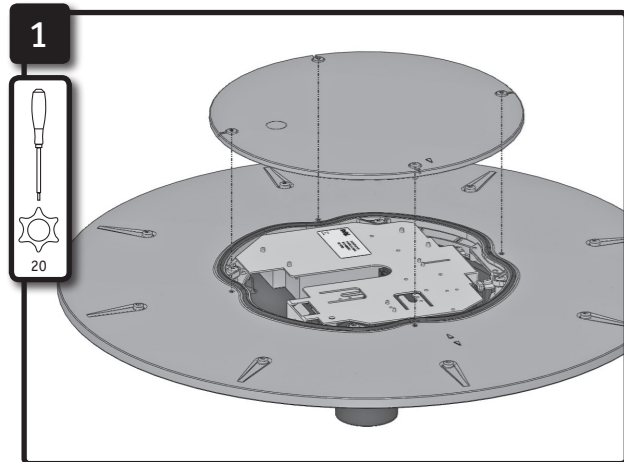

Déposer le couvercle supérieur
Put down the upper lid
Depositar la tapa superior

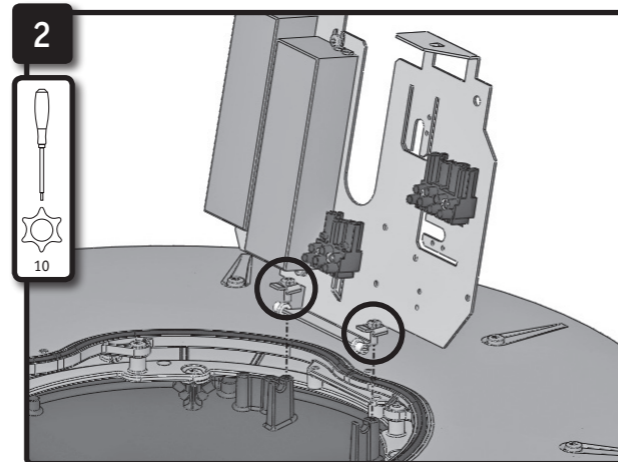

Déconnecter les 2 connecteurs, dévisser les 2 vis de fixation de la platine, retirer la platine
Unplug the 2 connectors, unscrew the 2 control gear screws & remove it
Intape los 2 conectores, desatornillar los 2 tornillos del equipo y quitélo



Attention : Veuillez lire attentivement le présent manuel avant d'installer, d'utiliser ou de réparer le produit présenté ci-après. La non observation des instructions et recommandations peut entraîner un risque de blessure personnelle et/ou de dommage matériel. Veuillez conserver ce manuel pour référence ultérieure.

Exercer un couple de serrage de 25 N.m aux vis qui fixent le luminaire sur son support.



Attention: Read this guide carefully before installing, using or repairing the product. Failure to observe the instructions and recommendations may cause a risk of personal injury and/or material damage. Please keep this guide for future reference.

Tighten the screws which fix the luminaire and its bracket by 25 N.m.



Atención : Lea atentamente el presente manual antes de instalar, usar o reparar el producto presentado a continuación. El incumplimiento de las instrucciones y recomendaciones puede causar un riesgo de daños personales y/o materiales. Por favor conserva este manual para referencia ulterior.

Aplicar un par de apriete de 25 N.m sobre los tornillos que fijan la luminaria a su soporte.

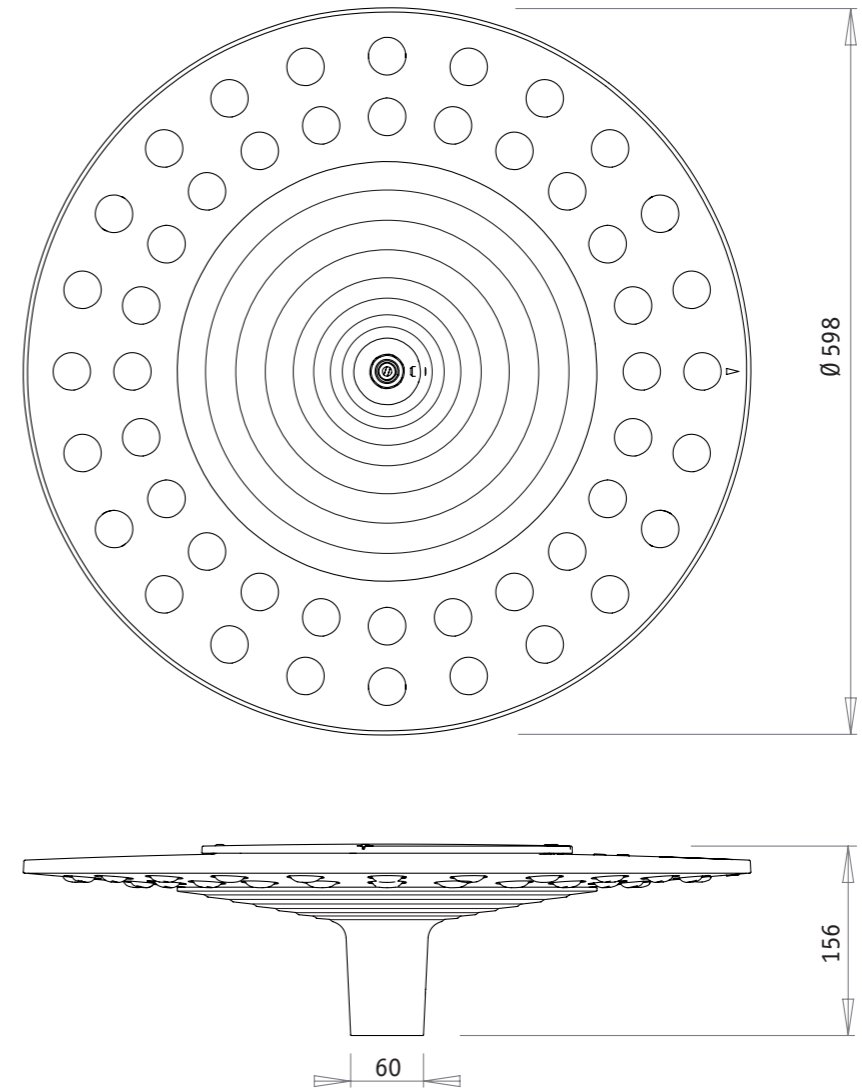

Intensité / intensity / intensidad	250 / 350 / 500 / 700 mA
Puissance maxi / Max. wattage / Potencia máxima	105 W
Distribution / distribution / Distribución	Road / Area
Etanchéité du bloc optique / IP optical unit / IP unidad óptica	IP 66
Classe / Class / Clase	I - II
Choc (corps) / Impact resistance (body) / Resistencia al impacto (cuerpo)	IK 10
SCx / SCx / SCx	0.03 m ²
Poids max / Max. weight / Peso máximo	7.5 Kg
Nombre de LED / LED quantity / Número de LED :	12, 18, 24, 36, 48
Norme / Standards / Norma	EN 60598-1 et / and / y EN 60598-2-3
Hauteur d'installation / Mounting height / Altura de instalación	4 m

NOT0074-A

Zone de Pompey Industries
54 670 Custines (France)
Tel : +33 (0)3 83 49 63 63
Fax : +33 (0)3 83 49 11 11

www.indal-france.com

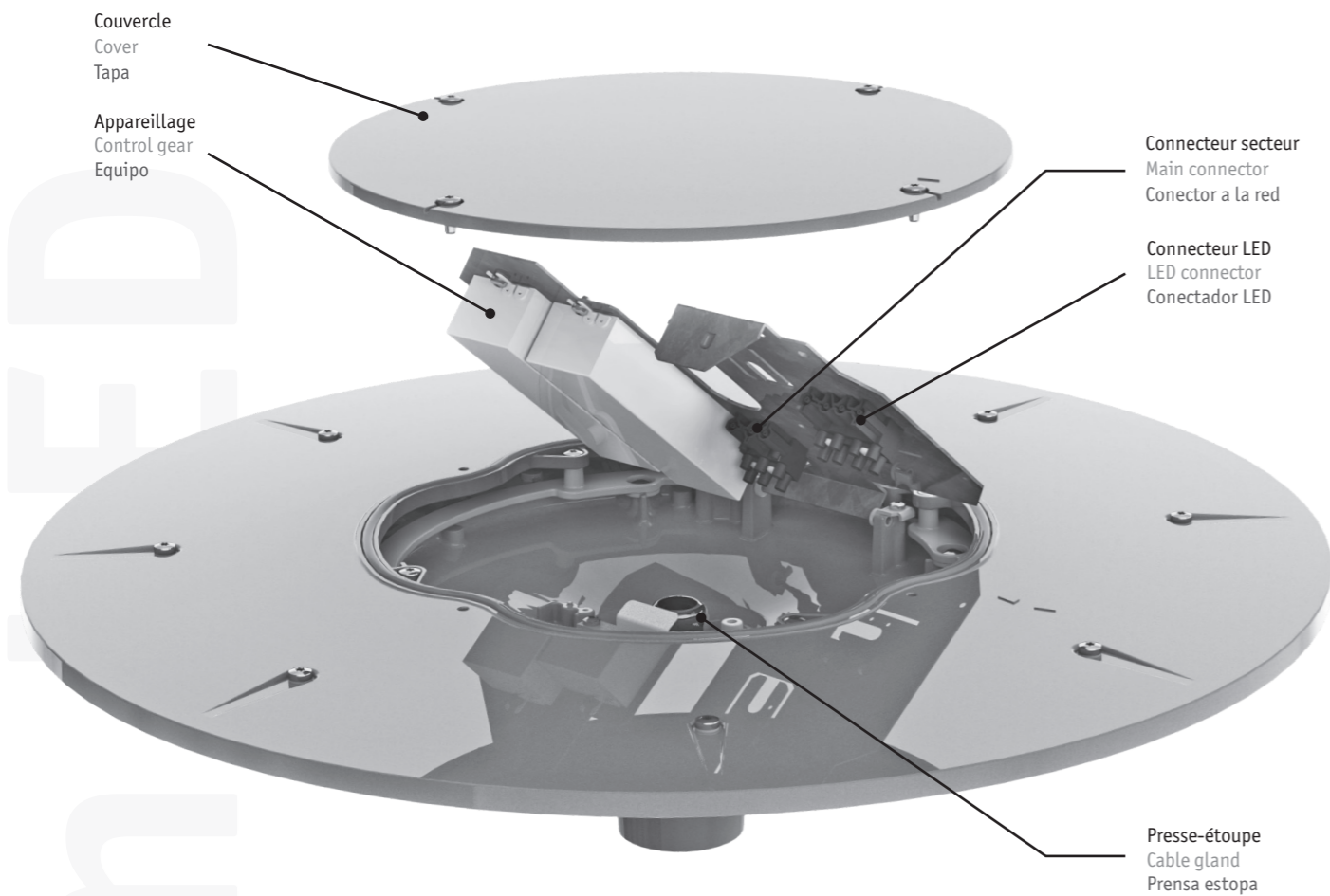

Installation du luminaire *Luminaire installation / Instalación del alumbrado*

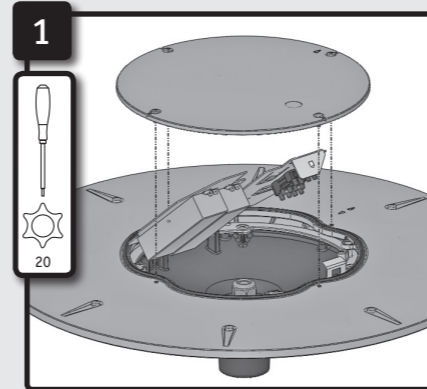

Déposer le couvercle supérieur et basculer la platine
Put down the upper lid and tip over the control gear
Depositar la tapa superior y volcar el equipo

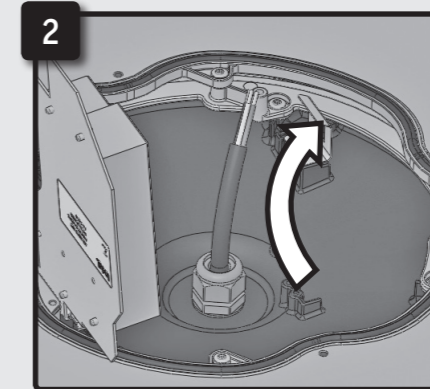

Passer le câble dans le presse étoupe
Pull the cable into the cable gland
Pasar el cable gracias al guía de cable

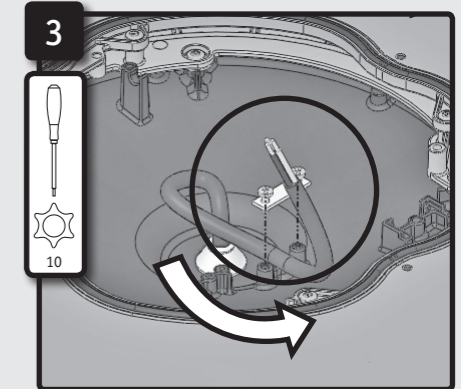

Ou passer le câble dans le passe fil et la bride
Or pass the cable into the blocking piece & the rein
O pasar el cable en lo pasa hilo y la rienda

Cablage platine *Control gear connecting / Conexión equipo*

Classe I

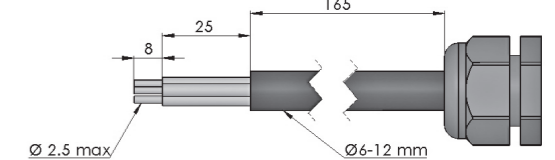
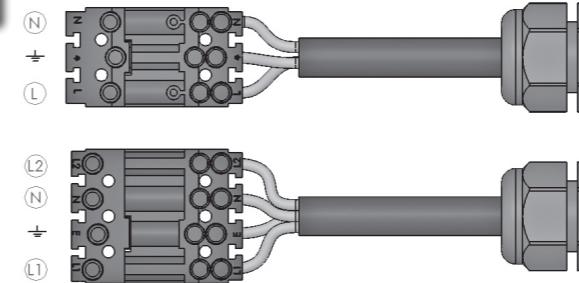

Classe II

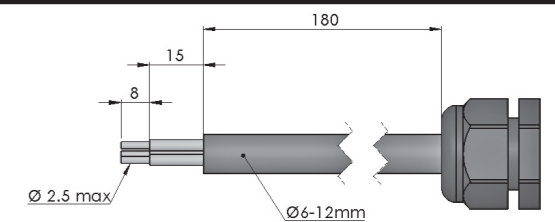
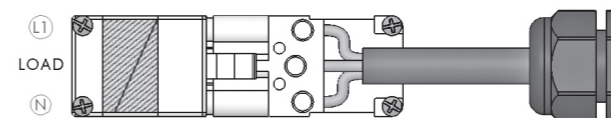

Cellule photoélectrique *Photocell / Célula foto eléctrica*

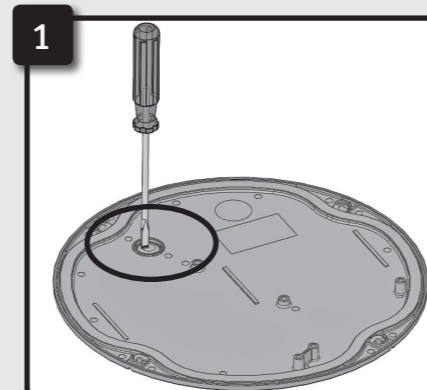

Défoncer localement le couvercle
Make a hole in the lid
Hacer un hoyo en la tapa

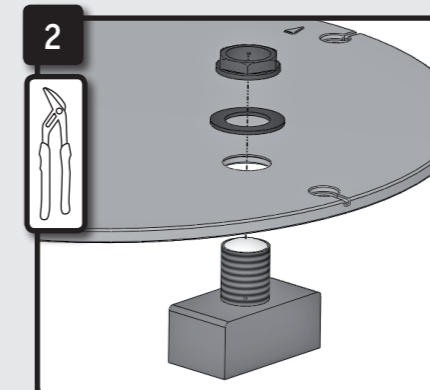

Placer la cellule
Place the photoelectric cell
Colocar la célula foto eléctrica

