

Lumiblade OLED Panel Brite FL300 L ww + wm



Rectangle is the new square

With the Brite FL300 L Lumiblade is introducing yet another member to its Brite family of functional OLEDs. This time, size does matter as the FL300 L is opening new possibilities due to its form factor. The rectangular OLED (approx. 6.3 x 24 cm/2.48 x 9.45 in) provides 300 lumen and an efficiency of 50 lumen per watt and is the ideal OLED for all applications where the homogenous light needs to be distributed over a larger area or where the design calls for a slim shape of the OLED.

The Brite FL300 L is available in two integration levels and two different finishes. The FL300 L ww is the world's brightest commercially available OLED panel and the FL300 L wm combines brightness with highly decorative mirror appearance.

Benefits

- Brightest OLED panel commercially available with up to 300 lumen and up to 50 lm/W.
- Available in 3,000 K (for FL300 L ww) and 2,500 K (for FL300 L wm).
- Thin-Film Encapsulation for ultimate reliability.
- Integrated intelligence for easy and correct driver recognition. Compatible Lumiblade drivers available (including DALI, DMX and 0-10V).
- Available at two different integration levels.
- The FL300 L ww ideal for general and functional lighting applications and the FL300 L wm ideal for general and highly decorative lighting applications.
- All the known advantages of OLED technology.

Product features

- Low thicknesses of 1.1 to 3.0 mm.
- Up to 300 lm/panel, dimmable.
- Lumen efficacy up to 50 lm/W.
- CRI 80.
- Interface for intelligent device recognition with compatible drivers.

Applications

Every OLED light-application that is commercially viable and easy to implement. Special light application for interior spaces that require beautiful and high performance lighting.

Description

The Philips Lumiblade OLED Panel Brite FL300 L is a flat light source. Focusing on general lighting applications, Lumiblade OLED Lighting is developing products with a high lumen output at low costs for the mid- to long-term future. One significant step in this direction is the range extension of the Philips Lumiblade OLED Panel Brite FL300 L ww and wm which are available at two different integration levels.

Introduction

Lumiblade is the brand name for OLED lighting at Philips. Lumiblade is a large-area diffuse light source. Unlike incandescent bulbs, which generate light by passing electricity through a wire, or fluorescent lamps, which pass current through a gas, OLED lighting works by passing electricity through one or more extremely thin layers of organic semiconductor material. These layers are sandwiched between one positively and one negatively charged electrode. The 'sandwich' is placed on a sheet of glass or other transparent material known as the substrate. The OLED is protected by a thin-film encapsulation and a flat heat spreader on the rear side. When current is applied to the electrodes, they inject positively and negatively charged holes and electrons. They recombine in the organic layer of the sandwich and create a brief, high-energy state called 'exciton'. As this layer returns to its original stable, non-excited state, the energy flows evenly through the organic film causing it to emit light.

Now, with the ambition of entering large-scale markets with highly sophisticated, standardized lighting technology, these products are defined around value propositions of the predominant markets and the market needs within the relevant applications.

In contrast to virtually all previous OLED products the Philips Lumiblade OLED Panel Brite FL300 is a product that for the first time attains the status of a general lighting application. As part of its ongoing product improvement, Lumiblade will continue to develop the OLED Panel Brite FL300 to higher levels of performance in different shapes and sizes.

This document refers to

Product	Integration Level	Product Code
Philips Lumiblade OLED Panel Brite FL300 L ww N w/o Rset	1	9254000 320
Philips Lumiblade OLED Panel Brite FL300 L ww A0	2	9254000 330
Philips Lumiblade OLED Panel Brite FL300 L wm N w/o Rset	1	9254000 290
Philips Lumiblade OLED Panel Brite FL300 L wm A0	2	9254000 300

Standard compliance and sustainability

Philips Lumiblade products are environmentally friendly and provide efficient illumination without the use of hazardous materials.

This product is RoHS (EU Directive 2011/65/EU) compliant.



This product is compliant with UL8752. This product is UL recognized in file E353273.



Within the UL report certain 'Conditions of Acceptability' are mentioned as follows. When installed in the end product, the following shall be taken into consideration:

1. These products have been evaluated for connection to an isolated DC Class 2 constant current power source.
2. This product has been evaluated for use in dry or damp locations.
3. The OLED panel temperature shall not exceed 80 °C.
4. Input leads to the OLEDs are intended for factory installation only. Strain relief to be considered in the end-use application if leads are subjected to mechanical stress.
5. Input leads to the OLED panels shall be sufficiently separated from higher voltage conductors in the end-product in compliance with end-product requirements.

System

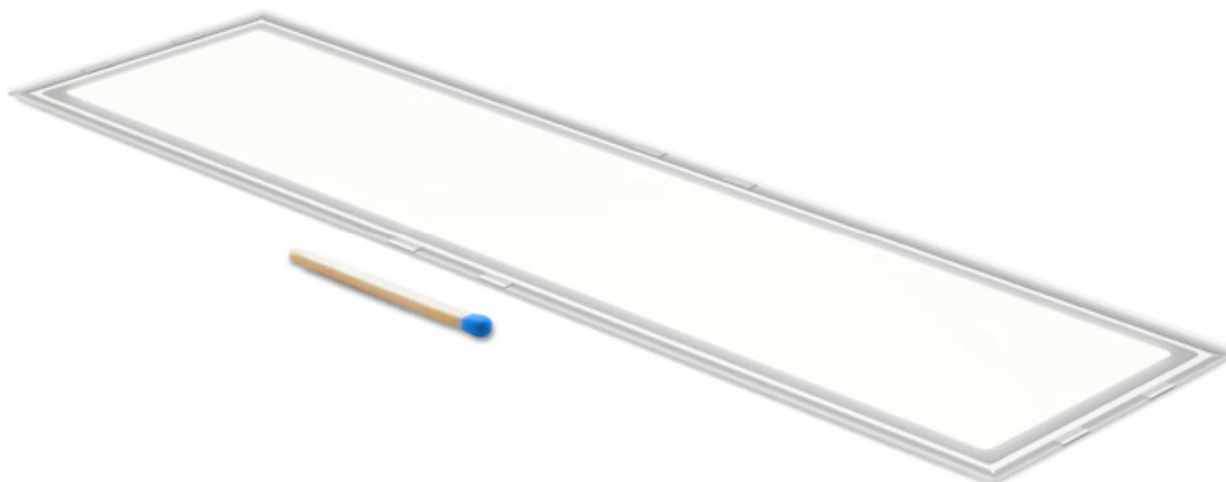

Figure 1: Philips Lumiblade OLED Panel Brite FL300 L ww N w/o Rset

	Description	Remark
Indoor / outdoor	Indoor buildings	location with insignificant shock and vibration
Ingress protection		not applicable for OLED components
Classification	Applicable in applications with Class III protection	Application standard IEC61140
OLED color	White	
Carrier material	Glass	
Cable	AWG 26	Philips Lumiblade Brite FL300 L ww A0
Connector	5-pin Molex Picoblade	Philips Lumiblade Brite FL300 L wm A0
RoHS conform	Yes	2011/65/EU

ENVIRONMENTAL

Operational environmental conditions*

Specification item	Value	Unit	Condition
Ambient temperature	+5 ... +40	°C	
Relative humidity	20 ... 80	%rH	no dew, no water spray, a maximum %rH of 60 is recommended.
Recommended internal operation temperature (temperature of OLED emission side)	≤ 50	°C	local temperature
Maximum internal operation temperature (temperature of OLED emission side)	≤ 80	°C	local temperature, for $t > 50$ °C lifetime will be reduced.

* please refer to Thermal Characteristics on page 24 for more information.

The Brite FL300 L is designed for indoor use only. Do not expose to water or excessive moisture.

Storage conditions*¹

Specification item	Value	Unit	Condition
Ambient temperature	-40 ... +60	°C	
Relative humidity	5 ... 85	%rH	no dew, no water spray

*¹ Recommended storage temperature is between 15 ... 25 °C with a humidity < 65 %rH.

Transport conditions

Specification item	Value	Unit	Condition
Ambient temperature	-40 ... +60	°C	
Relative humidity	5 ... 85	%rH	no dew, no water spray

MECHANICAL DIMENSIONS

Specification item		Value	Unit	Condition
Brite FL300 L ww N w/o Rset	length	240.6 ±0.2	mm	
	width	62.7 ±0.2	mm	
Brite FL300 L wm N w/o Rset	height	1.1 ±0.15	mm	
	weight	36.4 ±0.5	gram	
Brite FL300 L ww A0 Brite FL300 L wm A0	length	248.1 ±0.15	mm	dimensions excluding cable
	width	70.2 ±0.15	mm	
	height	2.1 ±0.2	mm	excluding Molex Picoblade plug
	diameter screw opening	3.2	mm	for fixation with M3 screws
	distance screw openings	123.8 ±0.2 247.5 ±0.2 69.6 ±0.2	mm	
	weight	69 ±0.8	gram	
Light emitting area	length	222 ±0.2	mm	Brite FL300 L ww N w/o Rset Brite FL300 L wm N w/o Rset Brite FL300 L ww A0 Brite FL300 L wm A0
	width	46 ±0.2	mm	
	area	102.1	cm ²	

Diagrams of the Brite FL300 L ww and wm N w/o Rset (integration level I)

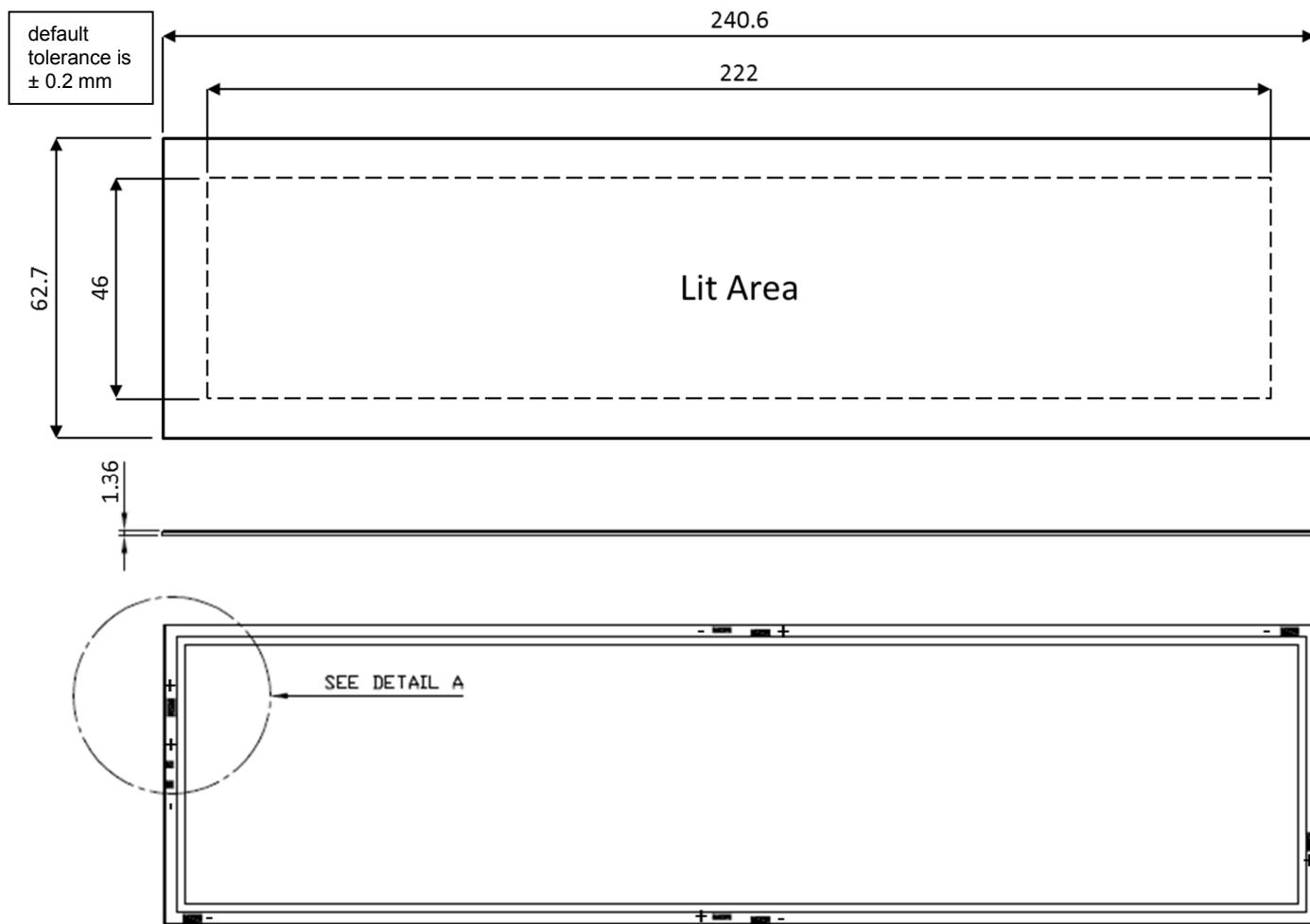

Figure 2: Brite FL300 L ww N w/o Rset – front (top), side view (middle), rear view (bottom) - integration level I

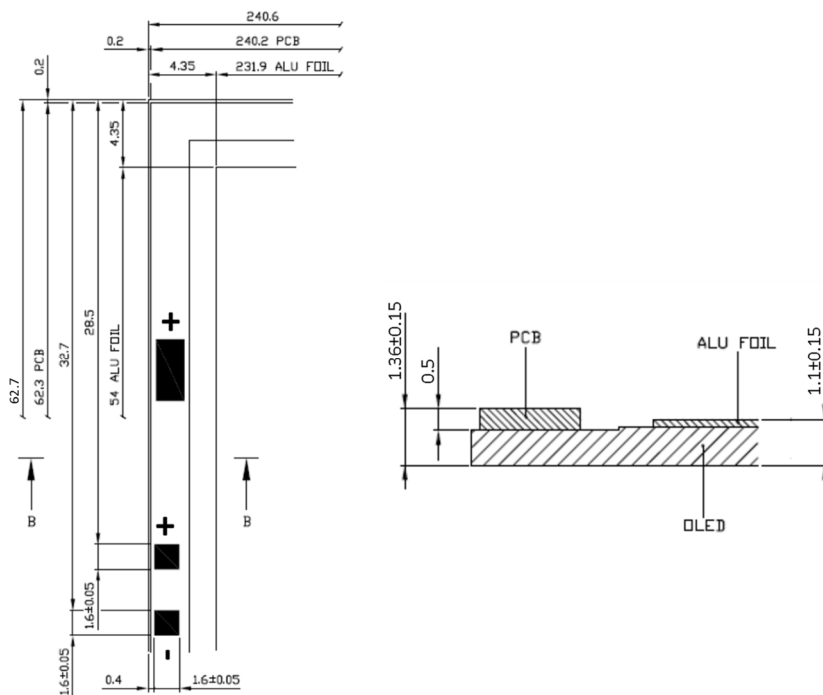

Figure 3: Detail A of Figure 2 (left) and cross section B-B (right); Brite FL300 L ww N w/o Rset

Diagrams of the Brite FL300 L ww and wm A0 (integration level 2)

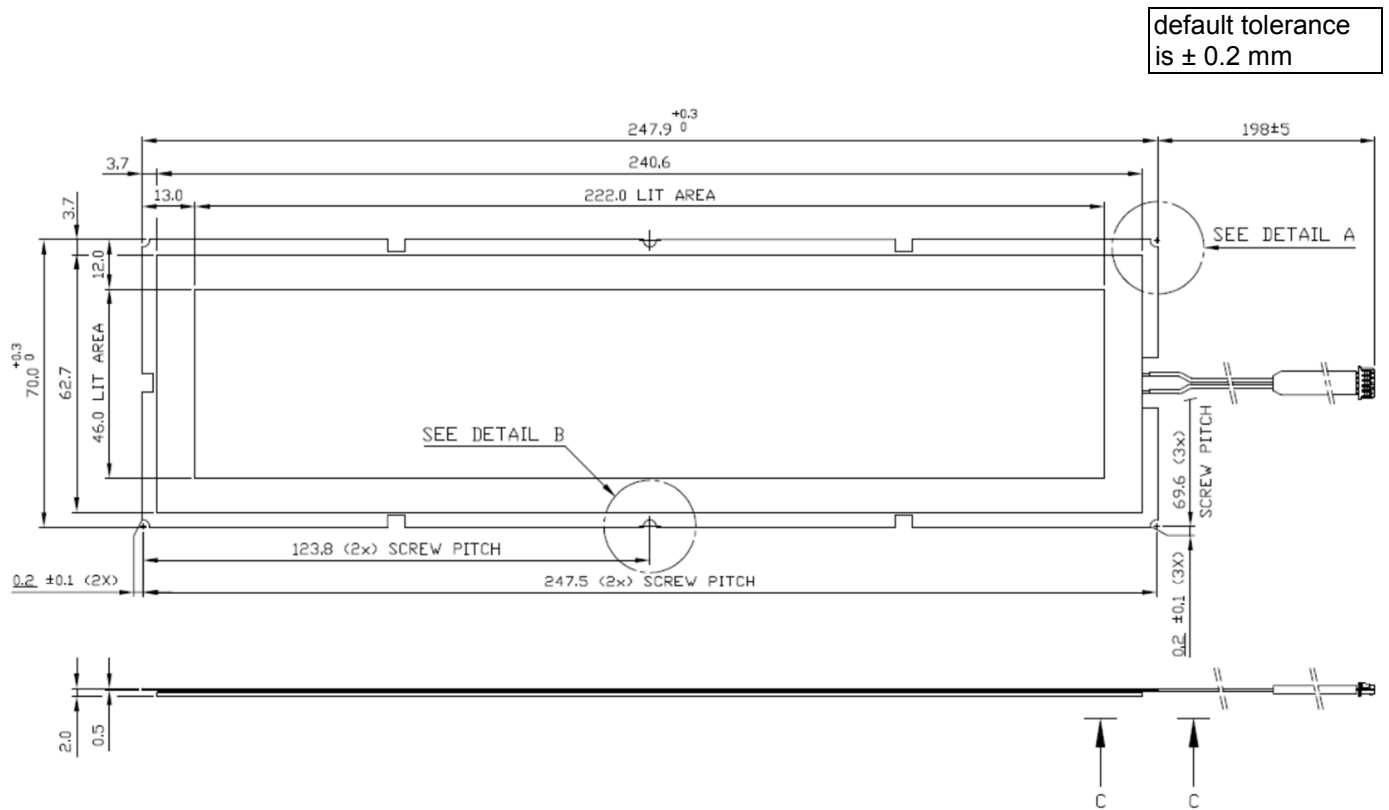

Figure 4: Brite FL300 L ww A0 – front and side view (top), side view (bottom) - integration level 2

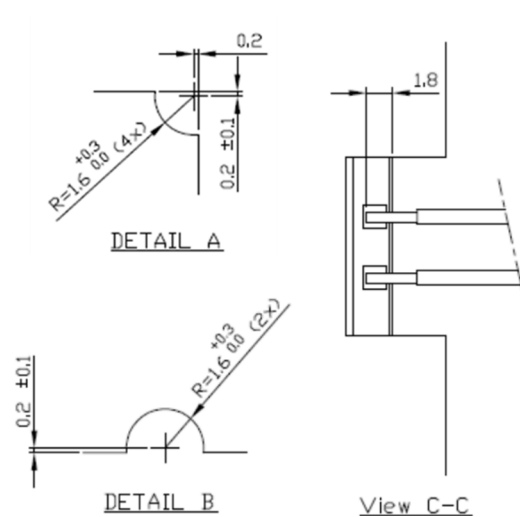

Figure 5: Details A and B (screw openings) and view C-C (solder orientation on PCB) of Figure 4 –integration level 2

Mechanical handling

OLEDs are electronic components and should not be tampered with in any way. They are made of thin glass with potentially sharp edges. Avoid mechanical stress, such as shock, pressure, bending, torsion and especially point loads on the OLED. To avoid fingerprints on the front side, preferably handle the OLED from the sides. Gloves or finger cots are recommended at all times whilst handling the OLED.

Avoid contact with water. Do not submerge OLEDs in any kind of solvent, acid, base, salt or other chemicals.

In case of damage to the product, disconnect the product from power supply without touching the damaged parts. Do not reconnect the product. Contact the manufacturer or a qualified service technician.

Improper use can cause OLEDs to break resulting in glass splinters. Please handle all OLEDs with care to avoid breakage as especially the edges of the OLED are very delicate. Use of protective gloves is advised, in particular with broken OLEDs or OLEDs with sharp edges/corners. Avoid direct contact with broken OLEDs.

The product may become warm during normal use. Do not cover with materials that are flammable.



Do not bend



Do not twist



Do not press

ELECTRICAL AND OPTICAL CHARACTERISTICS - OLED

Electrical characteristics

Specification item	Value	Unit	Condition
OLED rated current, $I_{in \text{ rated}}$	0.368	A	
OLED maximum current, $I_{in \text{ max}}$	0.390	A	
OLED voltage at $t=0$, U_{in}	20.0 + 0.5/- 1.0	V DC	$I_{in \text{ rated}}$
OLED voltage at end of life, $U_{EOL} = U_{in \text{ max}}$	25.5	V DC	$I_{in \text{ max}}$
Power consumption at $t=0$, P_{in}	7.4	W	$I_{in \text{ rated}}$
Power consumption at end of life, $P_{EOL} = P_{in \text{ max}}$	10.0	W	$I_{in \text{ max}}$

All data nominal at stabilized conditions after 5 min warm-up, $T_{\text{organic}} = 50 \text{ }^{\circ}\text{C}$.

OLED drivers

Use of power supplies with dedicated controls for turning off output power if an OLED fails is recommended when operating the Philips Lumiblade OLED Panel Brite FL300 L ww and wm. Recommended drivers are shown in the table below. These drivers all have sockets compatible with the Molex Picoblade connector.

Product	Supply voltage	Output channels	Product Code
Driver D230V 80W/0.1-0.5/1A/28V TD/A 8CH	120, 220-240, 277 V AC	8	9254.000.10200
Driver D024V 10W/0.1A-0.4A/28V D/A	24 V DC	1	9254.000.10100
Driver D024V 10W/0.1A-0.4A/28V DMX	24 V DC	1	9254.000.12000

Dimming

Both pulse width modulation (PWM) and amplitude modulation (AM) techniques can be used to dim the OLED. More detailed information can be found in the design-in guide for the Brite FL300 family.

OLED connection

The Philips Lumiblade OLED Panel Brite FL300 L is available at different integration levels. At integration level 1, no cable is attached to the device. Integration levels 2 provide a cable with a Molex Picoblade connector type compatible with the Lumiblade OLED driver electronics.

At integration level 1 the Brite FL300 L features contact areas on the rear side (see Figure 6). Area A provides contact pads A1, 3, 5, 7, 9 (plus) and A2, 4, 6, 8, 10 (minus). The individual signals for the 5-wire connector are shown in Figure 7. Only one of the interface areas must be used for electrical contact.

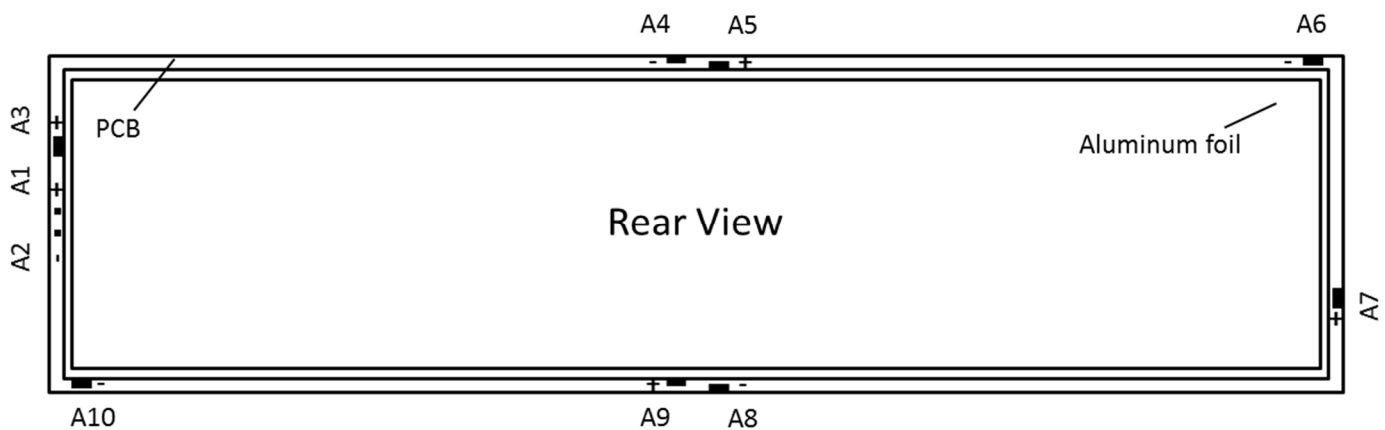

Figure 6: Channel connections from driver to the Brite FL300 L – integration level 1

The function of the connector is illustrated in Figure 7. A1 and B1 link to the plus pole and A2 and B5 link to the minus pole. B2, B3 and B4 are used to connect to resistors which encode the proper driving window and failure detection mode of the panel. Hence, using the 5-wire connector of the integration level 2 according to the schematic in Figure 7 the dedicated Lumiblade OLED drivers automatically recognize the panel and drive it correctly.

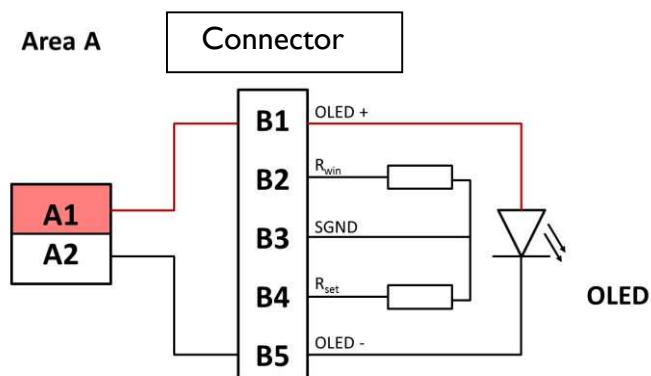

Figure 7: Contact pads of the Brite FL300 L ww and wm A0 – integration level 2

Specification item	Value	Unit	Remark
Wire cross-section	26	AWG	flat cable; voltage rating: 300 V; circuits: 5
Wire length	198 ± 5	mm	
Connector (header/crimp)			Molex Picoblade male

OLED voltage

The voltage of the OLED depends on the point of operation, temperature of the organics and the age of the OLED. As a result, the OLED voltage is affected by the ambient temperature. During operation the temperature of the organics may increase, especially shortly after powering the OLED. At constant current control, this may result in a change in voltage.

Example of voltage evolution after a cold start at different ambient temperature levels is shown in Figure 8. The initial voltage drop is due to the device heating up until steady state (approx. min after turning on). Besides this the voltage/organic temperature depends on the ambient temperature.

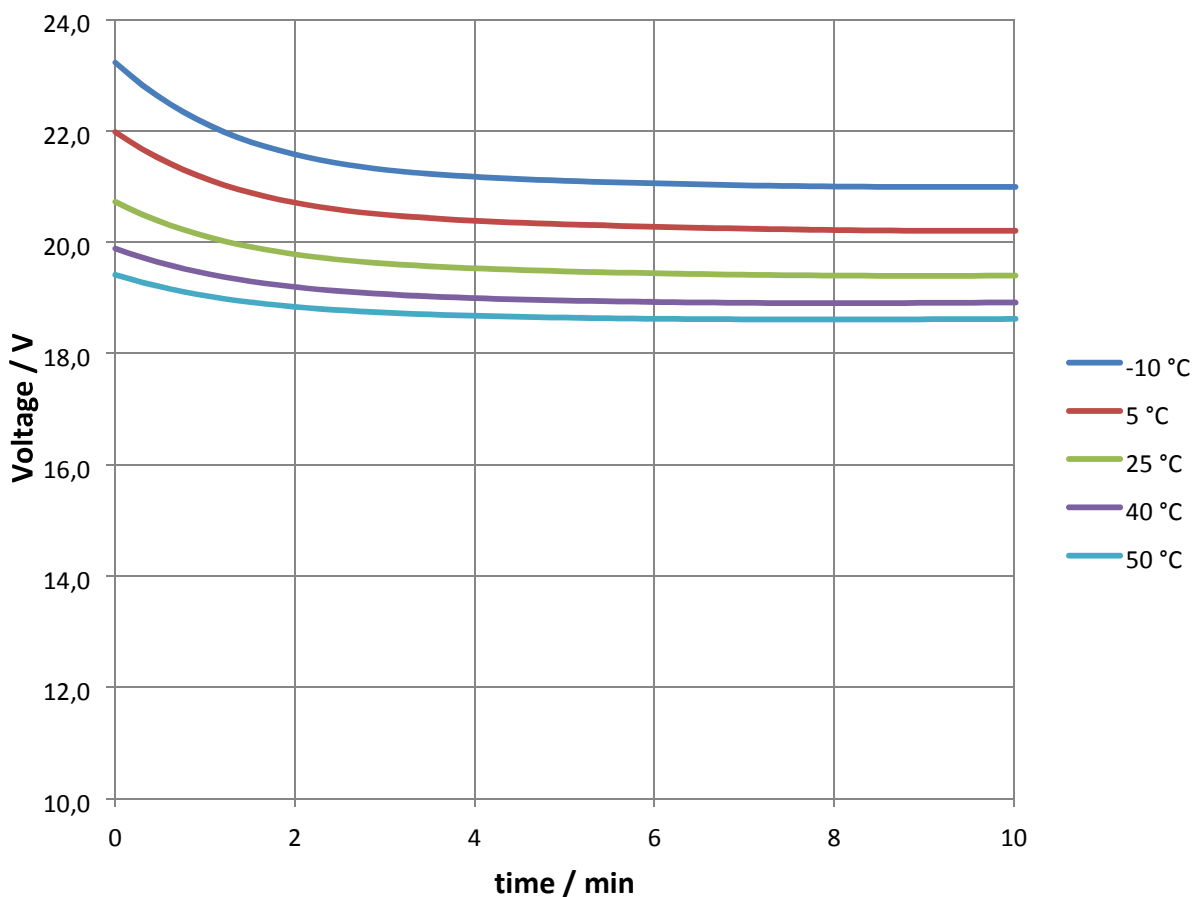

Figure 8: typical voltage evolution after start-up at different ambient temperatures, integration level I, vertical orientation, air, $I_{in rated} = 0.368 A$

Figure 9 shows typical decrease of the driving voltage of the Brite FL300 after a cold start until steady state conditions when operated at different ambient temperature conditions ranging from 5 °C to 40 °C. In this example the device is driven at rated current. Electrical steady state conditions are typically reached after 5 min of operation at rated current. Typical drop down voltage after turn on at room temperature (RT = 25 °C) and rated current is 1.3 ± 0.4 V (integration level I vertically oriented in air at rated current).

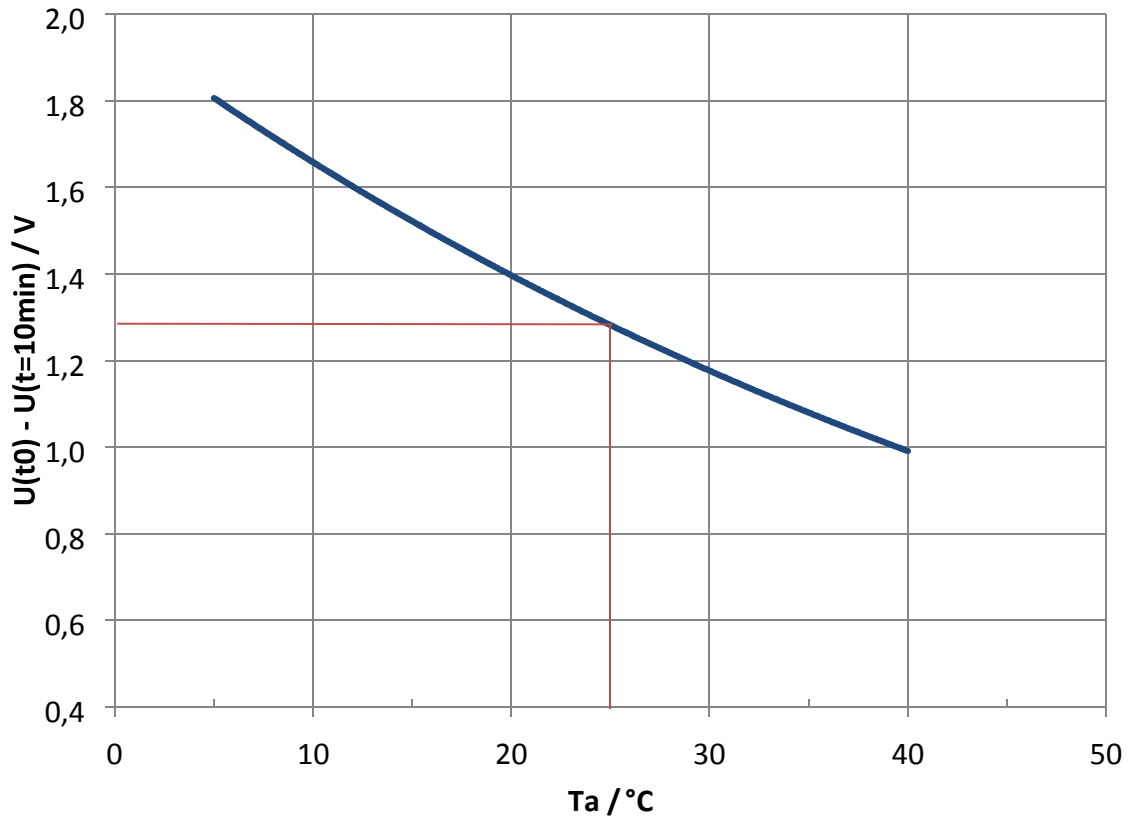

Figure 9: Voltage differences between turning device on and after 10 min at different ambient temperatures T_a , integration level I, vertical orientation, air, $I_{in\ rated} = 0.368$ A

Figure 10 gives the voltage offset that results from varying the ambient temperature T_a with respect to $RT = 25\text{ }^\circ\text{C}$. Two curves are given, one for steady state condition and one for the turn on condition.

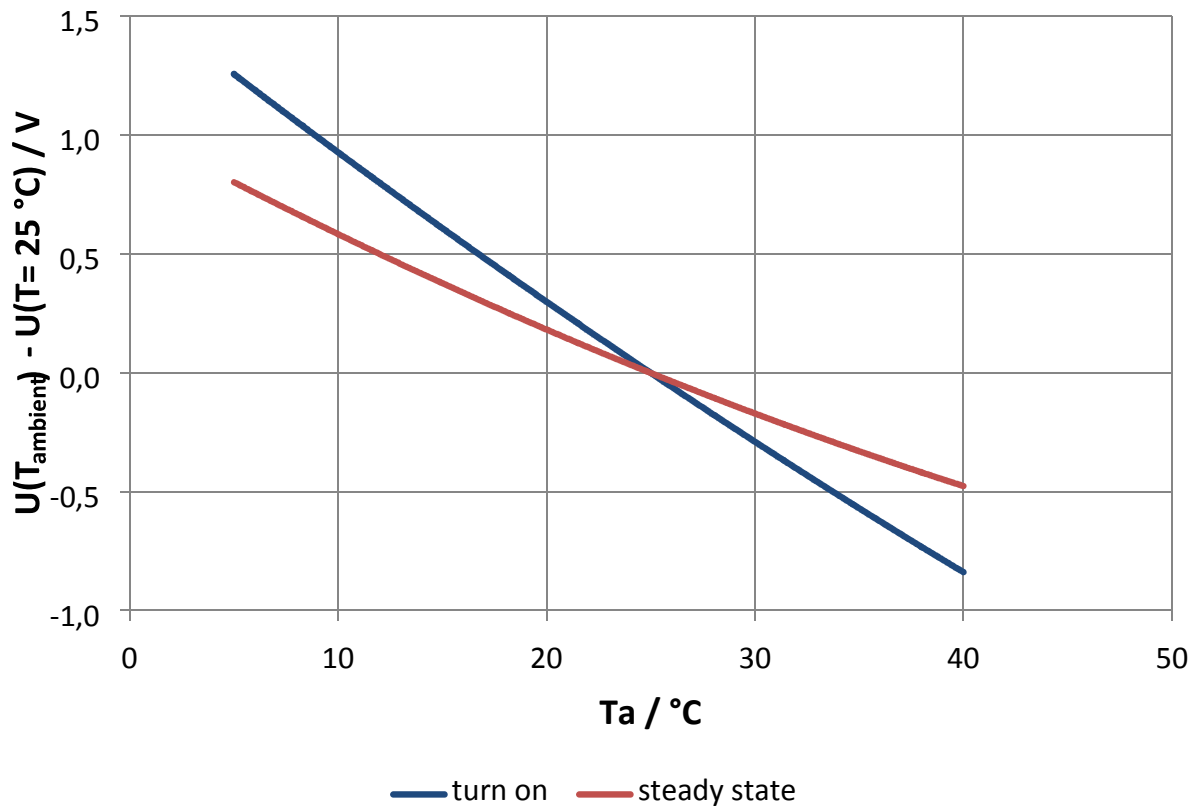

Figure 10: impact of ambient temperature T_a on change of OLED voltage with respect to $RT = 25\text{ }^\circ\text{C}$,
Integration level I, vertical orientation, air, $I_{in\ rated} = 0.368\text{ A}$

Short circuit behavior

If an OLED fails it can fall into a short circuit. Such a condition may mean that

- no light is generated
- the OLED is heated locally, i.e. one small spot of the OLED surface gets hot
- the current still flows through the OLED but the voltage drops to a lower value.

In case such a fault occurs turning off the OLED is recommended.

Optical characteristics FL300 L ww*²

Specification item	Value	Unit	Condition
Luminance, nominal	8300	cd/m ²	@ I _{in rated} = 0.368 A, perpendicular, center
	3150		@ 0.135 A, perpendicular, center
Luminous flux	300 ± 10 %	lm	@ I _{in rated} = 0.368 A with L70B50 = 10khrs
	115 ± 10 %		@ 0.135 A with L70B50 = 50khrs
Luminous efficacy, nominal	42	lm/W	@ I _{in rated} = 0.368 A
	46		@ 0.135 A
	50		@ 0.040 A
Color	White		
Chromaticity x, nominal	0.4415		integral measurement, CIE 1931
Chromaticity y, nominal	0.4016		
Chromaticity u', nominal	0.2546		integral measurement, CIE 1976
Chromaticity v', nominal	0.5211		
Duv	-0.0016		center of color box with respect to BBL
Color spec limits CIE xy	0.4290 0.3934		corner coordinates of area in colorspace
	0.4490 0.3997		
	0.4544 0.4097		
	0.4337 0.4034		
Color spec limits CIE u'v'	0.2500 0.5159		corner coordinates of area in colorspace
	0.2604 0.5215		
	0.2594 0.5262		
	0.2488 0.5206		
CCT	2,900	K	@ I _{in rated} = 0.368 A
Color Rendering Index: CRI / R9	80 / 0		@ I _{in rated} = 0.368 A
color instability over angle (CSF)	≤ 0.004		0 .. 75°, □=5°, T _a = RT, I = 0.368 A
Homogeneity	≥ 80%		9 point measurement, min/max, I _{in rated} = 0.368 A

*² all data for stabilized electrical conditions of the device after 5 min warm-up period, integration level I.

OLED spectrum

Typical spectra of the OLED at different driving currents are given in Figure 15.

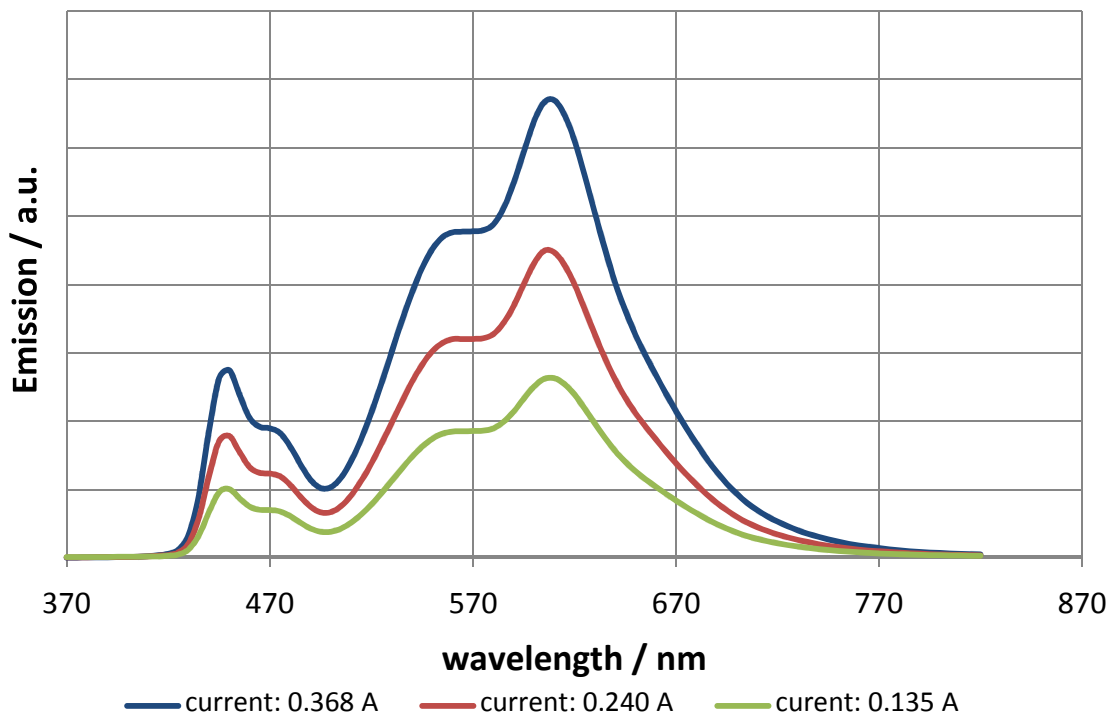

Figure 11: typical emission spectra of the Brite FL300 L ww at different driving currents ($I = 0.135\text{ A}, 0.240\text{ A}, 0.368\text{ A}$)

Current – voltage – luminance characteristics

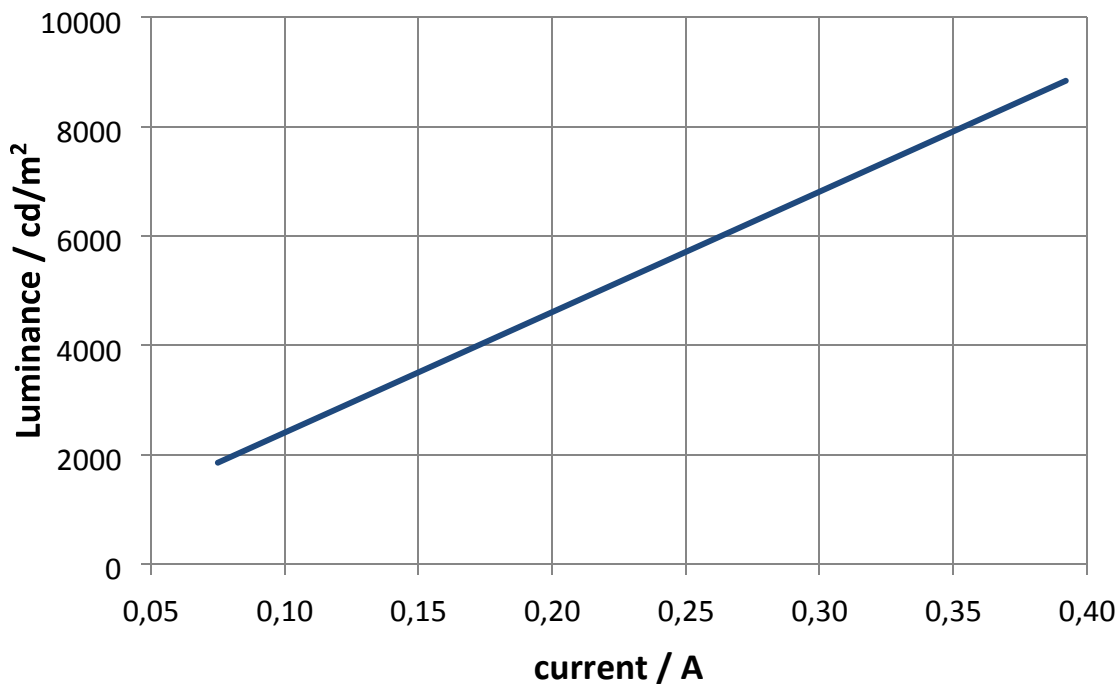

Figure 12: Luminance versus forward current at room temperature, integration level 1

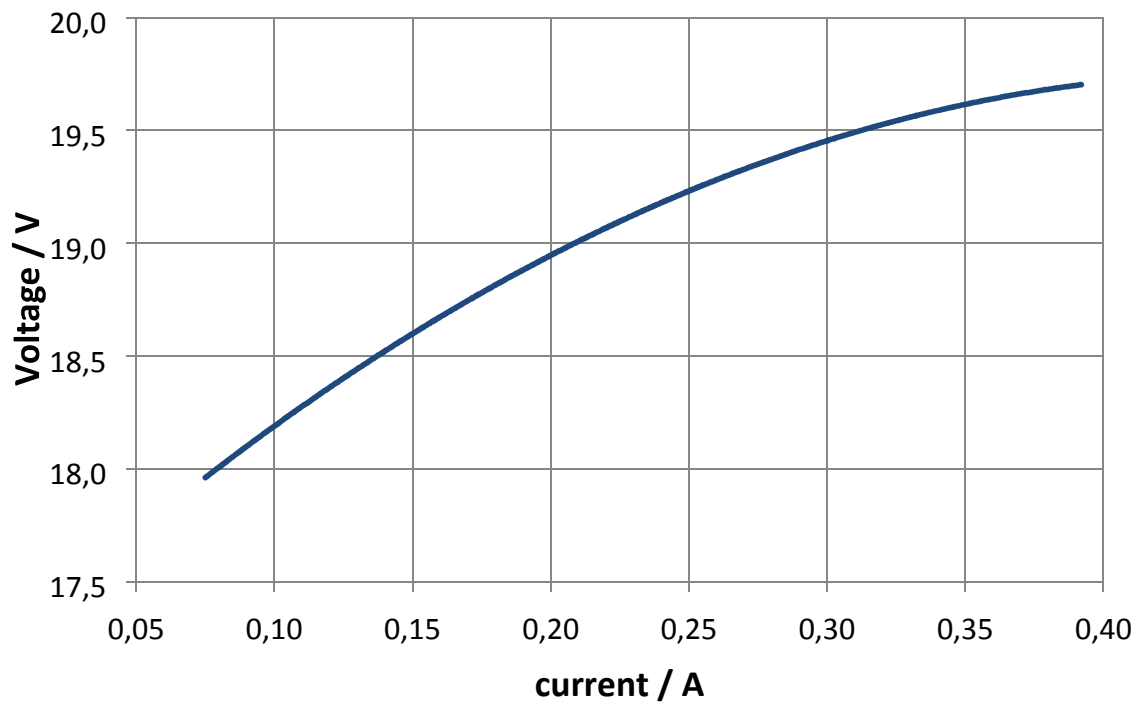

Figure 13: Voltage versus forward current at room temperature, integration level I

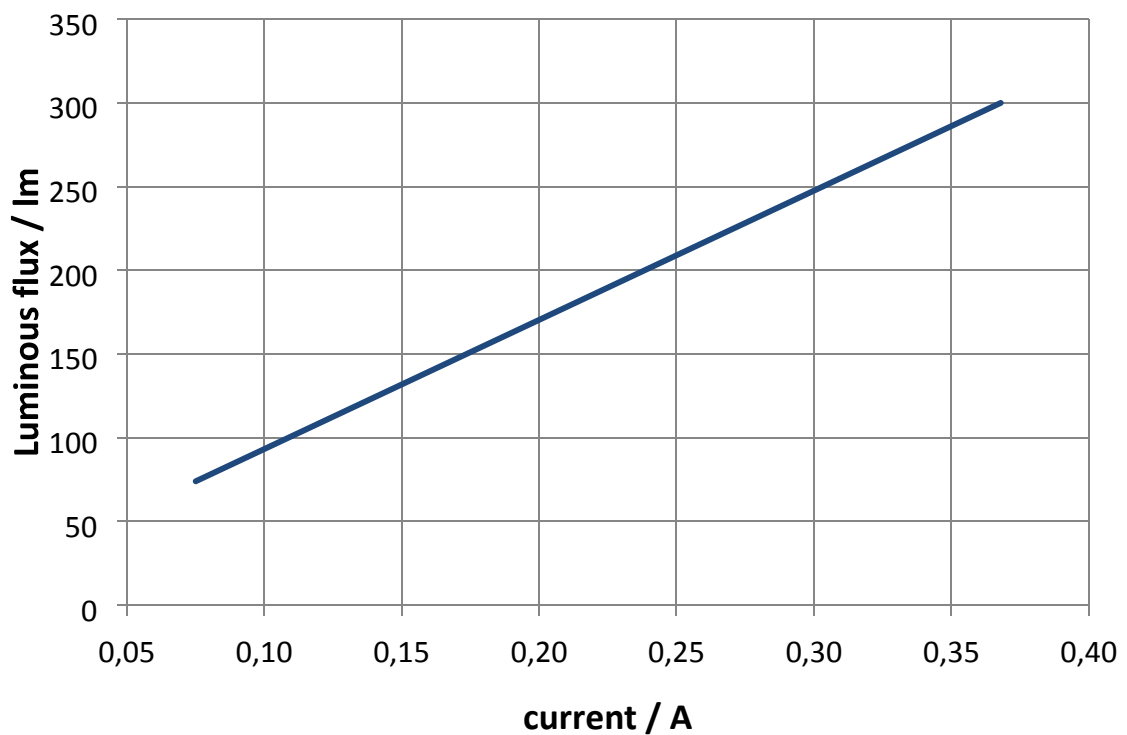

Figure 14: Luminous flux vs current, integration level I

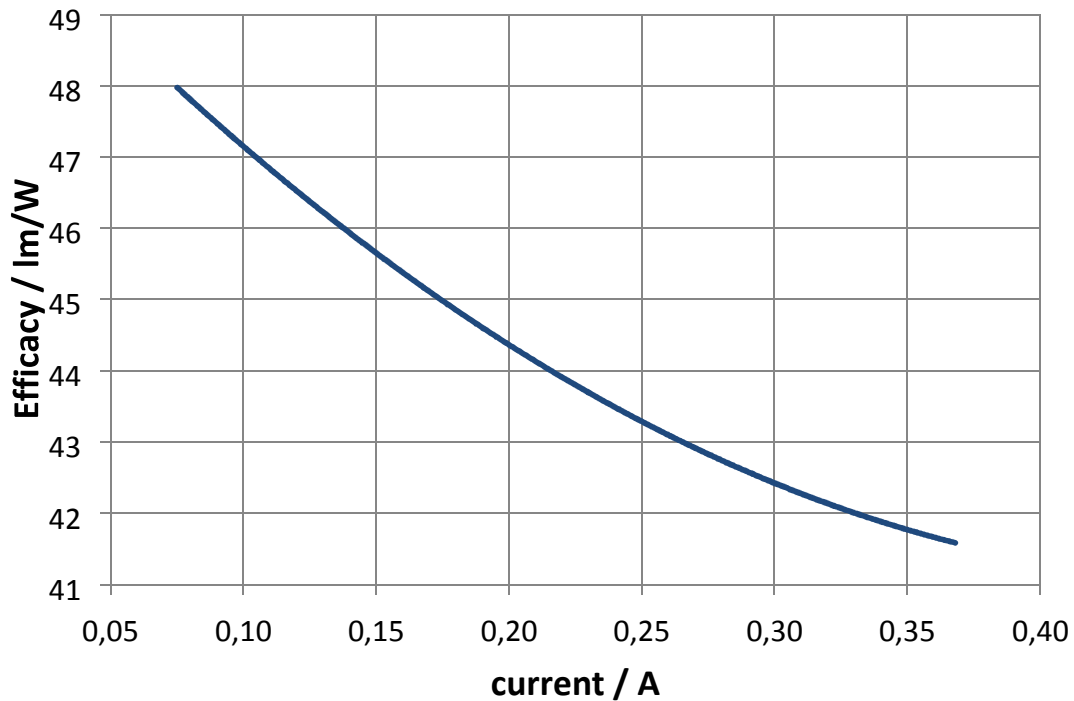

Figure 15: Efficacy versus current at room temperature, integration level 1

Homogeneity of optical parameters

The Philips Lumiblade OLED Panel Brite FL300 L is a large area device and the luminance value may depend on the location within the active area. A very small color point distribution may also be observed: Typical values for a bare OLED at rated current and room temperature are $\Delta CIE_x \approx 0.0012$, $\Delta CIE_y \approx 0.0009$ ($\Delta CIE_u' \approx 0.0016$, $\Delta CIE_v' \approx 0.0005$).

Angular dependency

The luminance (measured in cd/m^2) of the OLED light depends on angle of observation. Figure 16 shows typical values for the Philips Lumiblade OLED Panel Brite FL300 L ww N w/o Rset operated at different driving currents.

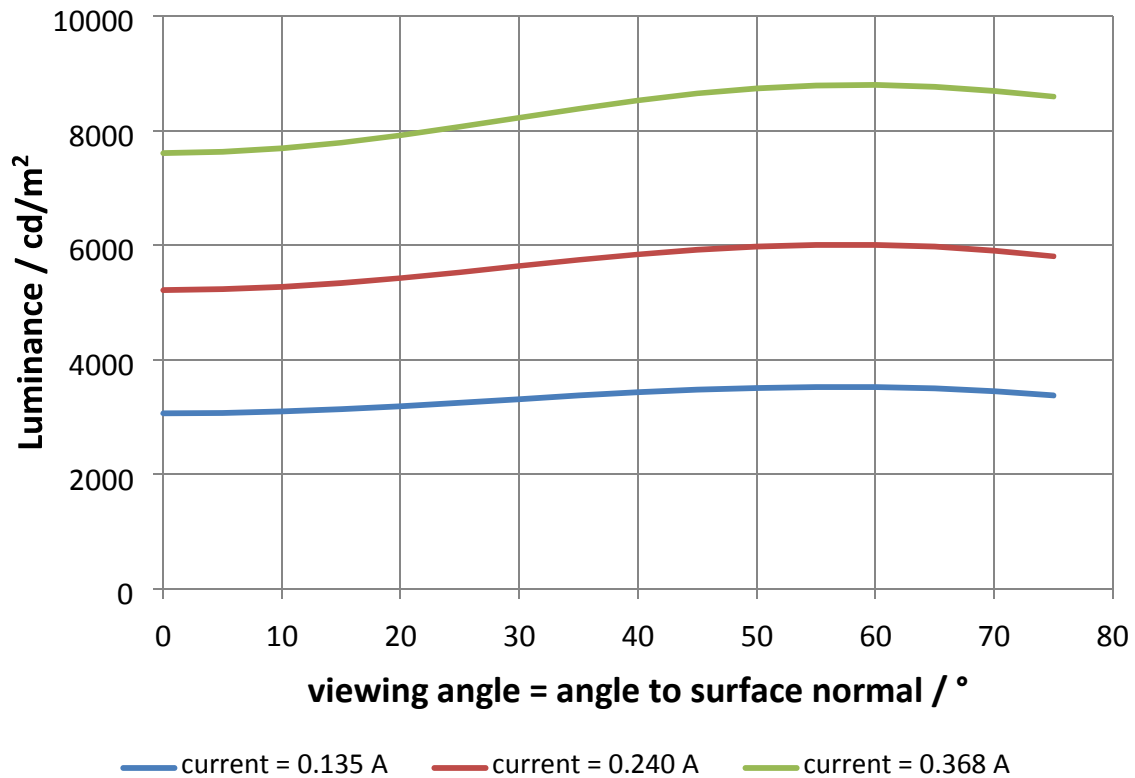

Figure 16: Luminance as function of the viewing angle. Driving currents $I = 0.135 \text{ A}$, 0.240 A , 0.368 A , FL300 L ww

Specific Optical characteristics FL300 L wm*²

Specification item	Value	Unit	Condition
Luminance, nominal	3800	cd/m^2	@ $I_{\text{in rated}} = 0.368 \text{ A}$, perpendicular, center
	1450		@ 0.135 A , perpendicular, center
Luminous flux	190	lm	@ $I_{\text{in rated}} = 0.368 \text{ A}$ / with L70B50 = 10khrs
	74		@ 0.135 A with L70B50 = 50khrs
Luminous efficacy, nominal	26	lm/W	@ $I_{\text{in rated}} = 0.368 \text{ A}$
	30		@ 0.135 A
Color	White		
CCT	2500	K	@ $I_{\text{in rated}} = 0.368 \text{ A}$
color instability over angle (CSF)	≤ 0.02		$0 \dots 75^\circ$, $\Delta = 5^\circ$, $T_a = \text{RT}$, $I = 0.368 \text{ A}$
Homogeneity	$\geq 80\%$		9 point measurement, min/max, $I_{\text{in rated}} = 0.368 \text{ A}$

*² all data for stabilized electrical conditions of the device after 5 min warm-up period, integration level 1.

Angular dependency

The luminance (measured in cd/m^2) of the OLED light depends on angle of observation. Figure 17 shows typical values for the Philips Lumiblade OLED Panel Brite FL300 L wm N w/o Rset operated at different driving currents.

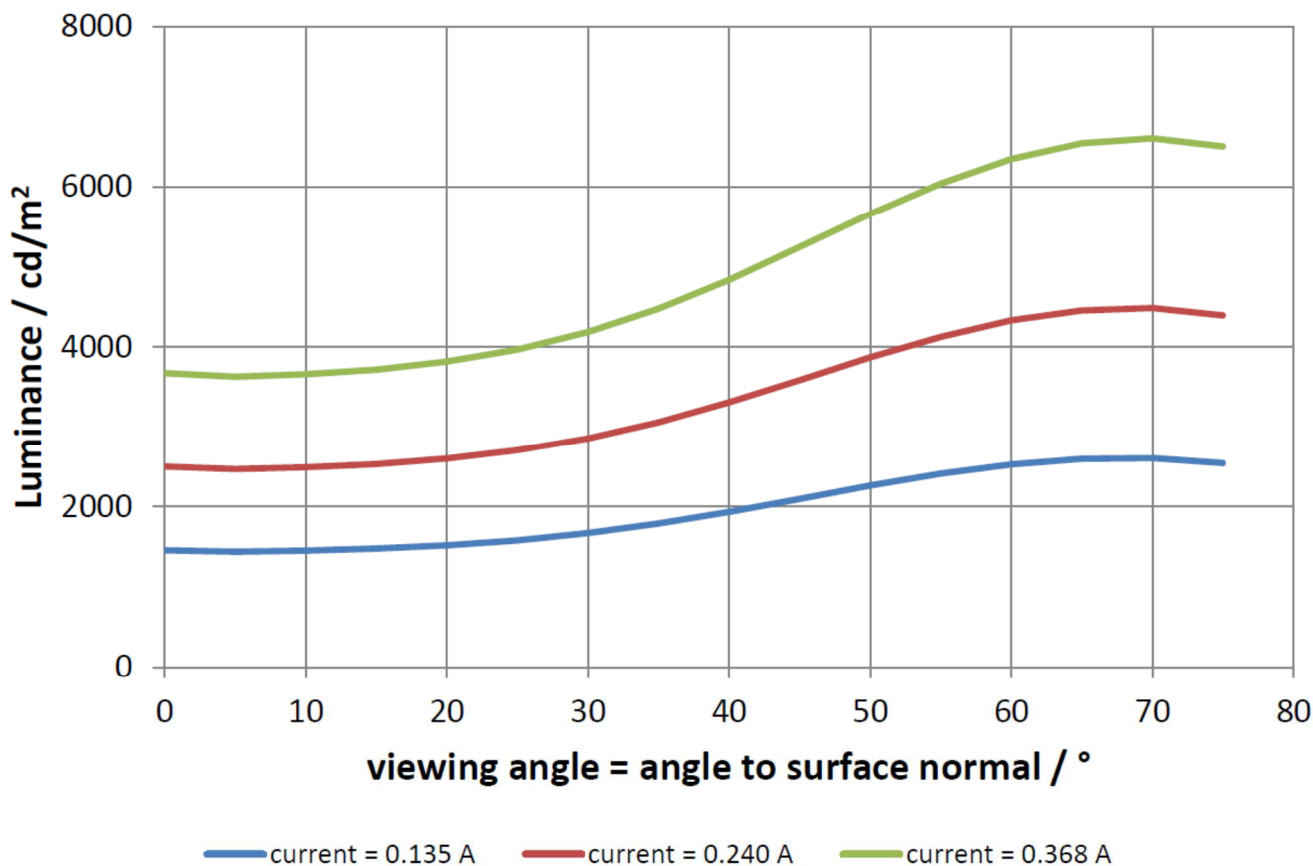

Figure 17: Luminance as function of the viewing angle. Driving currents $I = 0.135 \text{ A}$, 0.240 A , 0.368 A , FL300 L wm

THERMAL CHARACTERISTICS

OLEDs can generate a certain amount of heat. Despite the fact that no active cooling is required, the panels should not be covered in order to avoid heat accumulation.

The OLED temperature during operation depends on ambient conditions and driving current. Indicative values for internal (organics) temperature of the device can be measured at the glass surface at the center of the device with a thermocouple attached.

Typical temperature for the Brite FL300 L ww N w/o Rset is $\approx 50 \text{ }^\circ\text{C}$ with the following set-up:

- $I = I_{\text{in rated}} = 0.368 \text{ A}$
- $T_{\text{ambient}} = RT = 25 \text{ }^\circ\text{C}$
- vertical orientation
- climate chamber, no active convection.

Lifetime

Luminous flux reduces with lifetime of the OLED. The luminous flux of the Brite FL300 L decreases to approximately 70% after 10,000 hours at rated current.

Specification item	Value	Unit	Condition
OLED Panel Lifetime L70B50	10,000	Hours	@ $I_{in\ rated}$, $T_{organic} = 52\text{ °C}$
OLED Panel Lifetime L70B50	50,000	Hours	@ 0.135 A, $T_{organic} = 35\text{ °C}$

Voltage increases over lifetime of the OLED; color and homogeneity of the panel may also change.

General handling recommendations and care

Cleaning

Please avoid scratching the front side with any hard or sharp objects. OLEDs can be cleaned with any soft textile. If required use a damp cloth but avoid extensive moisture.

Use of a compressed air spray to remove regular dust from the individual panels is advised for everyday cleaning. Should fingerprints or more persistent contamination occur, isopropanol applied to a lint-free cloth can be used to gently clean the surface of the OLED. Clean using circular movements beginning at the center of the OLED and moving outwards towards the edges. Contact with water is to be avoided.

Storage and operating

Please note that the recommended storage temperature is 15 °C to 25 °C. The recommended relative storage humidity is 65% or lower. Avoid exposing OLEDs to UV light.

Safety

Please be careful when handling OLEDs. The edges of the OLED panels may be sharp and can chip or break.

In the unlikely event that an OLED fails, the temperature may rise locally to high levels. To avoid this the OLED should be turned off immediately.

Disposal

OLEDs should be disposed of according to local legislation

Logistical data

Specification item	Value
Product name	Philips Lumiblade OLED Panel Brite FL300 L ww N w/o Rset
Order code	871869653242300
Logistics code	925400013201
EAN3	8718696532430
Pieces per box	20

Specification item	Value
Product name	Philips Lumiblade OLED Panel Brite FL300 L ww A0
Order code	871869653244700
Logistics code	925400013301
EAN3	8718696532454
Pieces per box	10

Specification item	Value
Product name	Philips Lumiblade OLED Panel Brite FL300 L wm N w/o Rset
Order code	871869653238600
Logistics code	925400012901
EAN3	8718696532393
Pieces per box	20

Specification item	Value
Product name	Philips Lumiblade OLED Panel Brite FL300 L wm A0
Order code	871869653244700
Logistics code	925400013001
EAN3	8718696532416
Pieces per box	10

Contact:

OLEDWorks GmbH
 Philipsstr. 8, 52068 Aachen, Germany
info@lumiblade-experience.com

For more information visit:

www.lumiblade-experience.com
www.facebook.com/lumiblade www.twitter.com/lumiblade
www.youtube.com/user/PhilipsLumiblade



© 2014 Koninklijke Philips N.V.
 All rights reserved. Correct at 08/2014