

PHILIPS

Fortimo

LED system

SLM Gen4+
2000 lm PW L13

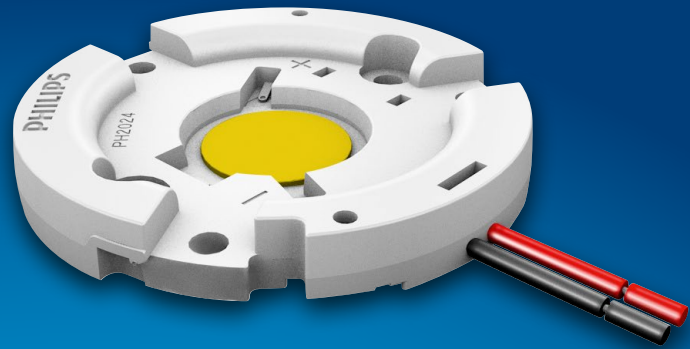

Datasheet

Experience **bright** **and vivid** colors

Fortimo LED SLM 2000 lm PW L13

The Fortimo LED SLM Gen4+ is a next generation solution for spotlight and mini-downlight applications. It is a product in line with the Fortimo brand promise of light quality and a smart system. We provide you with a system proposition ranging from 1100 lm to 4500 lm in preset outputs, with the flexibility to tune as per your needs.

Key features and benefits

- LED module efficiency of up to 140 lm/W
- Long life-time: >50,000 hours
- High color rendering: CRI >80 and CRI >90
- Excellent color consistency of 3 SDCM
- Lumen packages for 2000 lm, 3000 lm, 4500 lm (tunable in a range of ~700 - 6000 lm)
- Tunable lumen output, efficacy and lifetime
- Case temperature (Tc) upto 95 °C
- Different holder types to suit every need
- Five year system warranty



*Measurements showing compliancy to Zhaga book 3 version 1.2 have been done on the 3000 lm L15 module with the standard holder.

May 2015

This module is available in the following options. It is possible to combine these with any of the drivers as described in the design-in guide available at www.Philips.com/Technology. The nominal operating current for this module has been selected as 500 mA. Apart from this value, the module can be operated at different currents. A list of possible Rsets is provided below. More information about such tuning can be found further on in the document.

Ordering data

Commercial product name	EOC	12NC
Fortimo LED SLM 2000lm 830 PW L13 G4+	8718696 486269 00	9290 009 72906
Fortimo LED SLM 2000lm 930 PW L13 G4+	8718696 486320 00	9290 009 73206
Fortimo LED SLM 2000lm 830 DL PW L13 G4+	8718696 486283 00	9290 009 73006
Fortimo LED SLM 2000lm 930 DL PW L13 G4+	8718696 486344 00	9290 009 73306
Fortimo LED SLM 2000lm 830 PI PW L13 G4+	8718696 486306 00	9290 009 73106
Fortimo LED SLM 2000lm 930 PI PW L13 G4+	8718696 486382 00	9290 009 73406

Associated Rsets

Commercial product name	EOC	12NC	Value (Ω)	Type
Fortimo LED Rset 300mA	8718696 40193400	9290 009 12506	560	Poke-in
Fortimo LED Rset 300mA connector	8718696 40195800	9290 009 12606	560	JST
Fortimo LED Rset 500mA	8718696 40199600	9290 009 12706	1200	Poke-in
Fortimo LED Rset 500mA connector	8718696 40201600	9290 009 12806	1200	JST
Fortimo LED Rset 750 mA	8718696 40203000	9290 009 12906	2050	Poke-in
Fortimo LED Rset 750 mA connector	8718696 40205400	9290 009 13006	2050	JST
Fortimo LED Rset 950 mA	8718696 40207800	9290 009 13106	3090	Poke-in
Fortimo LED Rset 950 mA connector	8718696 40209200	9290 009 13206	3090	JST
Fortimo LED Rset 1200 mA	8718696 40211500	9290 009 13306	4870	Poke-in
Fortimo LED Rset 1200 mA connector	8718696 40213900	9290 009 13406	4870	JST

Drive currents and case temperatures

Parameter	Nominal*	Life**	Max***	Unit
I (current through the LED module)	500	500	1050	mA
Tc (case temperature at Tc point)	85	85	95	°C

* Nominal value at which typical performance is specified.

** Value at which lifetime is specified.

*** Maximum value for safe operation; do not operate above this value.

Optical characteristics - table per color (CCT)

Fortimo LED SLM 2000 lm 830 PW L13 G4+ (including DL/PI holders)

Parameter	Min	Typ	Max	Unit
Correlated color temperature (CCT) range		3000		K
Color coordinates (CIEx, CIEy)		(0.422, 0.386)		-
CRI		82		-
Energy efficiency label		A++		
Radiation angle		115		deg

Color consistency of 3 SDCM, averaged over the module.
Tolerance of ± 0.005 on x, y coordinates

Operation point	830	lm	lm/W
80% I-nom 400 mA	Tc 65 °C	1840	133
	Tc-nom 85 °C	1790	131
	Tc-max 95 °C	1760	129
I-nom = I - life 500 mA	Tc 65 °C	2240	128
	Tc-nom 85 °C	2160	124
	Tc-max 95 °C	2110	122
I-max 1050 mA	Tc 65 °C	4050	101
	Tc-nom 85 °C	3850	97
	Tc-max 95 °C	3730	94

Tolerance for flux data is $\pm 10\%$.
Tolerance for Vf data is $\pm 10\%$.
Tolerance for efficacy data is dependent on the above mentioned tolerances.
Please refer to the warranty window to ensure that your operating conditions are covered.

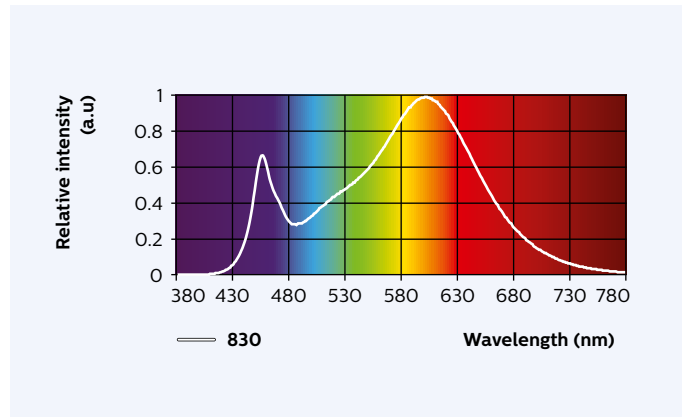

Ri	R1	R2	R3	R4	R5	R6	R7	R8	R9	R10	R11	R12	R13	R14
82	83	95	91	79	84	93	80	59	11	89	78	76	87	96

Fortimo LED SLM 2000 lm 930 PW L13 G4+ (including DL/PI holders)

Parameter	Min	Typ	Max	Unit
Correlated color temperature (CCT) range		3000		K
Color coordinates (CIEx, CIEy)		(0.422, 0.386)		-
CRI		92		-
Energy efficiency label		A+		
Radiation angle		115		deg

Color consistency of 3 SDCM, averaged over the module.
Tolerance of ± 0.005 on x, y coordinates

Operation point	835	lm	lm/W
80% I-nom 400 mA	Tc 65 °C	1600	116
	Tc-nom 85 °C	1550	114
	Tc-max 95 °C	1530	112
I-nom = I - life 500 mA	Tc 65 °C	1940	111
	Tc-nom 85 °C	1870	108
	Tc-max 95 °C	1830	106
I-max 1050 mA	Tc 65 °C	3520	88
	Tc-nom 85 °C	3340	84
	Tc-max 95 °C	3240	82

Tolerance for flux data is $\pm 10\%$.
Tolerance for Vf data is $\pm 10\%$.
Tolerances for efficacy data is dependent on the above mentioned tolerances.
Please refer to the warranty window to ensure that your operating conditions are covered.

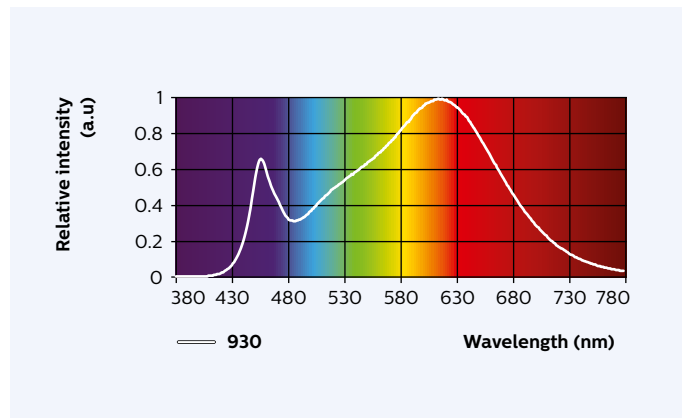

Ri	R1	R2	R3	R4	R5	R6	R7	R8	R9	R10	R11	R12	R13	R14
92	94	99	95	90	94	95	88	79	58	97	90	81	96	99

Beam shape

The Philips LED module generates a Lambertian beam shape, which is a pragmatic starting point for OEMs wishing to design secondary optics.

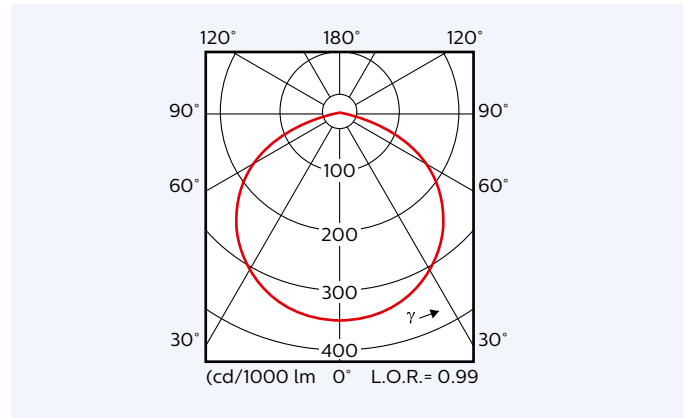

Electrical characteristics

Parameter	Min	Typ	Max	Unit
Nominal current		500	1050	mA
Forward voltage		34,7	37,2	V
Power consumption		17,4	18,6	W

Specifications stated at Tc-nom and I-nom

Lifetime

Operation point	Lifetime x 1000 hours	L70			L80			L90		
		B50	B20	B10	B50	B20	B10	B50	B20	B10
80% I-nom 400 mA	Tc 65 °C	>50	>50	>50	>50	>50	>50	>50	>50	>50
	Tc-nom 85 °C	>50	>50	40	48	31	25	23	15	12
	Tc-max 95 °C	39	26	21	25	16	13	12	8	6
I-nom = I - life 500 mA	Tc 65 °C	>50	>50	>50	>50	>50	>50	>50	46	37
	Tc-nom 85 °C	>50	38	30	36	24	19	17	11	9
	Tc-max 95 °C	30	20	16	19	12	10	9	6	5
I-max 1050 mA	Tc 65 °C	39	26	21	25	16	13	12	8	6
	Tc-nom 85 °C									
	Tc-max 95 °C									

Please refer to the warranty window to ensure that your operating conditions are covered.

Parameter	Min	Typ	Max	Unit
$\Delta u'v'$ at 6000 hours				-

Specifications stated while Tc < Tc-life and I < I-life

Absolute maximum ratings

Parameter	Min	Typ	Max	Unit
Current through the LED module (I-max)			1050	mA
Case temperature (Tc-max)			95	°C
Power at rated Tc-max and I-max			39,7	W
ESD Human Body Model (HBM) Class 3A JESD22-A114-E 8 kV			8	kV
ESD Machine Model (MM) Class B JESD22-A115-B			400	kV
Ambient temperature	-20		40	°C
Storage temperature	-40		80	°C

Wiring

Specification item	Value	Unit	Condition
Input wire cross-section (for Poke-in holder)	0.35-0.75	mm ²	solid, fused and stranded
	18-22	AWG	

Mechanical characteristics

Standard version

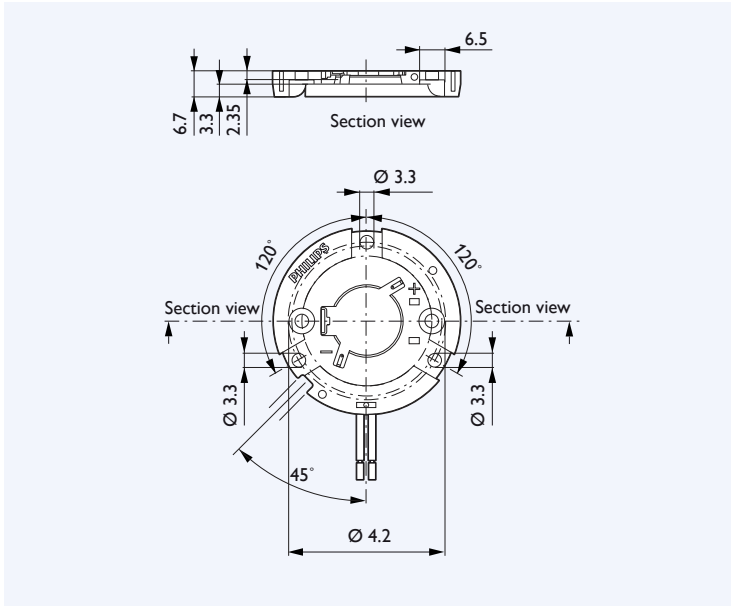

Poke-in version

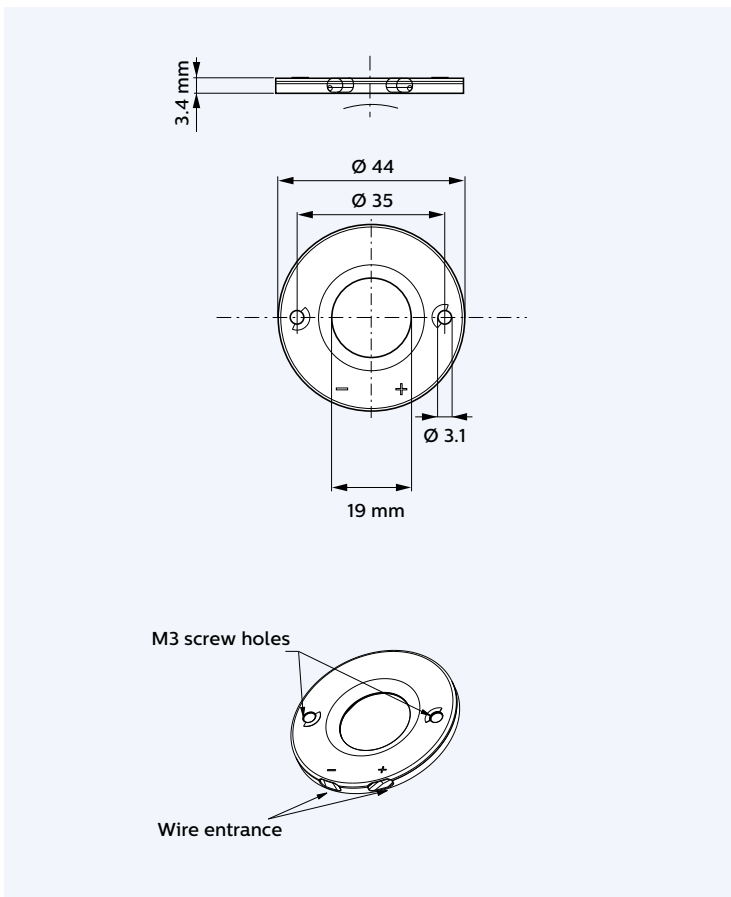

Application information

Compliance and approval

IEC / EN 62031, IEC / EN 62471

Environmental

RoHS/REACH

Photobiological safety

Item	Result: Risk group
Actinic UV	Exempt
Near-UV	Exempt
Retinal Blue Light	Risk Group 1
Retinal thermal	Exempt
Infrared Eye	Exempt
Thermal skin	Pass

Environmental

RoHS/REACH

Zhaga	Compliant*
-------	------------

*Measurements showing compliancy to Zhaga book 3 version 1.2 have been done on the 3000 lm L15 module with the standard holder.

IP rating	No IP Rating
Overheating protection	No Protection

Tuning information

Flux and efficacy versus current (at $T_c = 85\text{ }^\circ\text{C}$)

I [mA]	Flux [%]	Efficacy [%]
150	34%	119%
200	44%	117%
250	55%	115%
300	64%	111%
500	100%	100%
750	138%	89%
950	165%	81%
1050	178%	78%

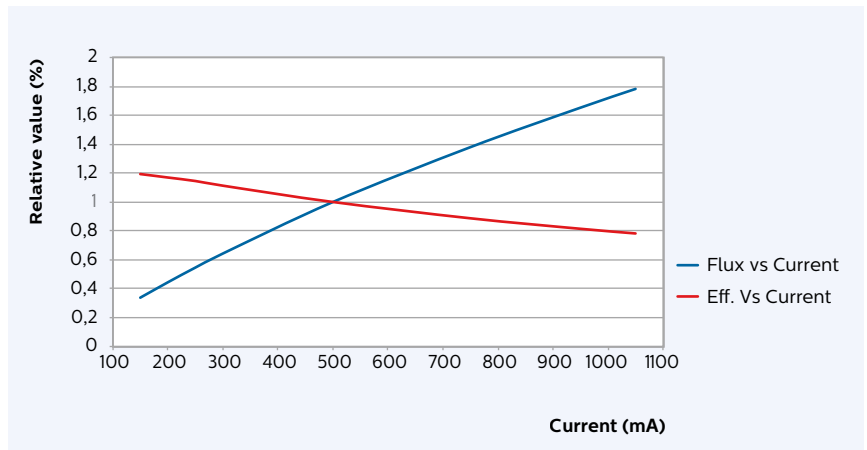

Flux and efficacy versus temperature at T_c (at I = 500 mA)

T_c [$^\circ\text{C}$]	Flux [%]	Efficacy [%]
95	98%	98%
85	100%	100%
75	102%	102%
65	104%	103%
55	105%	104%

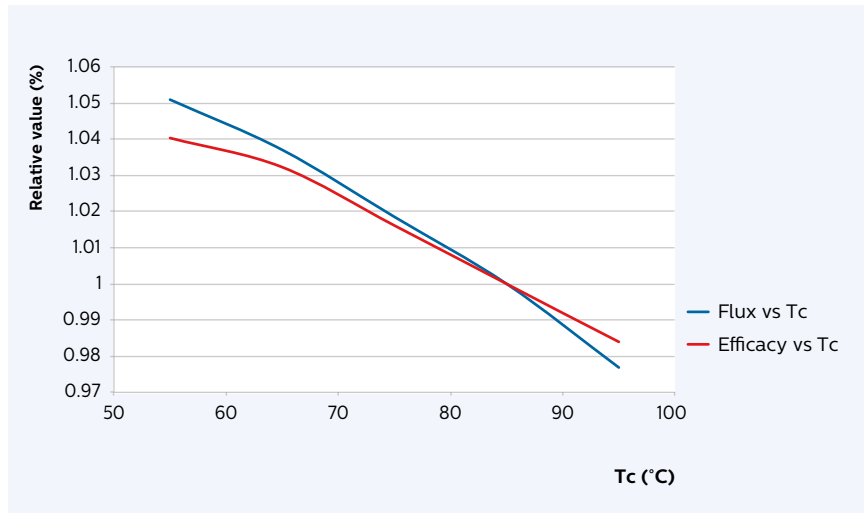

Warranty Window

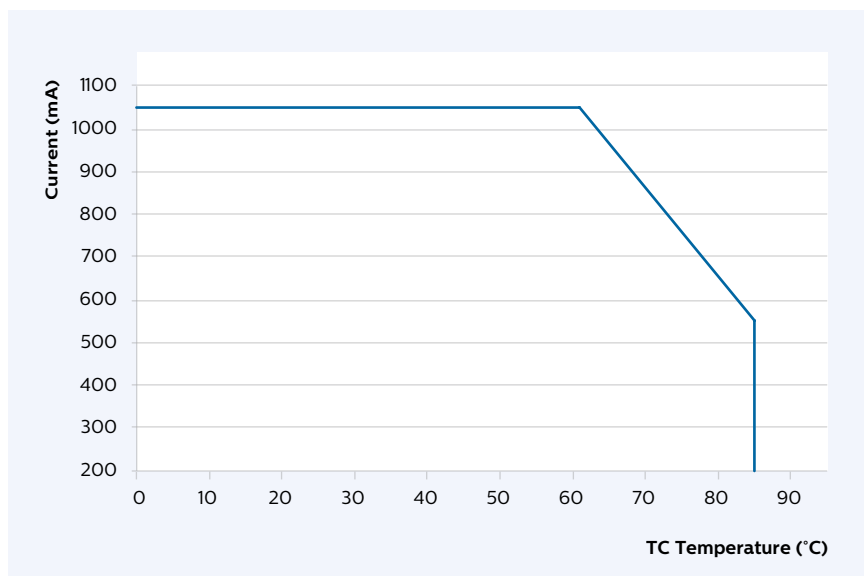

Lumen maintenance

Lumen maintenance at I-life and Tc-life conditions

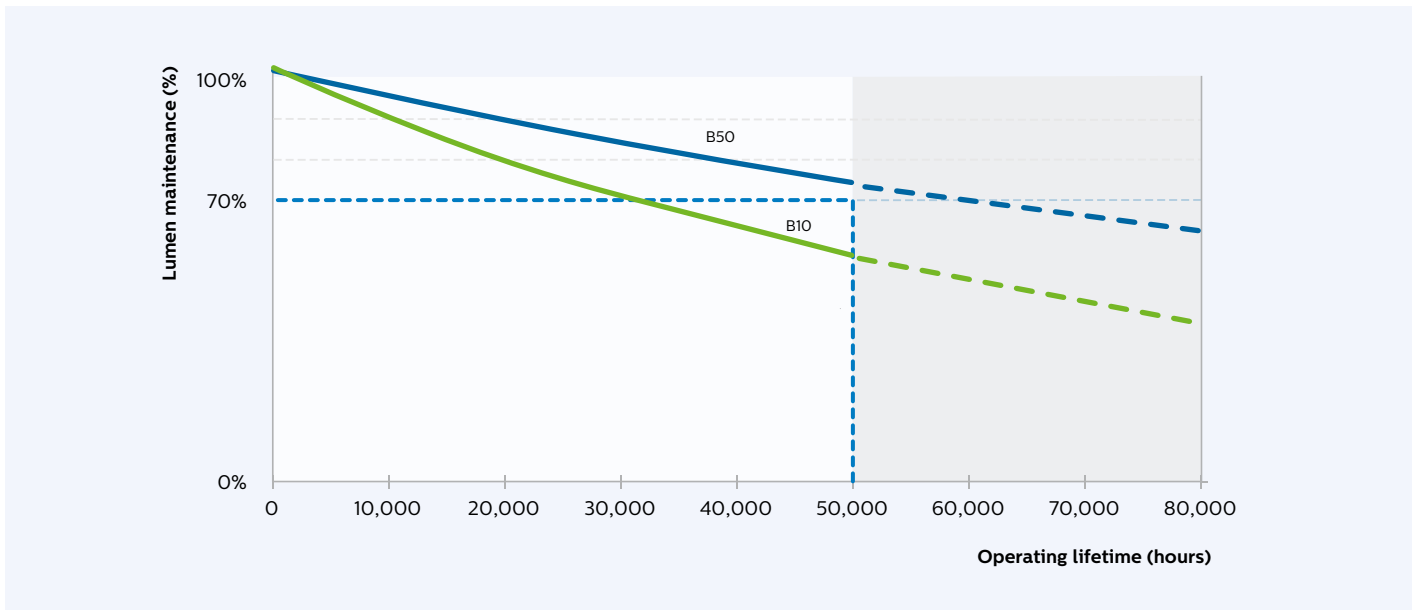

Lumen depreciation as a function of operating hours for I-life and Tc-life.

Lumen maintenance for B50 at current I-life conditions

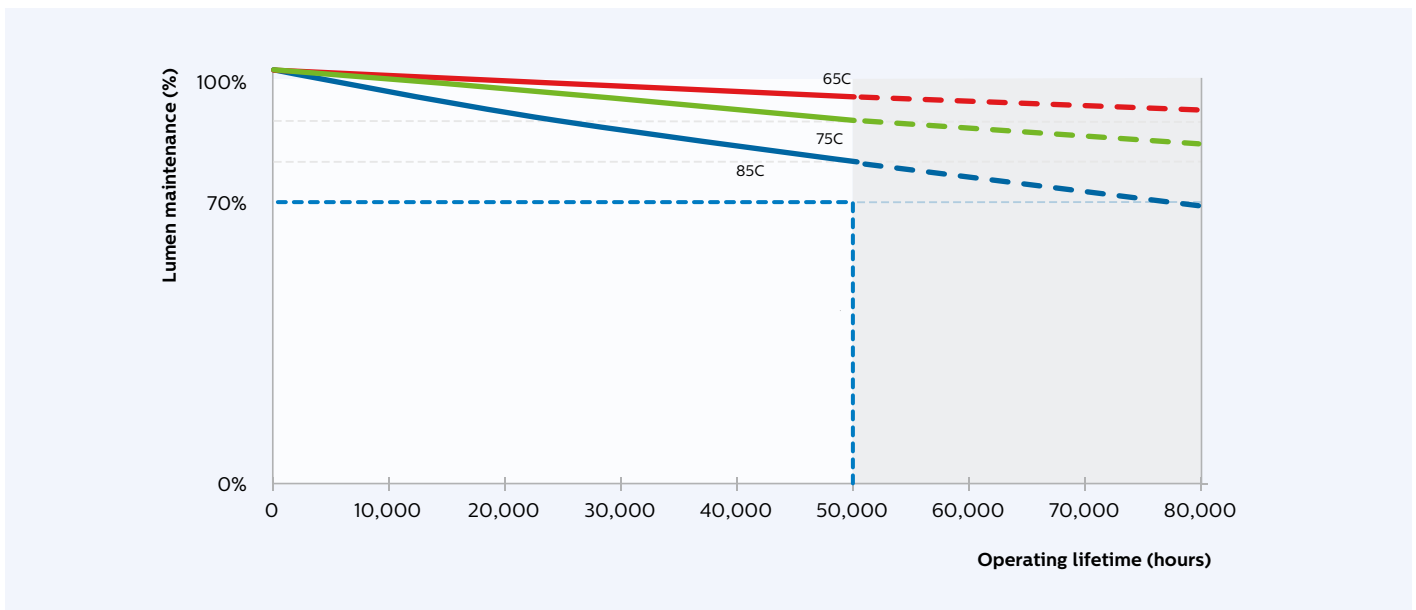

Lumen depreciation as a function of operating hours at different Tc values and I-life.



© 2015 Koninklijke Philips N.V. All rights reserved. Philips reserves the right to make changes in specifications and/or to discontinue any product at any time without notice or obligation and will not be liable for any consequences resulting from the use of this publication.

www.philips.com/technology

05/2015
Data subject to change.