



Design-in guide

Philips Xitanium programmable LED drivers

March 2014

PHILIPS
sense and simplicity

1. Contents

1. Contents	
2. Introduction to this guide	1
2.1. Information or support	1
3. Safety precautions	2
4. Introduction to Xitanium programmable LED drivers	3
4.1. Application note	3
4.2. Explanation of the commercial naming of the Xitanium programmable LED drivers	3
5. Features of Xitanium programmable LED drivers	4
5.1. Driver wiring	4
5.2. Driver output current	4
5.3. Adjustable Output Current (AOC)	5
5.4. Operating window	6
5.5. Constant Light Output (CLO)	6
5.6. Driver operating hours	6
5.7. End of Life (EOL)	7
5.8. Adjustable Startup Time	7
6. Thermal management	8
6.1. Module Temperature Protection (MTP)	8
6.2. Thermal Fold Back (TFB) of driver	9
6.3. Temperature Case Point	9
6.4. Reliability and failure rate	10
6.5. MTTF Predictions	11
7. Integrated dimming protocols	12
7.1. 1-10V Dimming	12
7.2. DALI	12
7.3. Integrated Dynadimmer	13
7.4. Dynadimmer Override	13
7.5. AmpDim	14
7.6. LineSwitch	14
8. Inrush current	16
9. Surge protection	16
10. Leakage current	16
11. Electromagnetic compatibility (EMC)	17
12. Electrical isolation	17
13. DC emergency operation	18
14. Programming	18
14.1. Programming time	19
14.2. Profiles	19
15. Integrated Dynadimmer settings	19
15.1. Synchronising changes to ON-Time duration	19
15.2. Settings change: More than 1 hr difference	19
15.3. Settings change: Less than 1 hr difference	20
15.4. Input mains power interruption	20
15.5. Input mains power dip	20
15.6. Input Mains Power OFF for maintenance or temporary power outage	20
15.7. Programming a new dimming schedule	20

2. Introduction to this guide

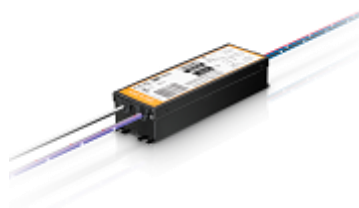

Thank you for choosing the Philips Xitanium programmable LED drivers. In this guide you will find the information you need to design these drivers into a luminaire. We advise you to consult our websites for the latest up-to-date information.

2.1. Information or support

If you require any further information or support please consult your local Philips office or visit:

- Xitanium drivers www.philips.com/xitanium
- Outdoor products www.philips.com/outdoor
- OEM general info www.philips.com/oem

Figure 1 - Xitanium Programmable LED driver 75 W / Xitanium Programmable LED driver 27W

3. Safety precautions



Warnings

- Avoid touching live parts!
- Do not use drivers with damaged wiring!

Safety warnings and instructions to be taken into account during design-in and manufacturing.

- Do not use damaged or defective contacts or housings.
- Do not service the driver when the mains voltage is connected; this includes connecting or disconnecting the LED load.
- Do not use damaged products.
- Cap off all unused wires to prevent accidental contact with the luminaire or driver housing.
- The luminaire manufacturer is responsible for its own luminaire design and has to comply with all relevant safety standards.
- The Xitanium Programmable LED driver is intended for built-in use and should not be exposed to the elements such as snow, water and ice. Exposure will lead to corrosion of the driver housing and should be avoided. It is the luminaire manufacturer's responsibility to prevent exposure.
- Design-in support is available; please contact your Philips sales representative.

4. Introduction to Xitanium programmable LED drivers



Figure 2 - Philips Xitanium Programmable LED driver F-can

4.1. Application note

Long-lasting and low maintenance, LED-based light sources are an excellent solution for outdoor environments. For optimal performance, these lighting applications require reliable drivers matching the long lifetime of the LEDs. The Philips Xitanium programmable LED drivers set new global standards for the outdoor lighting solutions. The Xitanium programmable LED drivers deliver a unique level of flexibility, with a large number of features which can be customized for an optimal solution in each and every luminaire design. Luminaire creators are able to streamline logistics without compromising on performance. With multiple choices for output current, module temperature control settings and a DALI interface, this is a truly future-proof solution. The programming will accommodate inevitable improvements in LED efficacy, removing the need to design-in a new LED driver every six months.

The remarkable energy savings and CO₂ reductions achieved with LED lighting can be further extended with dimming. Xitanium programmable LED drivers offer a full range of dimming options, with both stand-alone and network protocols. The integrated Dynadimmer functionality offers multiple dimming profiles, from a simple reduction of light during off-peak hours to a complex dimming schedule. AmpDim enables cabinet-based intelligent dimming without the need for additional control wires or infrastructure changes. The 1-10 V interface allows for simplified, one-way management, while the DALI interface makes any installation with the Xitanium programmable LED driver ready for a fully networked control system.

4.2. Explanation of the commercial naming of the Xitanium programmable LED drivers

The names of the drivers are defined as shown in the example below:

4.2.1. Xitanium 150W 1.05A Prog+ GL-H sXt

Xitanium	:	concept name for highly efficient and extremely reliable drivers
150W	:	maximum output power
1.05A	:	maximum output current
Prog	:	feature level
+	:	including AmpDim
GL	:	input voltage range
-H	:	Housing type
sXt	:	LED Xtreme standard: Long lifetime, robust protection against moisture, vibration and temperature extremes

5. Features of Xitanium programmable LED drivers



Figure 3 – Rset2 driver lead wire color code definition

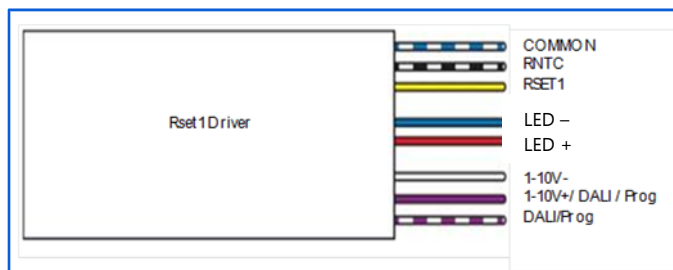

Figure 4a – Rset1 driver lead wire color code definition

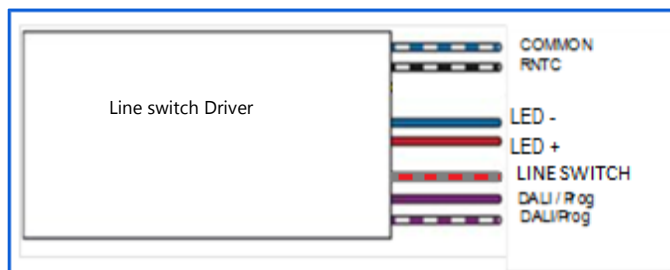

Figure 4b – Line Switch driver lead wire color code definition

5.1. Driver wiring

Driver lead wires (of these outdoor drivers) including corresponding functions are shown in Figures 3 and 4.

Important

- keep wiring between the driver and the LED module as short as possible.
- length of the control wiring COMMON, RSET1, RNTC should not exceed 60 cm.
- length of the control wiring LINE SWITCH should not exceed 56m.
- length of the LED+ and LED- wires should not exceed 10 meter, using minimum Ø 1 mm solid cable (AWG 18).

The function of each wire will be discussed further in detail in the following chapters.

5.2. Driver output current

The driver output current can be selected via the Rset resistor or with the programming interface. Xitanium programmable LED drivers use two resistor types. In all documentation, **Rset** may refer to either Rset1 or Rset2, depending on the driver type. Please check the driver datasheet for the specific resistor and corresponding current values. See Figures 5 and 6 for resistor value/output current curves.

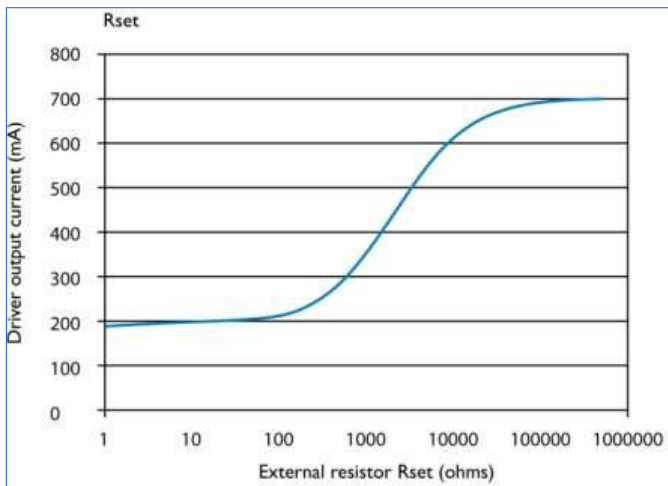

Figure 5 - Rset1 curve

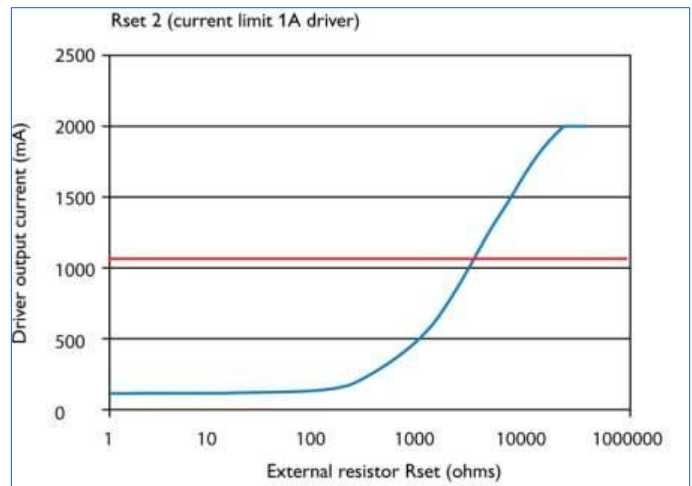

Figure 6 - Rset 2 curve

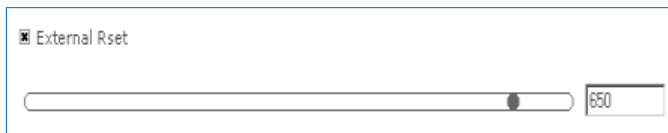

Figure 7 - Adjustable Output Current

5.3. Adjustable Output Current (AOC)

LED technology is rapidly evolving.

Using more efficient LEDs means the same light output can be achieved with lower currents.

At the same time, LEDs can be driven at different currents levels based on the application requirement.

Typically, LED drivers are available in discrete current levels e.g. 350 mA, 530 mA or 700 mA.

It is often necessary to replace a driver when more efficient LEDs become available.

The AOC feature enables OEMs to adjust the nominal output current of the driver. This can be achieved in two ways:

1. Via Rset
Placing an external resistor (min. 125 mW/50 V rated) between the RSET and COMMON wires of the driver. The driver checks the value of Rset connected either at startup or continuously for 0.5 seconds. When the resistor value is changed it is best to turn OFF and power ON again the driver to make sure that the new Rset value will take effect.

There are two different Rset conversion curves: Rset1 and Rset2. Rset2 is newer and offers a resistor range up theoretically set currents up to 2A. It can be recognized by a YELLOW/BLACK wire (Figure 4), while Rset1 has a YELLOW wire (Figure 3). If Rset is not connected, the driver will deliver its maximum specified current. For an example of the Rset curve see Figures 5 and 6. Please check the driver datasheet for the specific resistor and corresponding current values.

2. Via the MultiOne programming interface (Figure 33).

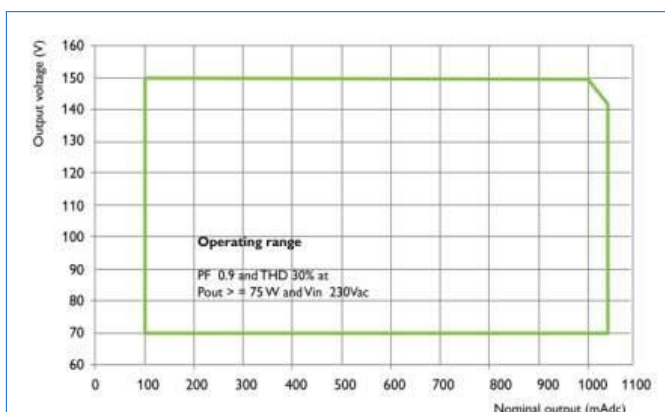

Figure 8 - Operating window

5.4. Operating window

Drivers can deliver different levels of output power, depending on driver type. For each driver there is an output current/output voltage window that has to fit the current and voltage characteristics of the connected LED PCB. The driver cannot operate beyond the specified maximum voltage and current of the operating window; neither should the driver operate below the minimum specified voltage; driver and system performance cannot be guaranteed under these conditions. See Figure 8 for an illustrated example of an operating window. Please check the driver datasheet for the specified operating window.

Note

It is possible to go below the minimum value of the specified output current, either during dimming or permanently through initial setting of the output current.



Warning

For drivers running permanently below the specified current window, it is necessary to check for compliance with respect to the IEC standards regarding mains current distortion and power

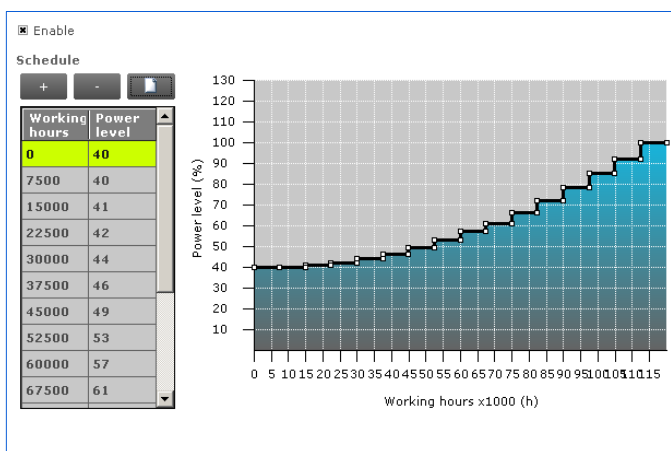

Figure 9 - Programming Constant Light Output feature

5.5. Constant Light Output (CLO)

Traditional light sources (HPS, QMH and CMH) suffer from depreciation in light output over time. This applies to LED light sources as well. The CLO feature enables LED solutions to deliver constant lumen output through the life of the light engine. Based on the type of LEDs used, heat sinking and driver current, it is possible to estimate the depreciation of light output for specific LEDs and this information can be entered into the driver. The driver counts the number of light source working hours and will increase output current based on this input to enable CLO.

When the CLO feature is enabled, the driver nominal output current will be defined by the CLO percentage as shown by the equation below:

$$\text{Driver target nominal output current} = \text{CLO percentage} \times \text{AOC}$$

For example, in the CLO profile shown in Figure 10, between 30,000-40,000 working hours, the CLO percentage is set at 115%. Assuming the nominal AOC is set to 530mA, the driver output current with CLO enabled will be $1.15 \times 530 = 610 \text{ mA}$.

The CLO percentage can be set to a value between 0-130%, in increments of 1%. A value of 0% will turn OFF the driver. The LED module working hours can be set at any value between (0-120,000 hours) in increments of 500 hours.

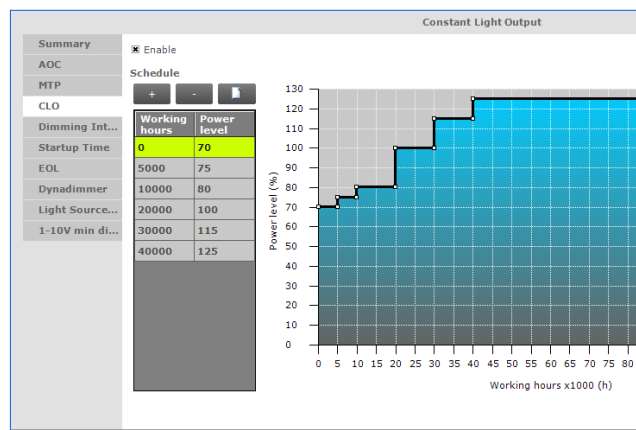

Figure 10 - Constant Light Output (CLO) profile

5.6. Driver operating hours

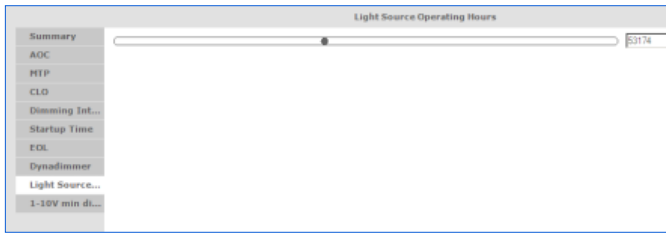

Figure 11 - Light Source Operating Hours programming

The light source operating hours recorded by the driver can be changed or reset to zero by enabling the light source operating hours feature and programming the value. When the LED module needs to be replaced with a new one, the feature can be used to reset the working hours count stored in the driver.

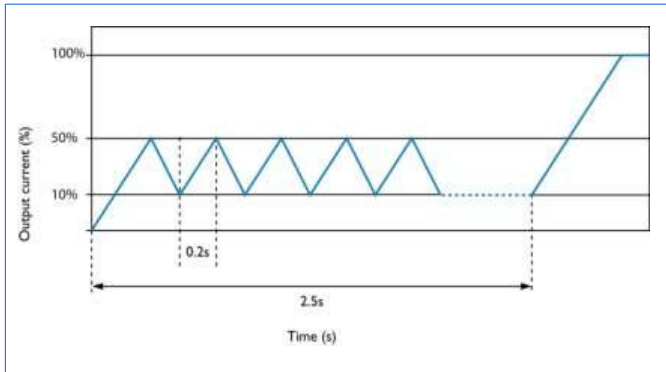

Figure 12 - EOL flashing output current waveform

5.7. End of Life (EOL)

This feature is used to signal that the LED module has reached the end of manufacturer-specified useful life and should be replaced.

The driver maintains count of the working hours of the LED light source (the same working hour count is used in the CLO feature). Using EOL, the luminaire manufacturer can define the time at which the end user is alerted to the end of life. This is known as the EOL activation time.

The EOL activation time can be set in increments of 500 hours. Once the EOL activation time is reached, the driver will flash for 2.5 seconds and then continue normal operation (Figure 12). LEDs will flash every time at startup once the module's working hours exceed the EOL activation time. Default setting has the EOL feature disabled.

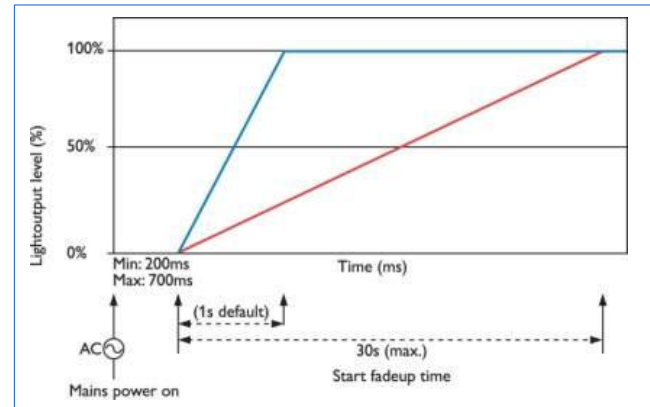

Figure 13 - Adjustable Startup Time

5.8. Adjustable Startup Time

Unlike conventional lamps, which have a ramp-up time of around 5 minutes, LED luminaires instantly offer 100% light when switched on. This effect can be disturbing in certain applications. Adjustable Startup Time feature gradually increases the light level of LEDs, ensuring a smooth and comfortable transition from daytime to evening illumination. The driver fade-up time at start-up can be programmed to a value between 1000 ms and 30000 ms, in increments of 1 ms.

The default startup time is 1000 ms.

6. Thermal management

The following section covers the critical thermal management points to facilitate design-in. Taking thermal points into account will ensure the optimum performance and lifetime of a LED system. If the Tc life of the driver is exceeded, the lifetime will be adversely affected. Please refer to individual product datasheets for specific values. Philips Xitanium programmable LED drivers are designed to provide a lifetime of up to 100,000 hours at the specified Tc life with minimum 90% survivors.

6.1. Module Temperature Protection (MTP)

This feature helps to protect the LEDs when operated in a hot ambient environment. The driver helps to regulate LED module temperature by regulating current. An NTC (Negative Temperature Coefficient resistor) must be present on the LED module and connected to BLACK/WHITE and BLUE/WHITE wires of the driver in order to use this feature. Two specific NTC part numbers are supported by this driver, while the third option enables correct operation in combination with Philips LED modules

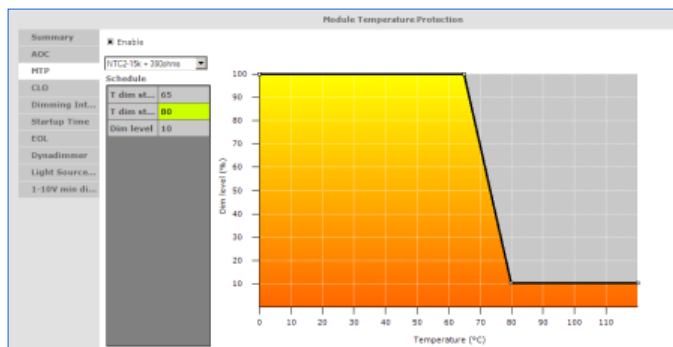

Figure 14 - Module Temperature Protection

1. 10 k NTC - Murata 10 k
Part number NCP18XH103J03RB
2. 15 k NTC - Murata 15 k
Part number NCP15XW153E03RC (with a separate 390 ohm resistor in series with the NTC)
3. Philips LED light engines

It is possible to set the temperature at which MTP feature is activated, defined by MTP warn and the slope, defined by MTP max (Figure 14). Default values are driver specific and listed in the driver datasheet. Depending on module temperature, the driver current will follow the linear line between 100 % and MTP min dim level (default 10%). At the rated operating conditions of the luminaire, the LED module temperature should not exceed MTP warn.

The MTP feature is helpful in maintaining LED life during occasional/temporary heat spikes like a hot day or loss of air conditioning. The driver responds dynamically to changes in parameters of MTP warn, MTP max and MTP min dim levels. There is no need to reset power to the driver for changes in these parameters to take effect.

By selecting option 3, the values of MTP warn and MTP max cannot be changed. They are predefined by the module specification. For details please check the corresponding Philips LED light engine datasheet.

If the 10 k NTC is selected, the driver offers an additional feature to detect if the NTC is missing from the LED module. If Module Temperature Protection is enabled and the NTC is missing, the driver will flash for 10 seconds at startup and then go to the lowest dim level (10 %).

Note: This feature is not available with option 2 (15 k NTC) and option 3 (Philips LED light engines).

6.2. Thermal Fold Back (TFB) of driver

The driver will reduce the current to the LED module if the driver itself is overheating. The driver will limit the current when the driver case temperature exceeds the maximum specified temperature by maximum 5° C. Refer to the individual driver datasheet for the specified fold back value (Figure 15).

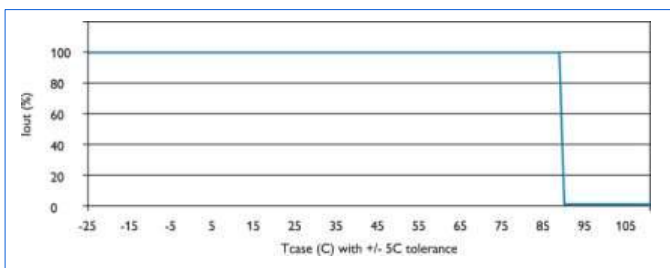

Figure 15 - Thermal Fold Back (TFB) example

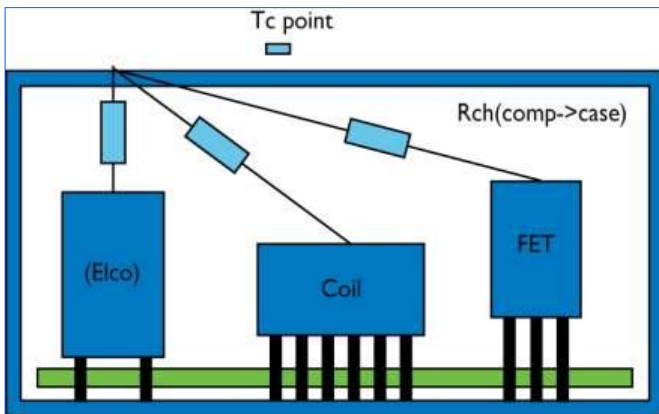

Figure 16 - Internal resistance to the driver Tc point

6.3. Temperature Case Point

To achieve optimal lifetime and reliability, it is critical that the temperature of the components in the driver remains within its rating. In the driver design, all precautions are taken to ensure that the components within the driver are at the lowest possible temperatures.

Initial thermal analysis is performed via IR scans at room temperature to identify the hottest components of the driver. Subsequently, detailed measurements of the temperatures of the critical components are performed under various input/output conditions at the worst case operating temperatures.

These temperature measurements are related to a Tcase (Tc) point on the driver as shown in Figure 16. Tc temperature is a proxy for the temperatures of the critical internal driver components.

The location of the Tc point is identified on the product label (Figure 17). Tc point on the drivers is on the side of the case at the location of pointed arrow for the F-can driver. For other housing types, the Tc point is on the dot at the end of the arrow (See red circle in Figures 18).

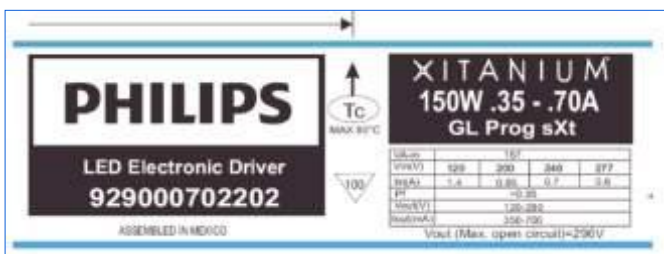

Figure 17 - Product label indicating Tc point of F-can driver



Figure 18 - Product label indicating Tc point H-can driver

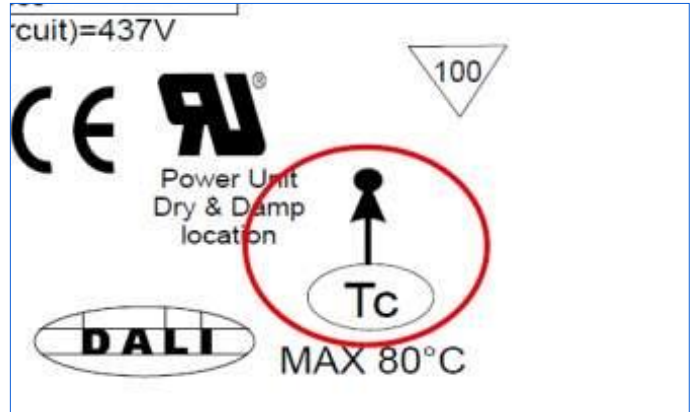

Figure 18 - Product label indicating Tc point H-can driver (detail)

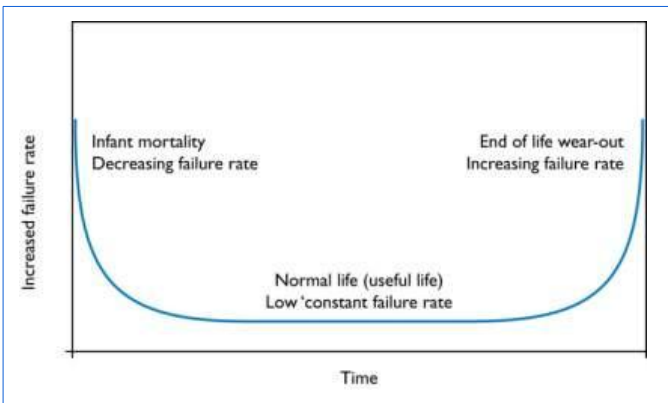

Figure 19 - Bathtub Curve

6.4. Reliability and failure rate

It is important to have a general understanding of the definitions regarding the lifetime of electronic products. Reliability experts often describe the reliability of a population of electronic products using a graphical representation known as the Bathtub Curve (Figure 19). The Bathtub Curve can be divided into three periods. The first is an initial period of infant mortality, where the defective/ weak products fail. This is followed by the normal life of the product with a low and relatively constant failure rate. Following this is the final period of the product lifetime where wear-out mechanisms of the product kick in and failure rates increase.

It is important to understand that the Bathtub Curve does not depict the failure rate of a single item, but describes the relative failure rate of an entire population of products over time. Some of the units will fail during the infant mortality period; others will last till the wear-out period while a few of the units will fail during the normal life. Reliability deals with random failures in a population of products and is expressed in terms of rates, such as Failures in Time (FIT) or Mean Time to Failure (MTTF).

MTTF is the theoretical accumulation of random statistical failures of all components in the product, expressing the "constant failure rate" over lifetime. On the other hand, lifetime refers to the length of time that a single product may be expected to function properly before a known wear-out mechanism renders the product unfit for use. Lifetime is typically expressed in hours and normally indicates the duration of time with a minimum survival rate of 90% (obtained from the MTTF calculations). For instance, a lifetime of 100,000 hours implies that under normal conditions, in a typical installation (population), 90% of the products installed would be expected to last 100,000 hours before failure.

6.5. MTF Predictions

While the lifetime of the LED driver depends on the component that is most likely to fail, the failure rate of the driver depends on all the components within the driver. The MIL-HDBK-217F reliability model is used to predict the theoretical failure rate of the Xitanium LED drivers.

As an illustration, for a typical 150W Xitanium LED driver operating at a case temperature of about 50° C, a theoretical failure rate of 500 PPM/1000 hours and a MTF value of approximately 2 million hours is obtained. Please note that for the MTF calculation, worst case electrical stresses are assumed to obtain a conservative estimate of the LED driver's MTF. If more realistic values are assumed, higher MTF values are expected. These calculations also assume a typical operating temperature. If the operating temperatures were higher, the stress levels on the driver components would increase, leading to increased failure rates. Please note that the MTF data are based on theoretical calculations only and by no means can substitute for actual field data. Past experience has shown that this theoretical prediction is much more conservative than the actual field data. Ongoing field testing indicates much higher survival. The exact driver failure rate can be found in the driver datasheet.

7. Integrated dimming protocols

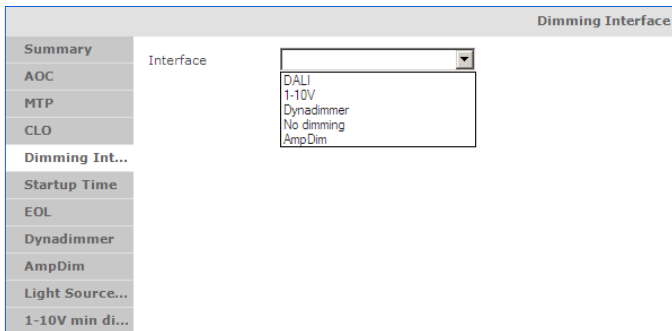

Figure 20 - Integrated dimming protocols

Xitanium programmable LED drivers offer a range of integrated dimming protocols (Figure 20). The individual dimming features and their programming are described below.

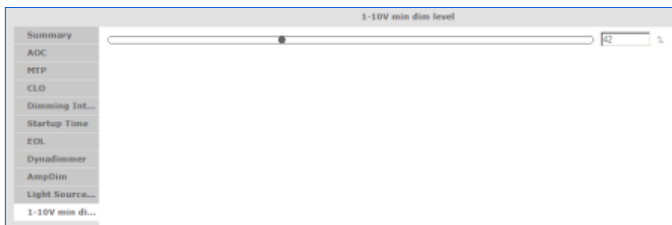

Figure 21 - Programming 1-10V dimming

7.1. 1-10V Dimming

This is the traditional way of dimming a driver between 100% and 10% based on dimming voltage, in 1% increments. Note that the 100% level is determined by the output current level, either programmed or set via external Rset (AOC feature). The minimum current that can be supplied by the driver is specified in the datasheet. The lowest possible dim level is defined by the higher of the two values: Minimum output current or 10% dim level.

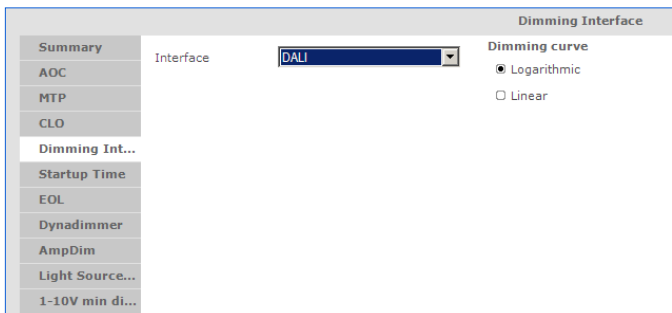

Figure 22 - Programming DALI

7.2. DALI

Digital Addressable Lighting Interface, or DALI, is a digital communication protocol popular in the lighting industry. It is an IEC standard and there are many control devices from Philips and other manufacturers that communicate using DALI. The voltage across DALI wires is typically 16 V (refer IEC specification for details) and it is polarity insensitive. The DALI wires can be run alongside input main wires and the maximum current on a DALI line is limited to 250mA. The voltage drop between two devices on a DALI network cannot be more than 2 V, resulting in a maximum length of 300 m between any two DALI components.

Using DALI, it is possible to send dimming commands (1-254 levels), set fade rates and fade times, query driver or LED status, etc. Programmable drivers also respond to LED-specific DALI commands e.g. query if the LED module is short circuit or open circuit; select between logarithmic or linear dimming curves, etc. For more information on DALI, refer to the IEC specification for DALI protocol. 1. IEC 62386: 102 – General requirements – Control gear 2. IEC 62386: 207 – Particular requirements for control gear – LED modules.

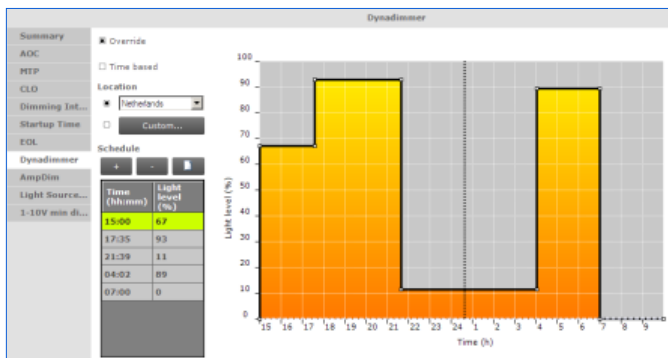

Figure 23 - Integrated Dynadimmer settings

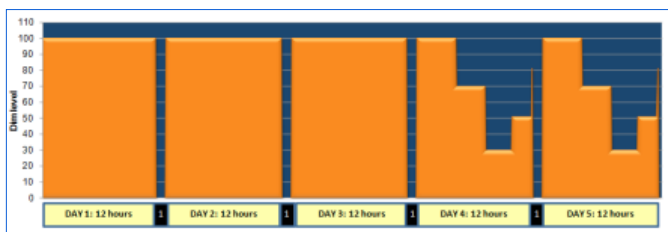

Figure 24 - Dynadimmer virtual clock setting

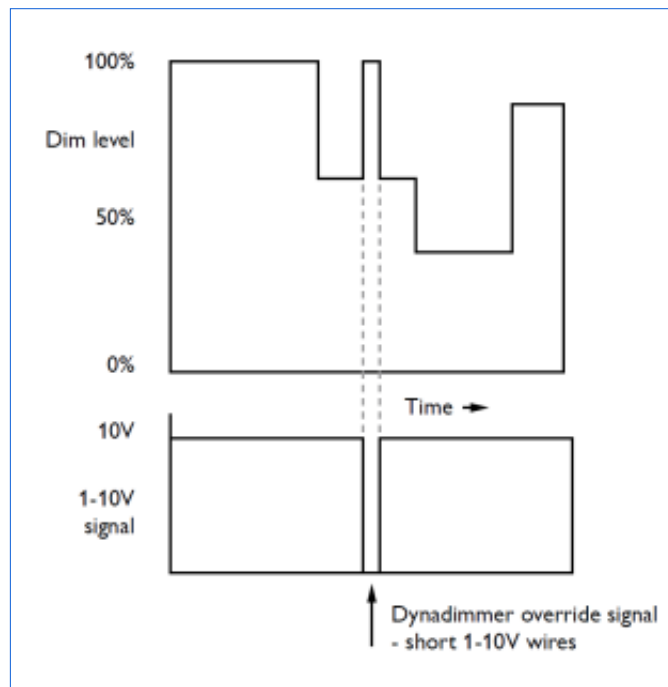

Figure 25 - Dynadimmer override signal

7.3. Integrated Dynadimmer

Dynadimmer is an external dimming control device developed by Philips that enables a simple, pre-programmed multistep dimming. Programmable drivers offer an integrated version of this feature (Figure 23).

Integrated Dynadimmer allows dimming to predefined light levels based on the nightly operating time. With flexibility in setting time and light levels, the user can configure the driver for specific locations and application needs. Using Integrated Dynadimmer, it is possible to set up to 5 dim levels and time intervals. The driver does not have a real time clock. Instead it runs a virtual clock, determined by the length of nightly operating hours. After 3 ON-OFF cycles, the driver will calculate the virtual clock time. A valid ON-time is defined as a period during which the driver operates continuously for ≥ 4 hours to ≤ 24 hours. As shown in Figure 24, after repeating the driver ON-time for 3 consecutive days, the dim profile takes effect from the 4th day onwards. For more information on Dynadimmer scenarios please refer to Chapter 15.

Newer driver types allow setting the predefined light level as low as 0% (OFF); in the near future all drivers will offer this option.

7.4. Dynadimmer Override

In some instances, there is a need to override the Dynadimmer dim cycle either manually or automatically. For example, luminaires in a parking garage may be configured to utilize the integrated Dynadimmer feature with a defined dim cycle.

A motion sensor can be associated with one or more luminaires which, when activated by passing cars, can signal the driver to override the dim cycle and go to full light output. When the Dynadimmer Override function is enabled and the 1-10 V wires are shorted, the driver will override the active dim cycle and go to full light output. The driver will return to normal Dynadimmer dim cycle when the 1-10 V wires are open. As shown in Figure 25, the 1-10 V wires function as a switch in the Dynadimmer override mode. Figure 26 depicts the voltage threshold necessary to activate the override functionality and the hysteresis margin.

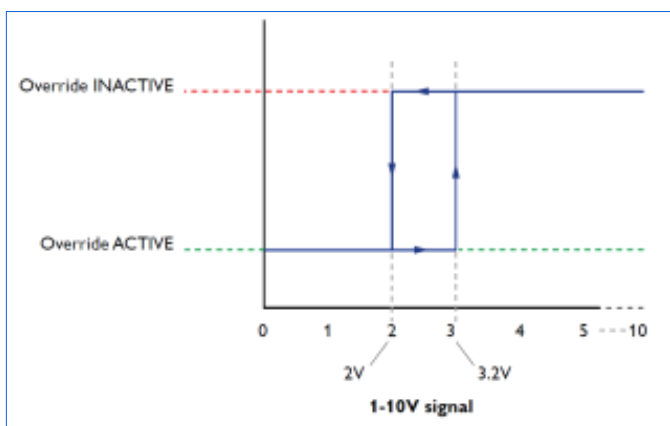

Figure 26 - Dynadimmer voltage threshold

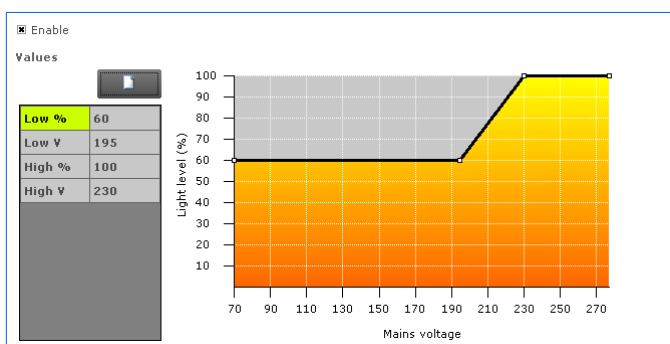

Figure 27 - Programming AmpDim functionality

Parameter	Min	Max	Increments
Start Voltage	170 V	250 V	1 V
Stop Voltage	150 V	230 V	1 V
Start Percent	30%	100%	1%
Stop Percent	30%	100%	1%
Start Voltage - Stop Voltage	20 V	100 V	

Figure 28 - AmpDim programming parameters

7.5. AmpDim

Historically mains dimming was used on magnetic ballasts to dim conventional lamps. By lowering the mains voltage, a proportionate reduction in light output was achieved. Until now electronic ballasts were not able to replicate this function. AmpDim enables cabinet based dimming without the need for additional control wires or infrastructure changes.

A cabinet controller signals to the driver to lower the light output via a reduction in the amplitude of the mains voltage. The intelligence embedded in the LED driver allows for a pre-programming of multiple dimming levels based on the amplitude of the mains voltage.

The default range of AmpDim is 170 V – 250 V. The range can be customized via the programming interface. It is possible to set the Start Voltage, Start Percent, Stop Voltage, and Stop Percent. Figure 27 shows an example of the AmpDim programming interface.

Programming note

- There needs to be a minimum of 20 V difference between Start and Stop Voltage settings when programming the driver.
- There must be a minimum delta of 5 V in the mains voltage before the driver starts dimming. This prevents accidental dimming due to small fluctuations in the mains voltage. Please refer to Figure 28 for complete parameters.

7.6. LineSwitch

The LineSwitch feature operates by using the extra mains pilot line. This is a one-step dimming solution which enables dimming of groups of light points to a predefined level with only a simple switch controlled by a timer, presence detector etc. Dimming to the desired level can be achieved by applying mains voltage to the LineSwitch driver input.

The pilot line wiring must be rated for the applied mains voltage. Copper diameter is not critical because this is a signal line with negligible current draw.

The driver mains input wiring is line- and neutral-polarized and its polarity should be observed.

The total pilot line cable length should not exceed 56m per driver based on a common parasitic cable capacitance of 100 pF/m.

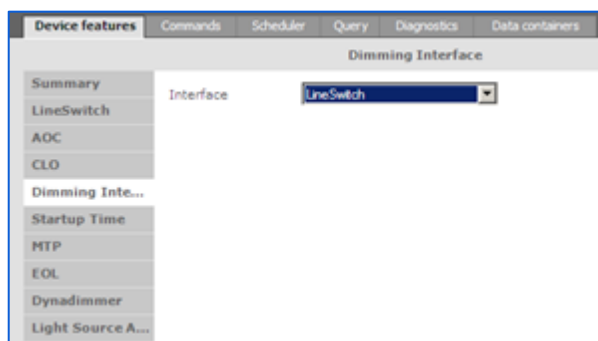

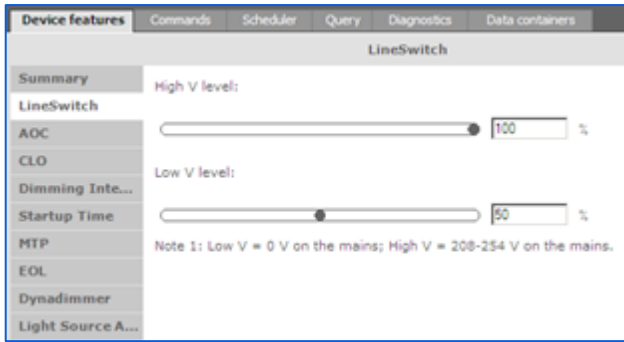

The change-over from full light level output to a predefined dimming level can be achieved by either disconnecting the pilot line mains from or applying mains voltage in the range of 220 ... 240V on the pilot line.

This feature can be enabled via the MultiOne Programming software in combination with the USB DALI programmer.

Configurable parameters are:

- Light Output in % when mains voltage (High V level) is present at the LineSwitch input:
- Light Output in % when no mains voltage is present (Low V level) at the LineSwitch input

8. Inrush current

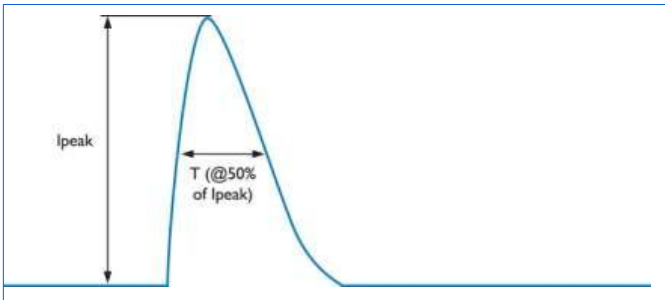

Figure 29 - Inrush current

‘Inrush current’ refers to the briefly occurring high input current which flows into the driver during the initial start-up to charge the capacitors on the input side. Typically, the amplitude is much greater than the operating or steady-state current, as illustrated in Figure 29.

The experimental setup for measuring the inrush current of the Xitanium LED Programmable driver is shown in Figure 30. For the test setup, a line impedance of $645\text{ m}\Omega / 22\text{ }\mu\text{H}$ (nom values) is used (NEMA 410 standard requires a line impedance comprised of $450\text{ m}\Omega / 100\text{ }\mu\text{H}$ for inrush current measurement). For the measurements, an input DC voltage equal to the peak of the corresponding line voltage is applied (via the capacitor bank).

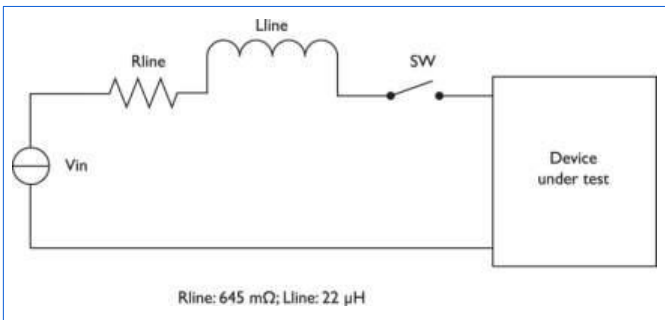

Figure 30 - Experimental set-up inrush current

On a system with an ABB S261 B16 miniature circuit breaker, up to a maximum certain number of Xitanium LED programmable drivers can be connected in parallel without the miniature circuit breaker tripping at driver turn-on. The exact maximum number can be found in the applicable driver datasheet. Please note that the inrush current does not increase proportionally with the number of drivers connected in parallel; i.e. for “N” drivers connected in parallel does not equal “N” times the inrush current for one driver.

9. Surge protection

The Xitanium programmable LED drivers have limited build-in surge protection. Depending on the geographical location, additional protection against excessive high surge voltages may be required by adding the Philips Surge Protection Device. More information about surge protection see www.philips.com/surgeprotection

10. Leakage current

The Xitanium LED programmable drivers are designed to meet leakage current requirements per IEC 61347-1 and UL 8750 standards. The specified maximum values are 0.7 mA peak for IEC and 0.75 mA RMS for UL norms. The test is done with the driver alone. In a luminaire, leakage current may be higher, since the LED load introduces additional leakage capacitance. As such, precautions should be taken on the luminaire level and if multiple drivers are used in the light engine.

11. Electromagnetic compatibility (EMC)

Xitanium LED programmable drivers meet EMC requirements per CISPR 15 ed 7.2 and FCC Title 47 Part 15 Class A. These tests are conducted with a reference setup that includes a driver and an LED load/heat sink combination mounted on a metal plate. To maintain good EMC performance at the luminaire level, the input, output and control wires should be kept as far apart as possible. Addition of ferrite beads in series with the wires, or coupling the wires through ferrite cores within the luminaire may improve the overall EMC performance. However, selection of the type and characteristics of the additional filter depends on what frequency components have to be damped and by how much.

12. Electrical isolation

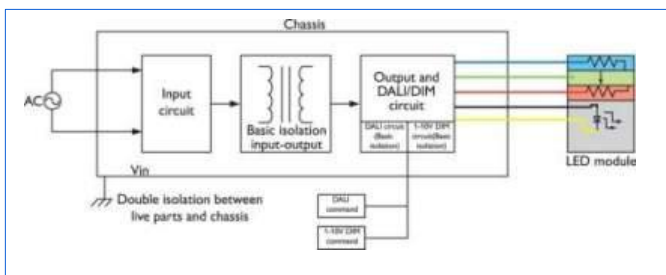

Figure 31 - Xitanium Programmable LED driver isolation

The Xitanium programmable LED drivers have basic isolation from the primary to the secondary side and double isolation between all the electronic circuits and the chassis. Figure 31 illustrates the isolation scheme.

The Xitanium programmable LED drivers meet the IEC 61347-1 safety standard. In accordance to this standard, the following safety requirements are met:

- Basic isolation between the Primary and Secondary side wires:
 - Driver output voltage < 1000 VDC
 - Insulation test voltage: $1000\text{ V} + 2 \times 305 (\approx 1750\text{ V})$
- Double isolation between all the wires and the chassis:
 - Insulation test voltage: 3750 V.

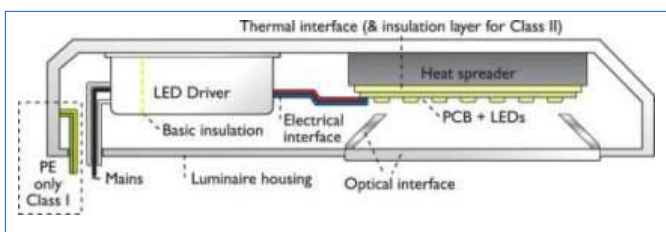

Figure 32 - Luminaire design example

All of the wires in the Xitanium programmable LED drivers meet the UL1452 safety standards.

13. DC emergency operation

The Xitanium Programmable 75W 0.7A Prog+ 230V-F sXt and 150W 0.7A Prog+ 230V-F sXt drivers are released for centralized DC emergency lighting applications with the exclusion of high-risk task areas. The drivers are suitable for operation on a DC grid with a DC voltage range as specified in the driver datasheet.

Attention point for DC grid operation:

- Use of an additional external DC voltage/current rated fuse is required.
- The internal driver fuse is not rated for DC operation.

These drivers are equipped with an auto-detect DC feature.

As soon as a DC input voltage is detected by these drivers, it will set the output current AOC to a predefined emergency dim level.

This dim level can be modified by using the MultiOne software.

The default emergency dim level is 15%.
The maximum level that can be set is 60%.

The minimum dim level at DC operation cannot be set lower than the minimum defined output current of the driver as specified in the driver datasheet.

Module temperature protection and driver temperature protection remain active during DC operation.

14. Programming

Xitanium programmable LED drivers are programmed via the Philips MultiOne Programming interface.

14.1. Programming time

Depending on the selected features to program, the programming time varies between 2-15 seconds. It is possible to program up to 64 drivers at the same time. However, there is no individual confirmation from each driver.



Figure 33 - Philips MultiOne programming interface

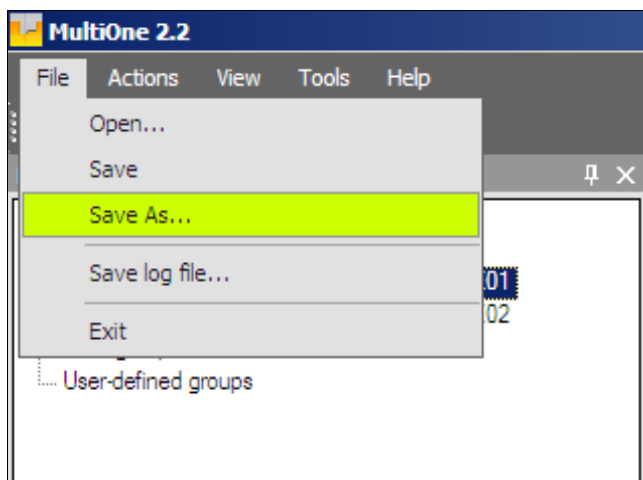

Figure 34 - Saving a driver profile

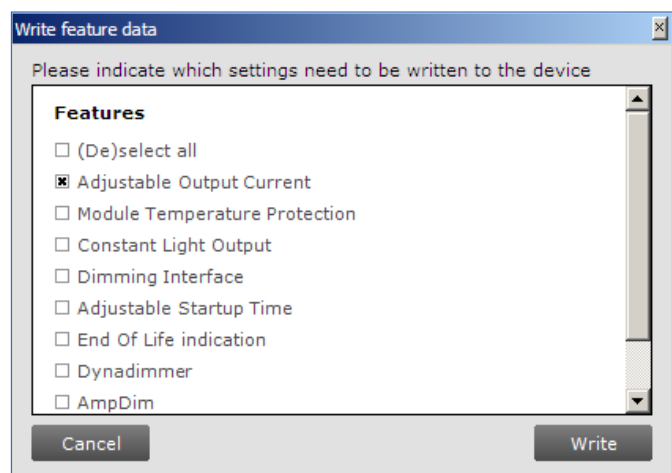

Figure 35 - Selective programming

14.2. Profiles

14.2.1. Saving a driver profile

Once settings for a driver have been defined using the MultiOne interface, these settings can be saved for future use. By following *File* → *Save As* (Figure 34). The file is saved in XML format. The profile is stored only in the .XML file and not in the driver. (Figure 34).

14.2.2. Loading a profile

A previously saved profile can be loaded by using the *File*→*Open* option.

14.2.3. Selective programming

In the MultiOne interface, it is possible to select only a specific feature to be programmed. For example, if the user would like to only change the module current, then only the AOC feature can be selected while other features can be left blank(Figure 35).

14.2.4. Version management

The driver software version is stated in the software name, e.g. MultiOne 2.2. Please visit www.philips.com/multione to install the latest version of the programming software.

For more information on the programming interface, please visit www.philips.com/multione. This site contains detailed information on how to install the software and how to program the driver.

15. Integrated Dynadimmer settings

15.1. Synchronising changes to ON-Time duration

There are two possibilities when there is a change in ON-time duration between successive dimming cycles. Following are two examples.

15.2. Settings change: More than 1 hr difference

When the change in ON-time is greater than 1 hour: Similar to the learning mode explained in Figure 6, the driver will need 3 cycles to learn the new ON-time duration and synchronize with Dynadimmer schedule setting. Figure 36 shows this scenario, where the ON-time cycle changes from 8 hours to 5 hours ($8-5= 3 > 1$ hour).



Figure 36 - Change in ON-time duration > 1 hour

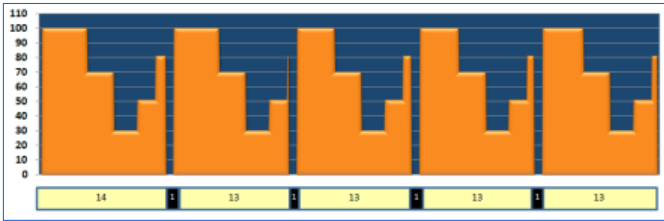

Figure 37 - Dimming scene setting when ON-time changes from 14 hours to 13 hours

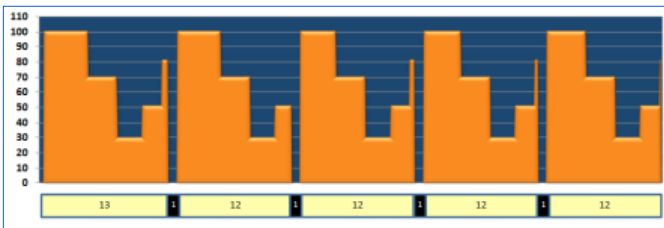

Figure 38 - Dimming scene setting when ON-time changes from 13 hours to 12 hours

15.3. Settings change: Less than 1 hr difference

When the change in ON-time duration is less than or equal to 1 hour: This represents normal operation, wherein the driver averages the last 3 ON-times and calculates the virtual clock time. The dimming schedule stays active while gradually adapting to the new ON-time. Figure 37 and 38 show the sequence of events as the ON-time changes from 14 to 13, and finally 12 hours.

15.4. Input mains power interruption

If the input mains voltage drops to zero for more than 1 second, the driver will record it as a turn OFF event and will try to re-calculate the virtual clock time again when mains power is restored. This only means that the driver will need to synchronize to regular ON-time duration. (See previous section - *Synchronization to change in ON-time duration*).

On the other hand, if the duration of a mains voltage drop to 0V is less than 1 second, energy to sustain the microcontroller operation within the driver is not lost and hence the Dynadim dimming cycle remains unaffected.

15.5. Input mains power dip

The driver is robust enough to handle an input mains voltage dip to 25 V for 1 minute. Light output will reduce for the duration of the mains dip, but the dimming cycle will not be affected.

15.6. Input Mains Power OFF for maintenance or temporary power outage

This scenario is illustrated in Figure 39. The driver will go to full 100% light output for the subsequent cycle after a power outage and then continue with regular dimming schedule.

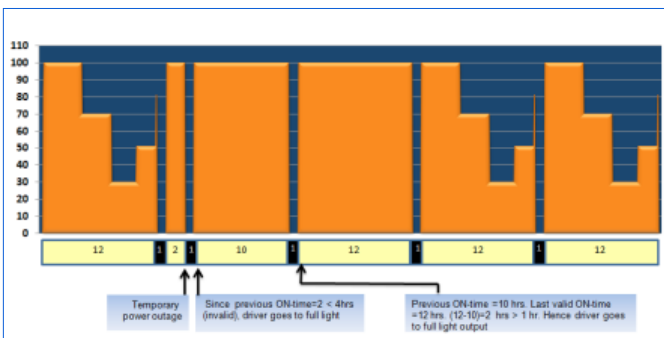

Figure 39 - Temporary power outage or mains power interruption for maintenance

15.7. Programming a new dimming schedule

A new dimming schedule can be programmed any time the driver is powered ON. The new dimming schedule takes effect immediately after programming (Figure 40).

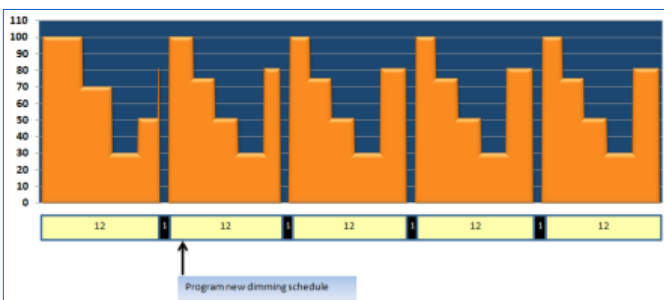

Figure 40 - Programming new Dynadimmer schedule

For more information please visit:

www.philips.com/outdoor

© 3/29/2014 Koninklijke Philips Electronics N.V.

All rights reserved. Reproduction in whole or in part is prohibited without the prior written consent of the copyright owner. The information presented in this document does not form part of any quotation or contract, is believed to be accurate and reliable and may be changed without notice. No liability will be accepted by the publisher for any consequence of its use. Publication thereof does not convey nor imply any license under patent or other industrial or intellectual property rights.