

**PHILIPS**

Fortimo

LED system

DLM Flex 1100 lm Gen2



## Datasheet

# A new generation solution for downlight applications

### Fortimo LED DLM Flex 1100 lm Gen2

The Fortimo LED DLM Flex G2 is a new generation solution for down light applications. It is a product in line with the Fortimo brand promise of light quality and a smart system. We provide you with a system proposition ranging from 1100 lm to 5000 lm, with the flexibility to tune as per your needs.

#### Benefits

- Increased energy efficiency
- Flexibility to tune the performance as per your need by modifying the operating point
- Improved luminaire manufacturability
- Improved temperature management
- Smart systems with Xitanium drivers, including the new mini drivers
- Part of the Philips warranty scheme
- Best in class lumen maintenance

#### Features

- Ability to operate your module at a desired current
- Flexibility to choose between the PCB, with or without the housing
- Two choices for the housing, a high housing having the same form factor as the DLM G5 and the shallow housing, having the same foot print as the DLM G5, but slimmer
- One stop shop for your system (detailed list of complementary partners in design-in guide)

## Ordering Data

Commercial product name	Type	EOC	12NC
Fortimo LED DLM Flex 1100/830 Gen2	LED board	6947939 121144 00	92900 1503 880
Fortimo LED DLM Flex 1100/840 Gen2	LED board	6947939 121168 00	92900 1503 980
Fortimo LED DLM Flex Cover	Shallow housing	8718291 797456 00	92900 0908 506
Fortimo LED DLM Flex High Cover	High housing	8718696 421178 00	92900 0927 806
Fortimo LED DLM Flex cable 600mm	Cable	8718696 421192 00	92900 0910 706

## Drive Currents and Case Temperature

Parameter	Nominal*	Life**	Max***	Unit
I (LED board only) - 830	227	227	480	mA
I (LED board + shallow housing) - 830	277	277	480	mA
I (LED board + high housing) - 830	388	388	480	mA
I (LED board only) - 840	208	208	480	mA
I (LED board + shallow housing) - 840	252	252	480	mA
I (LED board + high housing) - 840	305	305	480	mA
Tc (Case temperature at Tc point)	75	75	85	°C

\* Nominal value at which typical performance is specified.

\*\* Value at which lifetime is specified.

\*\*\* Maximum value for safe operation, do not operate above this value.

## Electrical Characteristics

Parameter	Typ	Max	Unit
Forward Voltage (LED board only) - 830	34.1	36.9	V
Forward Voltage (LED board + shallow housing) - 830	34.5	37.2	V
Forward Voltage (LED board + high housing) - 830	34.9	37.2	V
Forward Voltage (LED board only) - 840	34	36.7	V
Forward Voltage (LED board + shallow housing) - 840	34.3	37	V
Forward Voltage (LED board + high housing) - 840	34.6	37	V
Power Consumption (LED board only) - 830	7.7	17.7	W
Power Consumption (LED board + shallow housing) - 830	9.5	17.9	W
Power Consumption (LED board + high housing) - 830	11.8	17.9	W
Power Consumption (LED board only) - 840	7.1	17.6	W
Power Consumption (LED board + shallow housing) - 840	8.6	17.8	W
Power Consumption (LED board + high housing) - 840	10.5	17.8	W

Specifications stated at Tc-nom and I-nom.

## Absolute Maximum Ratings

Parameter	Min	Typ	Max	Unit
Current through the LED module (I-max)			480	mA
Case temperature (Tc-max)			85	°C
Human Body Model (HBM) Class 2A JS-001-2012			4	kV
Storage temperature	-40		100	°C

## Optical characteristics - table per CCT

### Fortimo LED DLM Flex 1100 lm 830 Gen2

Parameter	Min	Typ	Unit
Luminous Flux		1100	lm
Efficacy: LED board		142	lm/W
Efficacy: LED board + shallow housing		115	lm/W
Efficacy: LED board + high housing		93	lm/W
Correlated color temperature (CCT) range		3000	K
CRI	80		-
Energy efficiency label Fortimo LED DLM Flex 1100/830 Gen2		A++	
Energy efficiency label Fortimo LED DLM Flex 1100/830 Gen2 + Shallow Housing		A+	
Energy efficiency label Fortimo LED DLM Flex 1100/830 Gen2 + High Housing		A+	

Color consistency of 3 SDCM, averaged over the module.

Operation Point	830	lm	lm/W
80% I-nom	Tc 65 °C	920	122
	Tc- nom 75 °C	900	120
	Tc - max 85 °C	880	118
I-nom	Tc 65 °C	1130	117
	Tc- nom 75 °C	1100	115
	Tc - max 85 °C	1080	113
I-max	Tc 65 °C	1780	101
	Tc- nom 75 °C	1740	99
	Tc - max 85 °C	1700	97

Tolerance for flux data is -10% - +20%.

Tolerance for Vf data is ±10%.

Tolerance for efficacy data is dependent on the above mentioned tolerances.

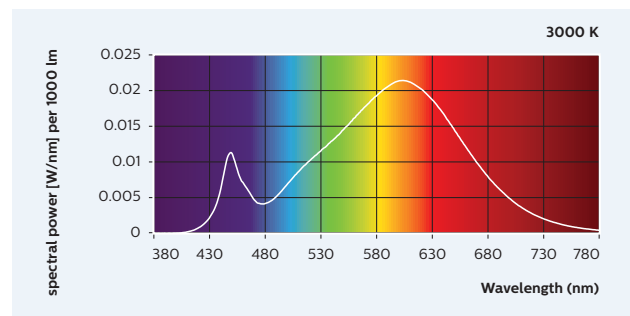

### Fortimo LED DLM Flex 1100 lm 840 Gen2

Parameter	Min	Typ	Unit
Luminous Flux		1100	lm
Efficacy: LED board		155	lm/W
Efficacy: LED board + shallow housing		127	lm/W
Efficacy: LED board + high housing		104	lm/W
Correlated color temperature (CCT) range		4000	K
CRI	80		-
Energy efficiency label Fortimo LED DLM Flex 1100/840 Gen2		A++	
Energy efficiency label Fortimo LED DLM Flex 1100/840 Gen2 + Shallow Housing		A++	
Energy efficiency label Fortimo LED DLM Flex 1100/840 Gen2 + High Housing		A+	

Color consistency of 3 SDCM, averaged over the module.

Operation Point	840	lm	lm/W
80% I-nom	Tc 65 °C	920	133
	Tc- nom 75 °C	900	131
	Tc - max 85 °C	880	129
I-nom	Tc 65 °C	1130	128
	Tc- nom 75 °C	1100	126
	Tc - max 85 °C	1080	124
I-max	Tc 65 °C	1940	108
	Tc- nom 75 °C	1890	107
	Tc - max 85 °C	1840	105

Tolerance for flux data is -10% - +20%.

Tolerance for Vf data is ±10%.

Tolerance for efficacy data is dependent on the above mentioned tolerances.

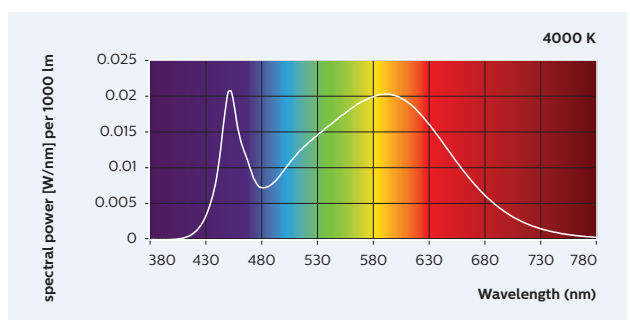

## Beam shape

The Philips Fortimo LED DLM Flex generates a Lambertian beam shape, which is a pragmatic starting point for OEMs wishing to design secondary optics.

Polar intensity diagram

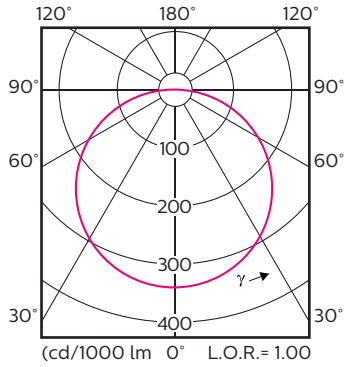

Only LED board (L2)

Polar intensity diagram

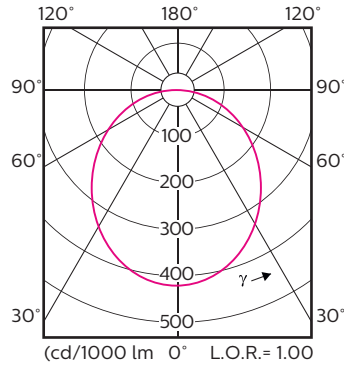

With Shallow Housing (L2+)

Polar intensity diagram

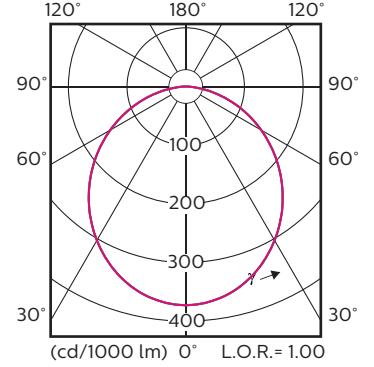

With High Housing (L2+)

## Lifetime

Operation Point	Lifetime x 1000 hours	L70			L80			L90		
		B50	B20	B10	B50	B20	B10	B50	B20	B10
80% of Inom	Tc 55 °C	> 60	> 60	> 60	47	46	45	22	21	21
	Tc 65 °C	> 60	> 60	> 60	42	41	40	20	19	19
	Tc 75 °C	> 60	> 60	59	38	37	37	18	17	17
	Tc 85 °C	56	54	54	35	34	33	16	16	15
Inom	Tc 55 °C	> 60	> 60	> 60	45	44	43	21	20	20
	Tc 65 °C	> 60	> 60	> 60	41	40	39	19	18	18
	Tc 75 °C	> 60	58	57	37	36	35	17	17	16
	Tc 85 °C	54	53	52	34	33	32	16	15	15
Imax	Tc 55 °C	> 60	> 60	> 60	43	41	41	20	19	19
	Tc 65 °C	> 60	> 60	59	38	37	37	18	17	17
	Tc 75 °C	56	54	54	35	34	33	16	16	15
	Tc 85 °C	51	50	49	32	31	30	15	14	14

## Mechanical characteristics

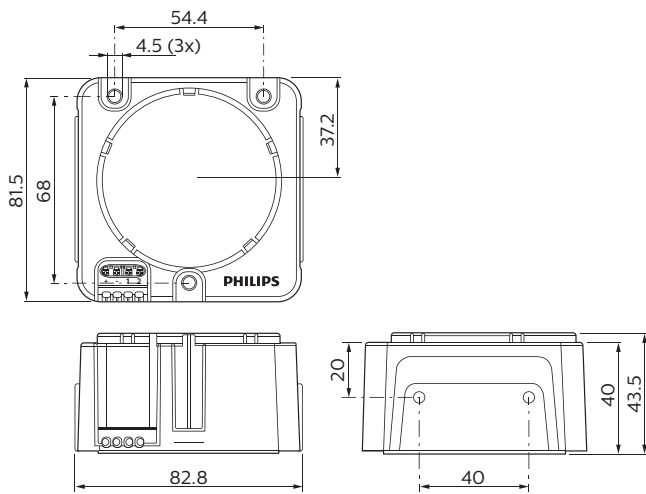

High housing

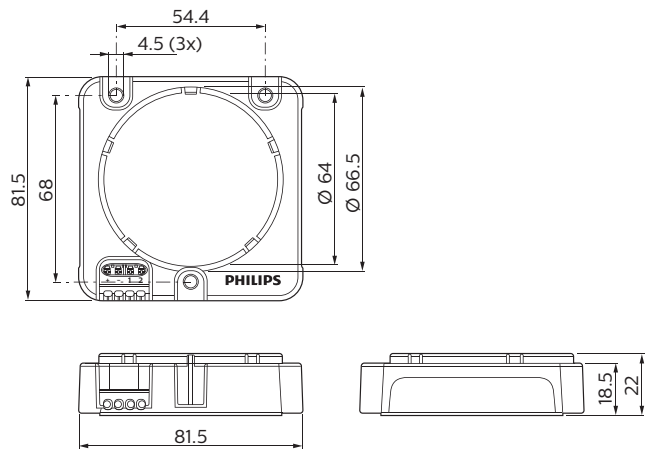

Shallow housing

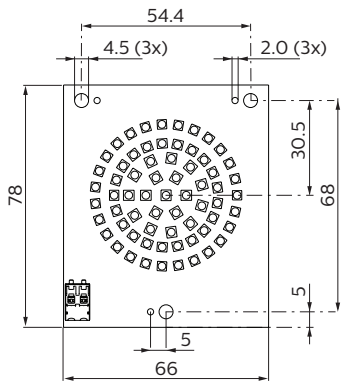

LED board

Dimensions in mm

## Application information

### Compliance and approval

IEC/EN 62031, IEC 62471

#### Application information

IP rating	No IP rating
Overheating protection	No protection

## Tuning information

### Flux and Efficacy vs Current (At $T_c = 75\text{ }^\circ\text{C}$ , for LED board + housing)

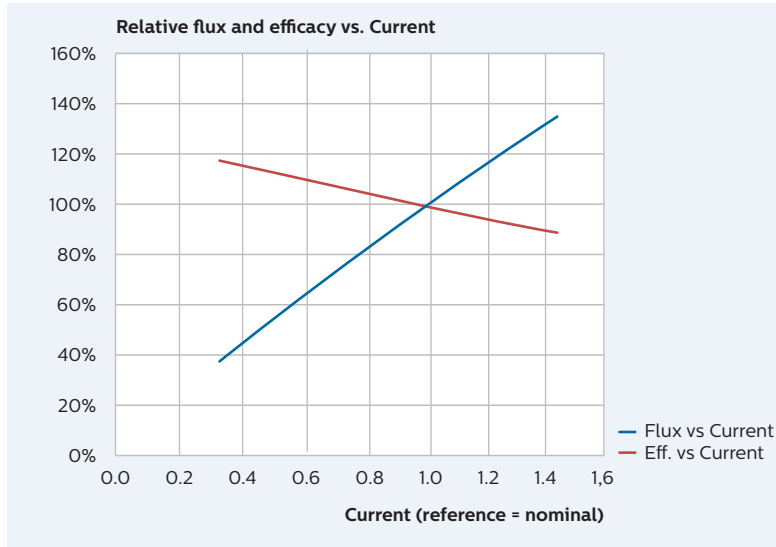

### Flux and Efficacy vs Temperature (At $I = I_{nom}$ , for LED board + housing)

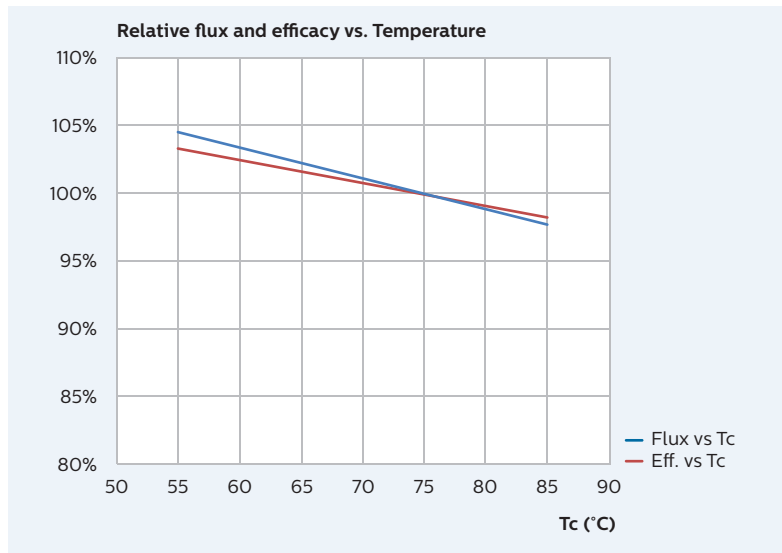

## Lumen maintenance

### Lumen maintenance at I-life and Tc-life conditions Fortimo LED DLM Flex 1100 lm Gen2

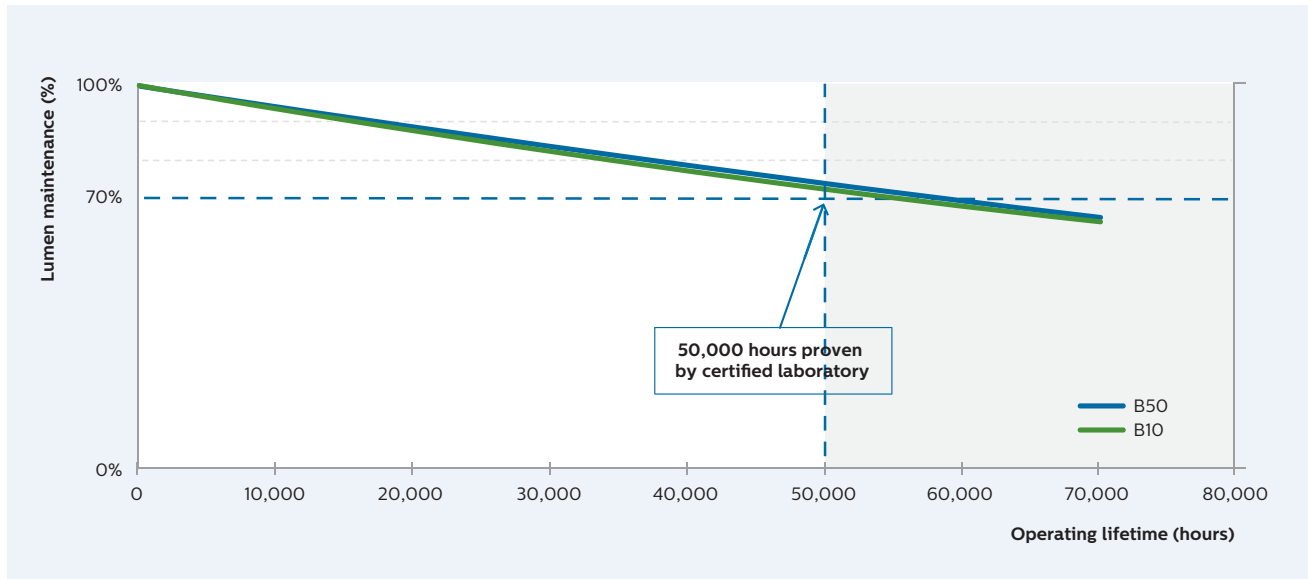

### Lumen maintenance for B50 at current I-life conditions Fortimo LED DLM Flex 1100 lm Gen2

