

PHILIPS ADVANCE

High Pressure Sodium Lamp Ballast

Catalog Number 71A8351A
For 310W S-67
60 Hz CWA
Status: Active

DIMENSIONS AND DATA

4 1/4 X 4 3/4 CORE - 2 COIL UNIT

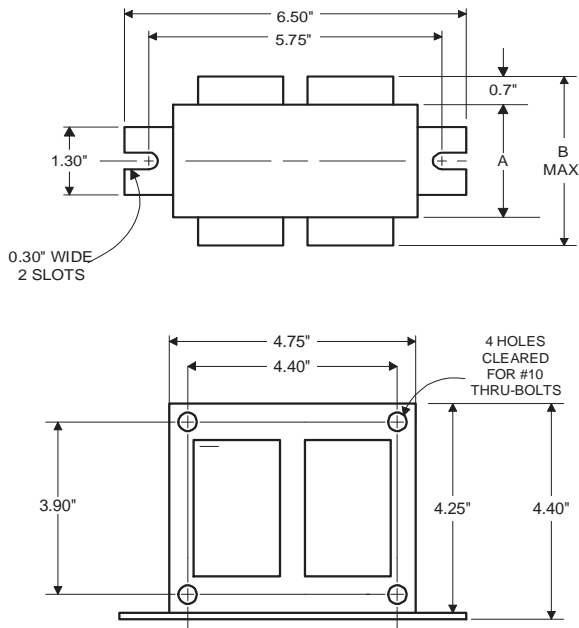

	120	208	240	277	480
INPUT VOLTS					
CIRCUIT TYPE	CWA				
POWER FACTOR (min)	90%				
REGULATION	±10%				
Line Volts	WITHIN TRAPEZOID				
Lamp Watts					
LINE CURRENT (Amps)					
Operating.....	3.12	1.70	1.55	1.33	0.77
Open Circuit.....	1.43	0.70	0.72	0.60	0.35
Starting.....	2.50	1.40	1.24	1.05	0.59
UL TEMPERATURE RATINGS					
Insulation Class	H(180°C)				
Coil Temperature Code	1029				
MIN. AMBIENT STARTING TEMP.	-40°F or -40°C				
NOM. OPEN CIRCUIT VOLTAGE	183				
INPUT VOLTAGE AT LAMP DROPOUT.....	81	148	162	185	318
INPUT WATTS	367				
RECOMMENDED FUSE (Amps).....	8	5	4	4	2
CORE and COIL					
Dimension (A)	2.42				
Dimension (B)	4.10				
Weight (lbs.)	14				
Lead Lengths	12"				
CAPACITOR REQUIREMENT					
Microfarads	45.0				
Volts (min.)	280				
Fault Current Withstand (amps)					
60 Hz TEST PROCEDURES (Refer to Advance Test Procedure for HID Ballasts - Form 1270)					
High Potential Test (Volts)					
1 minute	2000				
2 seconds	2500				
Open Circuit Voltage Test (Volts)	165-201				
Short-Circuit Current Test (Amps)					
Secondary Current	4.72-5.77				
Input Current.....	1.75-2.62	1.00-1.50	0.87-1.30	0.75-1.12	0.43-0.64

Capacitor: 7C450P30RA

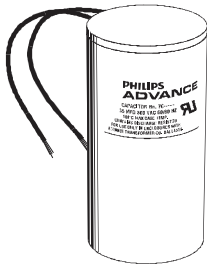

Capacitance: 45
Dia/Oval Dim: 1.85
Height: 4.7
Temp Rating: 105°C

Wiring Diagram:

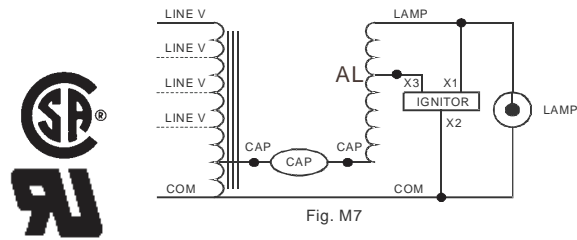

Ordering Information

Order Suffix

Description

Ignitor: LI501-H4

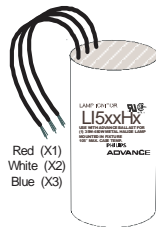

Red (X1)
White (X2)
Blue (X3)

Ballast to Lamp Distance
(BTL) = 2 feet
Temp Rating: 105°C

Data is based upon tests performed by Philips Lighting Electronic N.A. in a controlled environment and representative of relative performance. Actual performance can vary depending on operating conditions. Specifications are subject to change without notice.

Philips Lighting Electronic N.A.

10275 West Higgins Road · Rosemont, IL 60018 · Tel:800-322-2086 Fax:888-432-1882
Customer Support/ Technical Service:800-372-3331 · OEM Support: 866-915-5886

08/13/13