

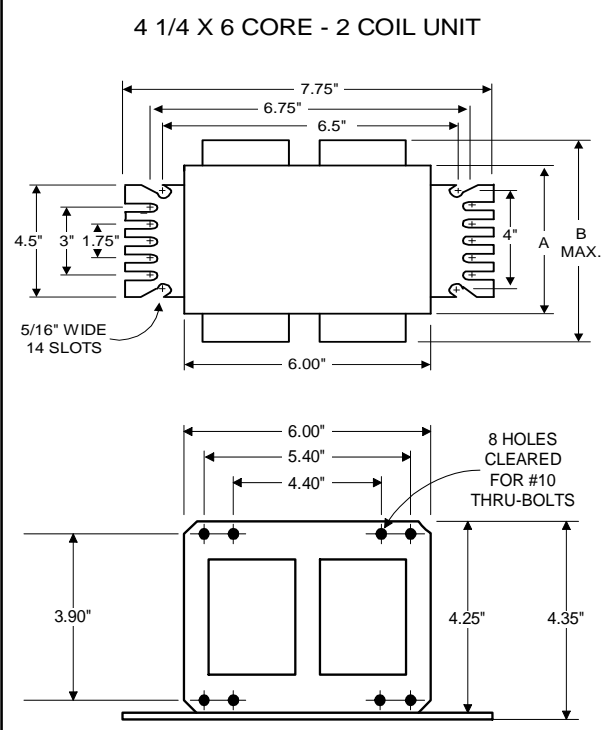

High Pressure
Sodium
Lamp Ballast

Catalog Number 71A87A3
For 1000W S52
60 Hz CWA
Status: Active

DIMENSIONS AND DATA



INPUT VOLTS	120	277	347		
CIRCUIT TYPE	CWA				
POWER FACTOR (min)	90%				
REGULATION	±10%				
Line Volts	WITHIN TRAPEZOID				
Lamp Watts					
LINE CURRENT (Amps)					
Operating.....	9.50	4.20	3.30		
Open Circuit.....	3.70	1.40	1.10		
Starting.....	6.40	2.80	2.20		
UL TEMPERATURE RATINGS					
Insulation Class	H(180°C)				
Coil Temperature Code	1029				
MIN. AMBIENT STARTING TEMP.	-40°F or -40°C				
NOM. OPEN CIRCUIT VOLTAGE	435				
INPUT VOLTAGE AT LAMP DROPOUT.....	90	156	260		
INPUT WATTS	1100				
RECOMMENDED FUSE (Amps).....	25	15	10		
CORE and COIL					
Dimension (A)	3.90				
Dimension (B)	5.90				
Weight (lbs.)	28				
Lead Lengths	12"				
CAPACITOR REQUIREMENT					
Microfarads	26.0				
Volts (min.)	525				
Fault Current Withstand (amps)					
60 Hz TEST PROCEDURES (Refer to Advance Test Procedure for HID Ballasts - Form 1270)					
High Potential Test (Volts)					
1 minute	2000				
2 seconds	2500				
Open Circuit Voltage Test (Volts)	395-485				
Short-Circuit Current Test (Amps)					
Secondary Current	6.40-7.80				
Input Current.....	6.90-10.4	3.00-4.60	2.50-3.70	-	-

Capacitor: RW1626020 MD2602-100

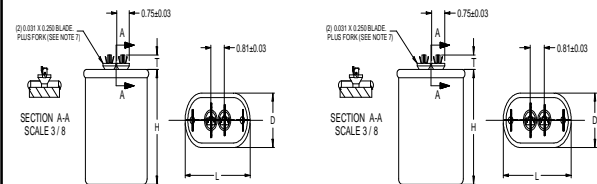

Capacitance:	26	Capacitance:	26
Dia/Oval Dim:	1.75	Dia/Oval Dim:	1.75
Height:	4.25	Height:	5.3
Temp Rating:	90°C	Temp Rating:	90°C

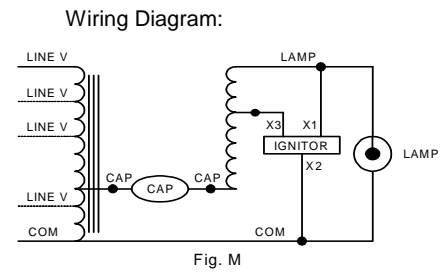

Ordering Information

Order Suffix	Description
500.	Ballast with Ignitor and Oil Filled Capacitor

Ignitor: LI571-H5

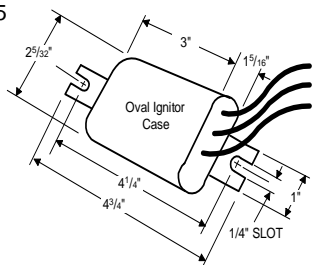

Ballast to Lamp Distance (BTL) = 15 feet
Temp Rating: 105°C

Data is based upon tests performed by Advance Transformer in a controlled environment and representative of relative performance. Actual performance can vary depending on operating conditions. Specifications are subject to change without notice.

ADVANCE TRANSFORMER CO.

O'HARE INTERNATIONAL CENTER · 10275 WEST HIGGINS ROAD · ROSEMONT, IL 60018
Customer Support/Technical Service: Phone: 800-372-3331 · Fax: 847-768-7768
Corporate Offices: Phone: 800-322-2086

06/07/11