

# PHILIPS ADVANCE

Metal  
Halide  
Lamp Ballast

Catalog Number 71A5570  
For 175/150W M57/M107  
60 Hz CWA  
Status: Active

### DIMENSIONS AND DATA

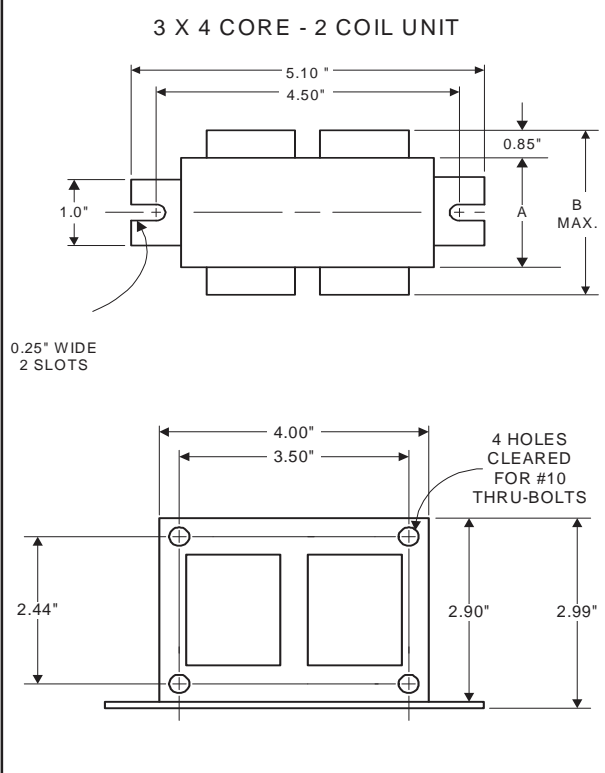

Capacitor: 7C100M40-R

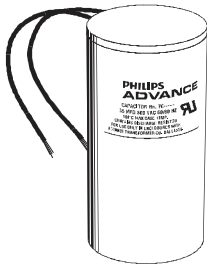

Capacitance: 10  
Dia/Oval Dim: 1.45  
Height: 3.75  
Temp Rating: 105°C

Ignitor: NA

This ballast does not require the use of an ignitor.

	120	208	240	277
INPUT VOLTS				
CIRCUIT TYPE	CWA			
POWER FACTOR (min)	90%			
REGULATION				
Line Volts	±10%			
Lamp Watts	±10%			
LINE CURRENT (Amps)				
Operating.....	1.80	1.04	0.90	0.80
Open Circuit.....	1.78	1.08	0.93	0.81
Starting.....	1.26	0.70	0.61	0.53
UL TEMPERATURE RATINGS				
Insulation Class	H(180°C)			
Coil Temperature Code	1029			
MIN. AMBIENT STARTING TEMP.	-20°F or -30°C			
NOM. OPEN CIRCUIT VOLTAGE	305			
INPUT VOLTAGE AT LAMP DROPOUT.....	60	104	120	138
INPUT WATTS	210			
RECOMMENDED FUSE (Amps).....	5	3	3	2
CORE and COIL				
Dimension (A)	2.42			
Dimension (B)	3.95			
Weight (lbs.)	7.5			
Lead Lengths	12"			
CAPACITOR REQUIREMENT				
Microfarads	10.0			
Volts (min.)	400			
Fault Current Withstand (amps)				
60 Hz TEST PROCEDURES (Refer to Advance Test Procedure for HID Ballasts - Form 1270)				
High Potential Test (Volts)				
1 minute	2000			
2 seconds	2500			
Open Circuit Voltage Test (Volts)	275-335			
Short-Circuit Current Test (Amps)				
Secondary Current	1.50-1.90			
Input Current.....	1.06-1.59	0.60-0.90	0.52-0.78	0.45-0.67

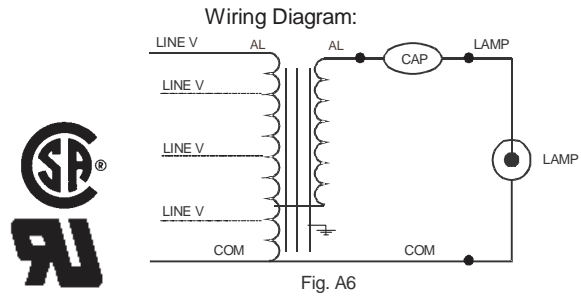

### Ordering Information

Order Suffix	Description

Data is based upon tests performed by Philips Lighting Electronic N.A. in a controlled environment and representative of relative performance. Actual performance can vary depending on operating conditions. Specifications are subject to change without notice.