

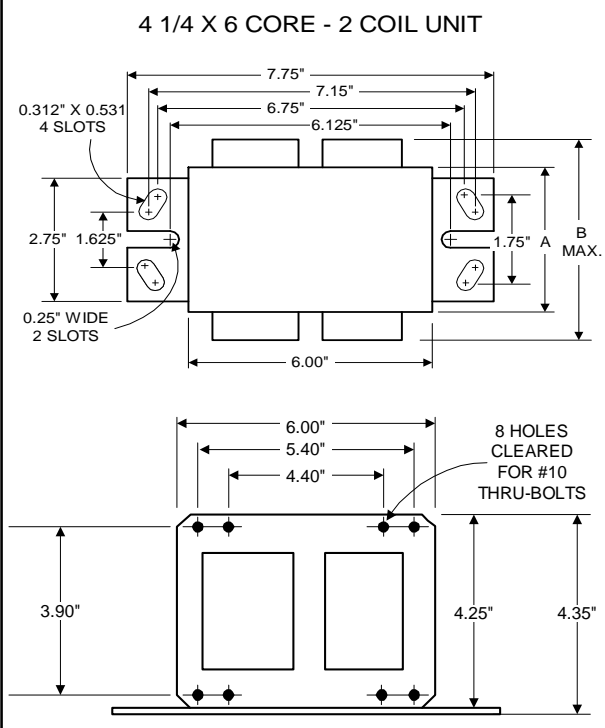

Metal
Halide
Lamp Ballast

Catalog Number 71A65F3TA
For 1000W M141 (Pulse Start)
60 Hz CWA
Status: Active

DIMENSIONS AND DATA



	277	347	480		
INPUT VOLTS					
CIRCUIT TYPE	CWA				
POWER FACTOR (min)	90%				
REGULATION					
Line Volts	±10%				
Lamp Watts	±10%				
LINE CURRENT (Amps)					
Operating.....	3.96	3.17	2.26		
Open Circuit.....	1.91	1.52	1.05		
Starting.....	3.13	2.46	1.81		
UL TEMPERATURE RATINGS					
Insulation Class	N(200°C)				
Coil Temperature Code	1029				
	D	D	D		
MIN. AMBIENT STARTING TEMP.	-20°F or -30°C				
NOM. OPEN CIRCUIT VOLTAGE	433				
INPUT VOLTAGE AT LAMP DROPOUT.....	190	240	320		
INPUT WATTS	1080				
RECOMMENDED FUSE (Amps).....	10	8	6		
CORE and COIL					
Dimension (A)	3.30				
Dimension (B)	5.30				
Weight (lbs.)	21				
Lead Lengths	12"				
CAPACITOR REQUIREMENT					
Microfarads	24.0				
Volts (min.)	480				
Fault Current Withstand (amps)					
60 Hz TEST PROCEDURES (Refer to Advance Test Procedure for HID Ballasts - Form 1270)					
High Potential Test (Volts)					
1 minute	2000				
2 seconds	2500				
Open Circuit Voltage Test (Volts)	3900-476				
Short-Circuit Current Test (Amps)					
Secondary Current	4.60-6.90				
Input Current.....	2.50-3.76	1.97-2.95	1.45-2.17	-	-

Capacitor: MD2409-000

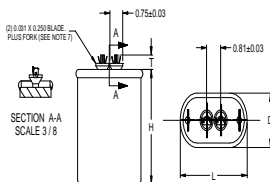

Capacitance: 24
Dia/Oval Dim: 1.75
Height: 3.9
Temp Rating: 90°C

Wiring Diagram:

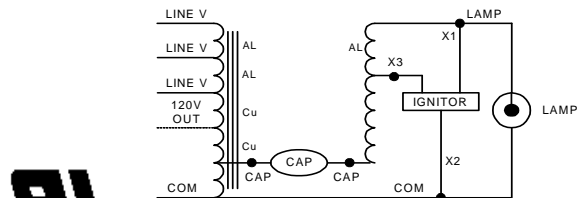
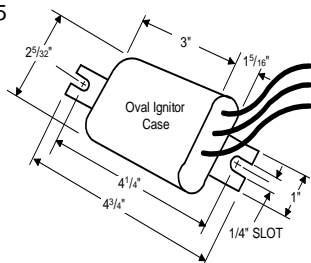

Fig. MT3

Ignitor: LI571-H5



Ballast to Lamp Distance (BTL) = 5 feet
Temp Rating: 105°C

Ordering Information

Order Suffix	Description
500.	Ballast with Ignitor and Oil Filled Capacitor

Data is based upon tests performed by Advance Transformer in a controlled environment and representative of relative performance. Actual performance can vary depending on operating conditions. Specifications are subject to change without notice.

ADVANCE TRANSFORMER CO.

O'HARE INTERNATIONAL CENTER · 10275 WEST HIGGINS ROAD · ROSEMONT, IL 60018
Customer Support/Technical Service: Phone: 800-372-3331 · Fax: 847-768-7768
Corporate Offices: Phone: 800-322-2086

07/08/11