

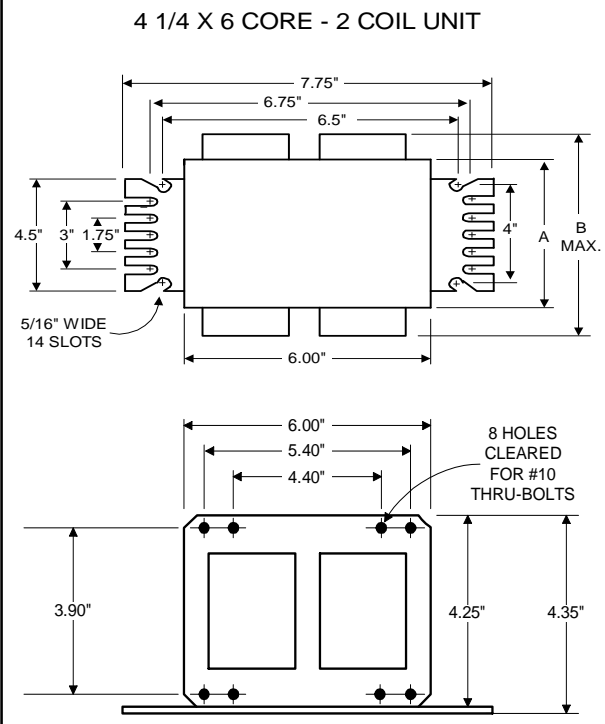

Metal
Halide
Lamp Ballast

Catalog Number 71A6742
For 1500W M48
60 Hz CWA
Status: Active

DIMENSIONS AND DATA



INPUT VOLTS	480				
CIRCUIT TYPE	CWA				
POWER FACTOR (min)	90%				
REGULATION					
Line Volts	±10%				
Lamp Watts	±12%				
LINE CURRENT (Amps)					
Operating.....	3.40				
Open Circuit.....	1.40				
Starting.....	3.30				
UL TEMPERATURE RATINGS					
Insulation Class	H(180°C)				
Coil Temperature Code	1029				
MIN. AMBIENT STARTING TEMP.	-20°F or -30°C				
NOM. OPEN CIRCUIT VOLTAGE	450				
INPUT VOLTAGE AT LAMP DROPOUT.....	320				
INPUT WATTS	1625				
RECOMMENDED FUSE (Amps).....	10				
CORE and COIL					
Dimension (A)	4.20				
Dimension (B)	6.20				
Weight (lbs.)	31				
Lead Lengths	12"				
CAPACITOR REQUIREMENT					
Microfarads	32.0				
Volts (min.)	525				
Fault Current Withstand (amps)					
60 Hz TEST PROCEDURES (Refer to Advance Test Procedure for HID Ballasts - Form 1270)					
High Potential Test (Volts)					
1 minute	2000				
2 seconds	2500				
Open Circuit Voltage Test (Volts)	405-495				
Short-Circuit Current Test (Amps)					
Secondary Current	7.40-9.00				
Input Current.....	2.40-3.70				

Capacitor: MD3202-100

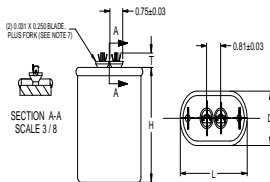

Capacitance: 32
Dia/Oval Dim: 2.00
Height: 3.75
Temp Rating: 90°C

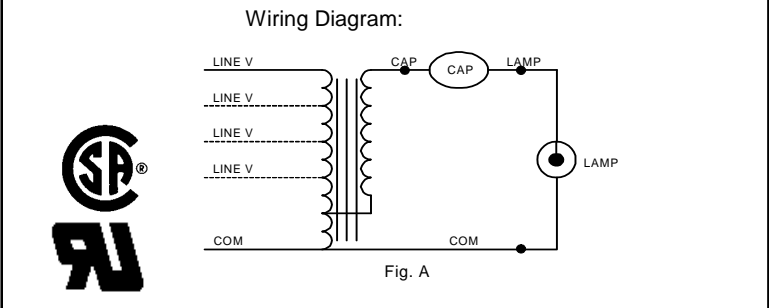

Ordering Information

Order Suffix	Description

Ignitor: NA

This ballast does not require the use of an ignitor.

Data is based upon tests performed by Advance Transformer in a controlled environment and representative of relative performance. Actual performance can vary depending on operating conditions. Specifications are subject to change without notice.