

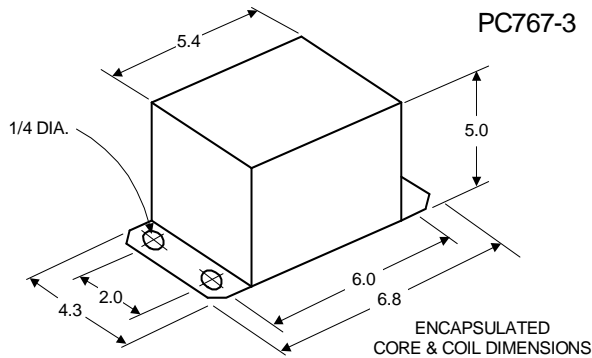

Metal  
Halide  
Lamp Ballast

Catalog Number 73B5892AEE  
For 320W M132/M154 (P.S.)  
60 Hz SUPER-CWA  
Status: Active

**DIMENSIONS AND DATA**



INPUT VOLTS	120	208	240	277
CIRCUIT TYPE	SUPER-CWA			
POWER FACTOR (min)	90%			
REGULATION				
Line Volts	±10%			
Lamp Watts	±10%			
LINE CURRENT (Amps)				
Operating.....	3.25	1.90	1.65	1.40
Open Circuit.....	2.30	1.25	1.17	1.00
Starting.....	2.07	1.25	1.02	0.90
UL TEMPERATURE RATINGS				
Insulation Class	H(180°C)			
Coil Temperature Code	1029			
	B	B	B	B
MIN. AMBIENT STARTING TEMP.	-20°F or -30°C			
NOM. OPEN CIRCUIT VOLTAGE	270			
INPUT VOLTAGE AT LAMP DROPOUT.....	60	104	120	138
INPUT WATTS	363			
RECOMMENDED FUSE (Amps).....	8	6	5	3
CORE and COIL				
Dimension (A)				
Dimension (B)				
Weight (lbs.)	19			
Lead Lengths	12"			
CAPACITOR REQUIREMENT				
Microfarads	21.0			
Volts (min.)	345			
Fault Current Withstand (amps)				
60 Hz TEST PROCEDURES (Refer to Advance Test Procedure for HID Ballasts - Form 1270)				
High Potential Test (Volts)				
1 minute	2000			
2 seconds	2500			
Open Circuit Voltage Test (Volts)	250-300			
Short-Circuit Current Test (Amps)				
Secondary Current	2.90-3.60			
Input Current.....	1.65-2.50	1.00-1.50	0.80-1.25	0.70-1.10

Capacitor: 7C210P40R



Capacitance: 21  
Dia/Oval Dim: 1.75  
Height: 4.8  
Temp Rating: 105°C



Wiring Diagram:

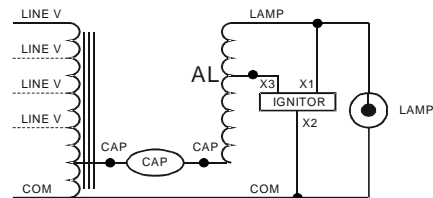

Fig. M7

Ordering Information

Order Suffix	Description

Ignitor: LI533-H4



Red (X1)  
White (X2)  
Blue (X3)

Ballast to Lamp Distance (BTL) = 2 feet  
Temp Rating: 105°C

Data is based upon tests performed by Advance Transformer in a controlled environment and representative of relative performance. Actual performance can vary depending on operating conditions. Specifications are subject to change without notice.

**ADVANCE TRANSFORMER CO.**

O'HARE INTERNATIONAL CENTER · 10275 WEST HIGGINS ROAD · ROSEMONT, IL 60018  
Customer Support/Technical Service: Phone: 800-372-3331 · Fax: 847-768-7768  
Corporate Offices: Phone: 800-322-2086

08/07/12