



Metal  
Halide  
Lamp Ballast

Catalog Number 79W6592  
For 1000W M47  
60 Hz CWA  
Status: Active

**DIMENSIONS AND DATA**

79W  
OUTDOOR  
WEATHERPROOF  
DIMENSIONS

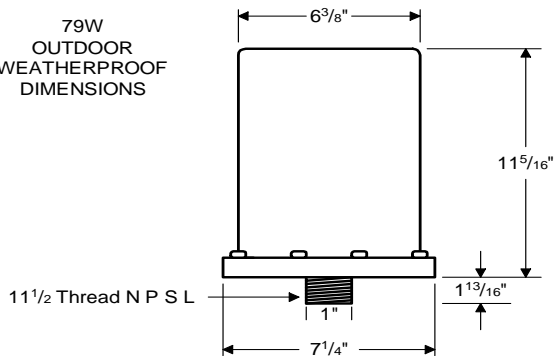

INPUT VOLTS	120	208	240	277	
CIRCUIT TYPE	CWA				
POWER FACTOR (min)	90%				
REGULATION					
Line Volts	±10%				
Lamp Watts	±10%				
LINE CURRENT (Amps)					
Operating.....	9.00	5.20	4.50	3.90	
Open Circuit.....	4.50	2.70	2.30	2.20	
Starting.....	7.80	4.00	3.70	3.20	
UL TEMPERATURE RATINGS					
Insulation Class	H(180°C)				
Coil Temperature Code	1029				
MIN. AMBIENT STARTING TEMP.	-20°F or -30°C				
NOM. OPEN CIRCUIT VOLTAGE	430				
INPUT VOLTAGE AT LAMP DROPOUT.....	84	146	168	194	
INPUT WATTS	1080				
RECOMMENDED FUSE (Amps).....	20	15	10	10	
CORE and COIL					
Dimension (A)					
Dimension (B)					
Weight (lbs.)	33				
Lead Lengths	10"				
CAPACITOR REQUIREMENT					
Microfarads					
Volts (min.)					
Fault Current Withstand (amps)					
60 Hz TEST PROCEDURES (Refer to Advance Test Procedure for HID Ballasts - Form 1270)					
High Potential Test (Volts)					
1 minute	2000				
2 seconds	2500				
Open Circuit Voltage Test (Volts)	385-475				
Short-Circuit Current Test (Amps)					
Secondary Current	5.20-6.40				
Input Current.....	5.70-8.50	3.20-4.80	2.80-4.30	2.40-3.60	-

Capacitor:

The capacitor is included as part of the potted assembly.



Wiring Diagram:

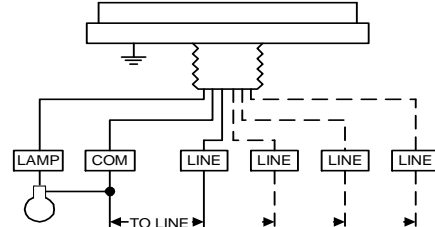

Fig. OW-2

**Ordering Information**

Order Suffix

Description

Ignitor:

NA

This ballast does not require the use of an ignitor.

Data is based upon tests performed by Advance Transformer in a controlled environment and representative of relative performance. Actual performance can vary depending on operating conditions. Specifications are subject to change without notice.

**ADVANCE TRANSFORMER CO.**

O'HARE INTERNATIONAL CENTER · 10275 WEST HIGGINS ROAD · ROSEMONT, IL 60018  
Customer Support/Technical Service: Phone: 800-372-3331 · Fax: 847-768-7768  
Corporate Offices: Phone: 800-322-2086

04/14/00