

**PHILIPS
ADVANCE**

LED Drivers

Quick Guide

Xitanium



Driver Solutions

**Versatility
delivered**

Philips Advance LED Drivers Quick Guide

Contents

Versatility Delivered	3
Programmable driver	4
Philips Advance Xitanium SR LED Drivers	5
Adjustable Output Current	7
Module Temperature Protection	8
Philips Advance Xitanium LED Driver Tc points	8
Remote mounting	9
Velocity unplugged: Simpleset Wireless Programming Technology	10
Catalog number explanation	12
Date codes	13
Philips Advance Xitanium LED Driver Categories	14
Outdoor LED drivers	14
Indoor downlight and LED track drivers	20
Indoor linear LED drivers	26
Accessories	29
Philips 277V Surge Protection Device	30
SP1 Surge Protection Device	32
SP1HV Surge Protection Device	33
MultiOne Configurator	34
Disclaimer	35
Footnotes	35

Versatility delivered

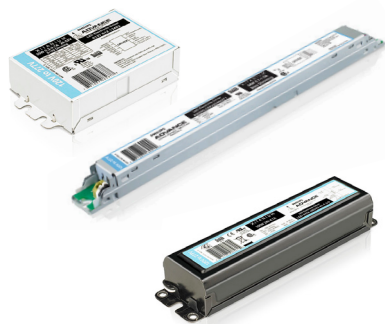

For optimal performance, long-lasting and low-maintenance LED Light Sources require reliable and long-lasting LED drivers matching the long lifetime of the LEDs. Our wide range of Philips Advance Xitanium LED Drivers are specially designed to operate LEDs in a variety of indoor and outdoor lighting applications and also meet a wide variety of customer needs, but they can all provide certain common benefits.

Including:

- Reliable and consistent operation
- High efficiency >90% in some cases
- Greater than 0.9 PF and less than 20% THD
- Greater than 50k hrs' lifetime
- 5-year limited warranty²
- ROHS compliance³
- Safety approbations (UL, CSA, CE, ENEC, PSE, SELV or CQC)

Philips Advance Xitanium LED Drivers are offered in the following categories:

Fixed

Fixed LED Drivers meet basic LED lighting needs with either dedicated input voltage or IntelliVolt option, to suit a wide variety of output current and power requirements.

Dimmable

Dimmable drivers address the growing demand for controllability and flexibility. The Adjustable Output Current (AOC) feature enables operation of various LED configurations from different LED

manufacturers and offers “future-proof” solutions for new LED generations. Specialized dimmable drivers enable use of lighting controls to increase energy saving through a wide variety of protocols, such as 0-10V and Trailing Edge (Step-Dim and Leading Edge coming soon). In most of the cases, the indoor drivers also integrate a 12V output for active cooling and NTC feedback for LED module temperature protection.

Additional dimmable LED Driver benefits:

- Wide variety of dimming interfaces (0-10V, Phase Cut, Step-Dim)
- Helps address code requirements for energy efficient buildings
- Fixture design flexibility through the AOC feature
- Options such as fan output and module temperature protection

Programmable driver



Optimized to meet the ever-evolving needs of today's LED lighting customers, Philips Advance Xitanium Programmable LED Drivers are a one-stop solution for the varying power needs of industrial high bay, office or retail lighting. Offering unparalleled flexibility, these drivers can be customized based on the desired functionality of the luminaire design with simple programming interface. With multiple choices for current output levels, module temperature control settings and a network-ready DALI interface, these drivers are an easily integrated driver solution. Luminaire designers and manufacturers are also able to streamline logistics without compromising on performance.

Speed up your business with new wireless programmable LED technology

Philips' new SimpleSet wireless programming technology for LED drivers is designed to help OEMs quickly and easily program LED

drivers at any time during the manufacturing, distribution or installation process. See page 8 for more information.

Additional programmable LED driver benefits:

- Robust programming that offers ultimate design flexibility with a reliable, long lifetime
- Reduced SKU complexity and simplified logistics management (one driver to serve many needs)
- Multiple dimming options provide energy savings and can help reduce light pollution and CO₂ impact
- Easily programmable user interface for onsite customization of driver requirements
- Optimized life expectancies of up to 100,000 hours⁴
- Driver programmability provides features for the ever-evolving improvements in LED efficacy, removing the need to design-in a new LED driver as technology improves or changes

Current Product Portfolio Positioning

	Point	Linear	Outdoor
Programmable	<ul style="list-style-type: none"> • Programmable solution • Reduced SKU complexity • Programmable features: CLO, AOC, MTP 	<ul style="list-style-type: none"> • Programmable solution • Reduced SKU complexity • Programmable features: CLO, AOC, MTP 	<ul style="list-style-type: none"> • Programmable solution • Reduced SKU complexity • Programmable features: CLO, AOC, MTP, OTL, AST, Dimming type (0-10V, DALI, AmpDim or Dynadimmer)
Dimmable	<ul style="list-style-type: none"> • Dimming interface options • AOC • MTP • Fan out for active cooling 	<ul style="list-style-type: none"> • Dimming interface options • AOC • MTP • SimpleSet 	<ul style="list-style-type: none"> • 0-10V dimming • AOC • MTP
Fixed	<ul style="list-style-type: none"> • Fixed output current • 50kHr lifetime⁴ • Connectors • Compact housing • Reliability 	<ul style="list-style-type: none"> • Fixed output current • 50kHr lifetime⁴ • Connectors • Linear housing • Reliability 	<ul style="list-style-type: none"> • Fixed output current • 50kHr lifetime (min)⁴ • High surge capability • Reliability

AOC: Adjustable Output Current
MTP: Module Temperature Protection

CLO: Constant Light Output
OTL: Over The Life

AST: Adjustable Startup Time

Philips Advance Xtanium SR LED Drivers

Uncomplicated and amenable to any sensor or network

In today's digital age, people can gather real-time data and use it to make highly informed decisions in areas from personal finance to time management and much more. However, this method of detailed insight is not relegated to personal use. In fact, it's now possible to wirelessly harvest specific, real-time lighting information in commercial spaces.

Philips Advance Xtanium SR LED Drivers streamline wireless connected lighting. They reduce overall costs by standardizing the digital connection between the driver and sensor, bundling important functionality into the driver and eliminating the need for auxiliary components. Xtanium SR Drivers enable power reporting and dim-to-off functionality at each fixture.

This streamlined approach and easy design-in means that OEMs can spend less time and money to bring products to market. And for your customers, Xtanium SR LED Drivers enhance energy efficiency by monitoring real-time system data and making this information available at any time to the network. It also manages sensors and commands related to occupancy, daylight harvesting and dim-to-off at each luminaire. Together with Philips, it's never been easier to create robust, cutting-edge wireless lighting solutions.

Simplicity for everyone

Using our Xtanium SR LED Drivers, digital system data is collected at each luminaire and then routed wirelessly through your customers' preferred networks. This means that very specific and actionable data can be used to make informed business decisions and optimize resource distribution within workspaces.

Simplified Luminaire Design

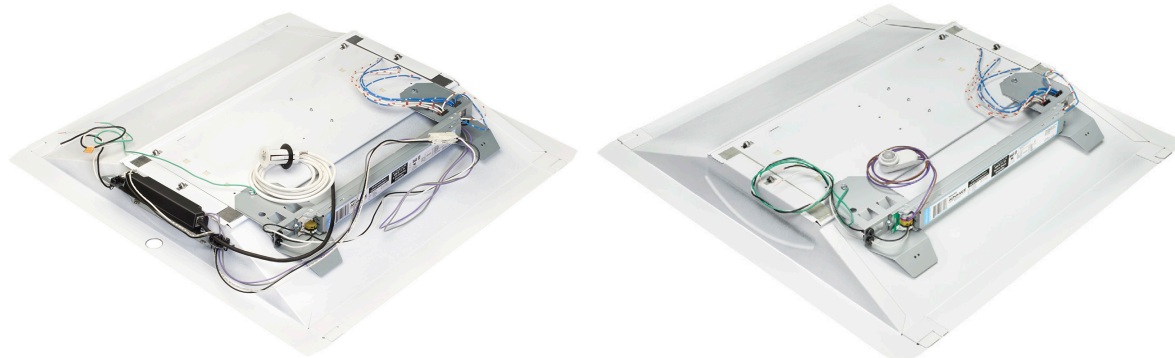

Separate components add unnecessary complexity to luminaires (left), while Xtanium SR LED Drivers integrate many of the components (right) for a streamlined luminaire design.



Xitanium SR and OEMs: The foundation for a successful partnership

Trust Philips Advance Xitanium SR LED Drivers to help reduce complexity and streamline your luminaire manufacturing processes, with:

- **Streamlined design** – no need for auxiliary component costs and management of excessive parts and pieces, simple 2-wire connection to the sensor.
- **Drop-in design, Xitanium footprint** – faster time to get your products to market.
- **Wireless luminaire-based data collection** – gather valuable sensing data, send it directly to the cloud or network of your choice.
- **UL recognized, CSA and RoHS compliant** – minimize the time and cost of approbations.
- **Low standby power**
- **DC power to sensors** – eliminates the need for redundant auxiliary components.
- **SimpleSet wireless programming technology** – quickly and wirelessly program the driver at any time without cumbersome wires or time-consuming manual methods.

Visit www.philips.com/xitaniumsr or call your local Philips sales representative for more information.

Adjustable Output Current

Adjustable Output Current (AOC) is a means of setting the secondary drive current of the LED driver to a prescribed level. This is determined by the OEM during fixture design to create desired illumination level and is not intended for field modification. The desired current level is set by adding an external resistance across two terminals identified on the LED driver as “RSET” and “SGND.” The data sheets for applicable drivers include a table and graph that correlates desired drive current to a specific resistance value. Additional specifications on resistor type is also included. Resistors with >0.25W and >20V are typically acceptable.

The resistor is furnished by the OEM and can be connected separately or incorporated elsewhere in the system (e.g., on the LED module). Two different current vs. resistance curves are used in these drivers, referred to as RSET1 and RSET2. RSET1 has a maximum current rating of 700mA (no resistance across the specified terminals). RSET2 has a maximum current rating of 2000mA (no resistance across the specified terminals).

AOC enables:

- Flexibility to select specific drive currents to optimize fixture performance
- Ability to consolidate SKUs and use one driver for multiple fixtures
- Ability to upgrade light engines and use the same driver, hence reducing qualification time and cost

Rset vs. Driver Current

Rset (Ohms)	Current (mA)
100	100
120	111
150	124.5
180	138.2
220	154.6
270	176.4
330	203.7
390	228.3
470	261.0
560	296.5
680	340.2
1000	452.1

Rset (Ohms)	Current (mA)
1000	452.1
1200	514.9
1500	602.3
1800	684.2
2200	779.7
2700	883.5
3300	992.7
3900	1085.5
4700	1191.9
5600	1273.0
6800	1402.1
8200	1503.1
>8200	1503.1

Typical AOC application:

54W Linear Driver XI054C150V054DNT1

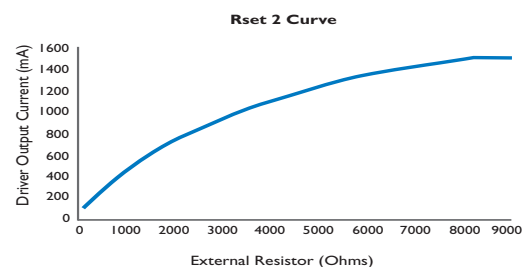

Example wiring diagram



Module Temperature Protection

Module Temperature Protection (MTP) allows an OEM to design the LED system to reduce drive current in the event that the module overheats, thus reducing heat and potentially avoiding failure. This is enabled by adding an external Negative Temperature Coefficient (NTC) across two terminals identified on the LED driver as “NTC” and “SGND.” When activated in application – by reaching the minimum temperature appropriate for the given NTC – drive current reduces according to the temperature-current curve of the specific NTC. The datasheets for applicable drivers include a graph illustrating current output vs. NTC resistance and also typically include an example graph of module temperature vs. current output using a specific NTC.

Module Temperature Protection enables:

- Enhanced protection of the LED system from misapplication (e.g., day-burning)
- Longer potential life expectancy of the LED system

Typical MTP application:

50W Downlight Driver XI050C100V054DNM1

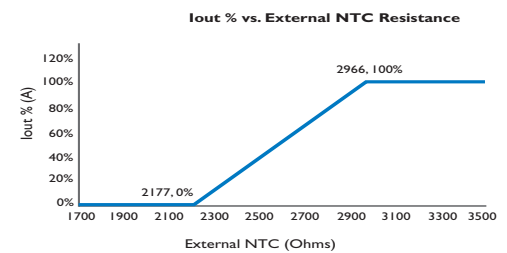

Example wiring diagram

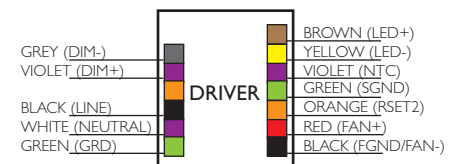

Philips Advance Xitanium LED Driver Tc points

The lifetime of LED drivers depends on the temperature during operation. This means there is a relationship between the Tc point on the LED driver and its lifetime. With this in mind, several diagrams have been made to aid in pinpointing the general area of the Tc point on the driver(s). Each driver has a designated diagram. For complete details on Tc Point, please contact your local Philips sales representative.

Remote mounting

Most LED drivers are utilized in self-contained fixtures where the driver is included within the fixture, which is considered an electrical enclosure. Some applications call for remote mounting of the driver whereby the driver is in a separate electrical enclosure and not within the same enclosure/fixture as the LED light source. In these applications, it is typically acceptable to have the driver remote mounted, but care is required to ensure that voltage drop is minimized to not impact performance of the LED system.

In general, larger gauge wires enable longer maximum distances, and higher LED drive currents have lower maximum distances. Published maximum wiring distances are typically based on full load, and longer distances are usually practical for lower load levels. Consult your Philips sales representative for complete information.

Typical remote mounting application:

100W Outdoor Driver LEDINTA0024V41FO

Wire Size (AWG)	Distance (feet)
26	3
24	4
22	7
20	11
18	18
16	29
14	46
12	71
10	120

Example wiring diagram

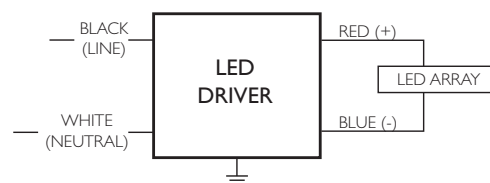

See footnote on page 35.

Velocity unplugged

Wireless programming for Xitanium Drivers

Philips Advance Xitanium LED Drivers with SimpleSet technology are designed to help OEMs quickly and easily program LED drivers at any time during the manufacturing, distribution or installation process. As a result, OEMs and their customers can meet orders faster with greater confidence while potentially reducing costs and inventory.

Accelerate LED programming

Currently, there are a variety of methods used to adjust output current of LED drivers. One method is putting a resistor on the driver that allows you to set the desired drive current. Other methods include DIP switches, adjustable potentiometers or programming via software. These solutions are cumbersome to incorporate into high volume production environments because the driver either has to be powered for programming or needs to be wired to a programming device.

Using our Xitanium LED Drivers with SimpleSet technology, you will be able to quickly and easily program drive current and set specific lumen levels without the driver being powered or wired. This speed and flexibility will allow you and your customers to set and reset parameters as needed.

Accelerate LED programming

1. Take the driver out of the box. Locate the designated communication area on the driver.



2. Touch the LED driver to the programming device. Programming confirmation will appear on the monitor.

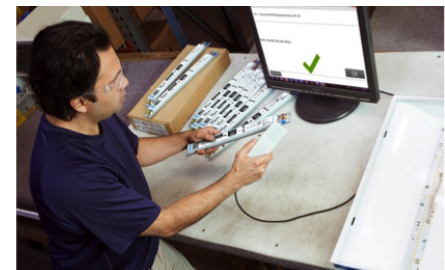

3. Install the driver into the fixture.



Benefits of wireless programming:

Speed – Program fixtures faster without requiring complex and time-consuming wiring mechanics or powering up drivers.

Flexibility – Program at any stage in the manufacturing process, either single components or multiple drivers at once.

Reduced costs – Meet a diverse set of customer needs without over-extending your SKUs or managing different driver SKUs.

Simplicity – Deploy anywhere in the assembly process without complex training; intuitive for anyone in the value chain, regardless of experience.

Security – Set and protect proprietary information with dedicated memory space for OEMs with password protection.

Stay ahead of business demands

SimpleSet technology enables you to do more for your customers and your business. OEMs can quickly meet a broad range of customer requirements and order variations. In addition, wireless programming is flexible so it can be incorporated directly into any and all areas of your product development process, warehouse and distribution. You have never-before-possibilities to create differentiation for your business.

The first parameter available for wireless programming will be drive current, with additional options to follow.

Visit www.philips.com/simpleset or call your local Philips sales representative for more information.

Programmer PN: LCN9600



Catalog number explanation

Prior to January 2011

LED	INT	A	C035	V	425	DN	M
							Packaging: M=Midpack, I=Individual Pack, B=Bulk Pack
							Fixed or Dimming: FO=Fixed DO=Dimming (0-10V) Isolated DN=Dimming (0-10V) NON-Isolated
							DL=Dimming (0-10V) NON-Isolated in F-can F3=Tritap FL=Fixed in F-can
							Max Voltage or Max Current: 210=210V 24=24V 30=3.0A 425=425V 07=0.7A 32=3.2A 140=140V 21=2.1A 41=4.1A 280=280V 14=1.4A 24=24V 80=80V 20=2.0A 60=60V 33=3.3A 22=2.2A 80=80V 28=2.8A 36=36V 18=1.8A 10=1.0A 50=5.0A
							Constant Current or Constant Voltage: C= Constant Current V= Constant Voltage
							Max Current or Max Voltage: 0350=350mA 1050=1.05A 0036=36V 1600=1.6A 0400=400mA 2000=2.0A 700=700mA 1000=1.0A 0530=530mA 0024=24V 0520=520mA 0700=700mA 0012=12V 0520=520mA
							Input Voltage: A=AC Voltage D=DC Voltage
							Input Voltage: INT=120 - 277V (UL, CSA) UNI=120 - 240V 120=120V (UL, CSA) HCN=347-480V (UL, CSA) 277=277V (UL, CSA)
General: LED= Xitanium LED Driver							

After January 2011

X	I	075	C070	V105	C	N	Y	1	M
									Packaging: M=Midpack, I=Individual Pack, B=Bulk Pack
									Version Control: 1=Version 1, 2=Version 2, ...
									Enclosure Designation
									Features: P=Programming S=SimpleSet N=Non-Programming
									Fixed or Dimming: B=0-10V, AOC L=DALI C=0-10V R=Leading Edge & Trailing Edge Dimming D=0-10V, AOC, MTP S=Step Dim F=Fixed V=SensorReady K=DLI, 0-10V, MTP
									Max Voltage: Examples: 012=12V, 054=54V, 280=280V
									Max Current: Examples: 035=350mA, 070=700mA, 053=530mA, 105=1050mA
									Max Power: Examples: 025=25W, 060=60W, 300=300W
									Input Voltage: I=120-277V G=347V R=120V H=347-480V V=277V

General:
 X= Xitanium LED

Date codes

Most date codes are stamped on the back of the driver (opposite the label side). The date code is part of a larger group of numbers and letter, that call out the various codes for the factory where the driver was manufactured. Depending upon which Philips Lighting factory manufactured the driver, the date stamp can vary slightly in terms of its position on the driver and the number sequence.

For plastic case drivers the date code will appear as a label.

693POMMA
 53301707

The date code is the 5th day of the 33rd week of 2001 stamped on the back of the ballast.

06127M50
 F2104571

The date code is the 127th day of 2006 stamped on the back of the ballast.

Philips Advance Xitanium outdoor LED drivers



Xitanium LED Drivers for outdoor applications are available in three types:

Fixed output

Fixed output LED drivers set the standard for reliability and performance needed for outdoor lighting.

Dimming

Dimmable LED drivers include 0-10V dimming as well as Adjustable Output Current (AOC) and Module Temperature Protection (MTP). These help address the growing demand for controllability and flexibility. 0-10V dimming allows the lighting system to be used with various controls for maximizing energy savings. AOC enables the OEM to maximize performance of the fixture and provides flexibility for use in multiple fixtures. MTP further enhances life and reliability in the event of misapplication.

Programmable

Programmable LED drivers offer unparalleled flexibility with the ultimate feature set managed through a programmable interface. This allows the OEM to create a fixture portfolio to meet specific needs for a wide range of applications, using a minimum number SKUs to reduce complexity and simplify logistics.

These drivers are available in wattages of 40W to 150W for hard-wired integration into outdoor luminaires for the most rugged applications. They operate to specification under wide temperature and electrical ranges to ensure reliability.

Specific features of this series are:

- Standard drive currents 350, 530, 700, 1050 and 1500mA
- UL Class 1 or Class 2
- Input voltage ranges of 120-277V or 347-480V
- Surge protection
- High efficiency for maximum payback
- High reliability for low maintenance costs

Applications include:

- Area
- Roadway
- Parking garage
- Gas station canopy
- Wallpacks
- Floodlights

Outdoor Drivers Fixed

Catalog	Max Output Power (W)	Output Voltage (V)	Output	Input Voltage (Vac)	UL/ CSA Class 2	Dimming					Features				Dim./ Wiring Dia.	Max Tc case (°C)
						0-10V	TE	LE	Step Dim	DALI	AOC	MTP	CLO	Others		
LED120A0350C28FO	10	2.8 - 28	0.35	120	•										V-Can/1	90
LED120A0012V10F	12	12	1	120	•										V-Can/1	90
LED120A0700C24FO	17	2.8 - 24	0.7	120	•										V-Can/1	90
LED120A0700C28FO	20	2.8 - 28	0.7	120	•										V-Can/1	90
LED277A0700C28FO	20	2.8 - 28	0.7	277	•										V-Can/1	90
LED120A0024V14FO	34	2.8 - 24	1.4	120	•										J-Box/1	90
LED120A0024V18FO	40	2.8 - 24	1.75	120	•										J-Box/1	90
LEDINTA0024V20FLO	48	24	0.10 - 2.0	120 - 277	•										F-Can Bump/1	85
LEDINTA0024V22FO	53	24	2.2	120 - 277	•										S-Can/1	90
LED120A0012V50F	60	12	0.8 - 5.0	120	•										S-Can/1	90
LEDINTA0012V50FO	60	12	0.10 - 5.0	120 - 277	•										S-Can/1	90
LEDINTA0024V28FO	67	24	0.10 - 2.8	120 - 277	•										S-Can/1	90
LEDINTA0024V30FLO	72	24	0.10 - 3.0	120 - 277	•										F-Can Bump/1	85
LEDINTA0024V32FO	77	24	3.2	120 - 277	•										S-Can/1	90
LED120A0024V33F	80	24	0.8 - 3.3	120	•										S-Can/1	90
LEDINTA0024V33F	80	24	0.8 - 3.3	120	•										S-Can/1	90
LEDINTA700C140F30	100	60 - 140	0.35/0.53/0.70	120 - 277											F-Can Bump/6	80
XI100C230V042FNS1	100	21 - 42	2.30	120 - 277	•										S-Can/1	90
LEDHCNA0024V41FLO	100	3.5 - 24	0.10 - 4.16	347 - 480	•										F-Can Bump/1	85
LEDINTA0024V41FLO	100	3.5 - 24	0.10 - 4.16	120 - 277	•										F-Can Bump/1	85
LEDINTA0024V41FO	100	3.5 - 24	0.10 - 4.16	120 - 277	•										S-Can/1	90
LEDHCNA0350C-425FO	150	120 - 425	0.35	347 - 480											F-Can Bump/1	80
LEDINTA0350C425FO	150	120 - 425	0.35	120 - 277											F-Can Bump/1	80
XH150C070V210FNF1	150	60 - 210	0.7	347 - 480											F-Can Gen 2/1	80
LEDINTA0700C210FO	150	60 - 210	0.7	120 - 277											F-Can Bump/1	90

Outdoor Drivers Dimmable

Catalog	Max Output Power (W)	Output Voltage (V)	Output Current (A)	Input Voltage (Vac)	UL/ CSA Class 2	Dimming					Features				Dim./ Wiring Dia.	Max Tc case (°C)
						0-10V	TE	LE	Step Dim	DALI	AOC	MTP	CLO	Others		
LED120A0700C28DO	20	10 - 28	0.7	120	•	•									V-Can/2	90
LED277A0700C30DO	21	15 - 30	0.7	277	•	•									V-Can/2	80
XI040C070V056CNJ1	40	12 - 54	0.7	120 - 277	•	•									J-Can/2	80
XI040C105V042CNJ1	40	14 - 42	1.05	120 - 277	•	•									J-Can/2	80
XI040C120V035CNJ1	40	12 - 36	1.2	120 - 277	•	•									J-Can/2	80
LEDINTA0024V20DLO	48	24	2	120 - 277	•	•									F-Can Bump/2	85
XI050C150V038CNH1	50	19 - 38	1.5	120 - 277	•	•									H-Can/2	80
LEDINTA0024V30DLO	72	24	3	120 - 277	•	•									F-Can Bump/2	85
XI075C053V140CNY1	75	71 - 143	0.53	120 - 277		•									Y-Can/2	80
XI075C053V140DNY1	75	71 - 143	0.10 - 0.53	120 - 277		•					•	•			Y-Can/3	80
XI075C070V105CNY2	75	54 - 107	0.7	120 - 277		•									Y-Can Gen 2/2	80

Outdoor Drivers Dimmable – Continued

Catalog	Max Output Power (W)	Output Voltage (V)	Output Current (A)	Input Voltage (Vac)	UL/ CSA Class 2	Dimming					Features				Dim./ Wiring Dia.	Max Tcase (°C)
						0-10V	TE	LE	Step Dim	DALI	AOC	MTP	CLO	Others		
XI075C070V105DNY1	75	54 - 107	0.10 - 0.70	120 - 277		•					•	•			Y-Can/3	80
929000708003	75	54 - 107	0.10 - 0.70	120 - 277		•					•	•		CE	Y-Can/3	80
XI075C105V070CNY2	75	36 - 72	1.05	120 - 277		•									Y-Can Gen 2/2	80
XH075C105V070CNF1	75	24 - 71	1.05	347-480		•									F-Can Gen 2/2	80
XI100C150V038CNH1	100 (2x50)	19 - 38	1.5	120 - 277	•	•								2-ch	H-Can/4	80
XI100C230V042CNS1	100	21 - 41	2.3	120 - 277	•	•									S-Can/2	90
LEDINTA0024V41DLO	100	15 - 24	4.1	120 - 277	•	•									F-Can Bump/2	85
LEDHCNA0024V41DLO	100	15 - 24	4.1	347 - 480	•	•									F-Can Bump/2	85
LEDINTA0350C425DO	150	120 - 425	0.35	120 - 277		•									F-Can Bump/2	80
LEDHC-NA0350C425DN	150	120 - 425	0.35	347 - 480		•									F-Can Bump/2	80
LEDINTA0530C280DO	150	120 - 280	0.53	120 - 277		•									F-Can Bump/2	80
XH150C053C280CNF1	150	120 - 280	0.53	347 - 480		•									F-Can Gen 2/2	80
LEDINTA0700C210DO	150	60 - 210	0.7	120 - 277		•									F-Can Bump/2	90
XH150C070C210CNF1	150	60 - 210	0.7	347 - 480		•									F-Can Gen 2/2	80
XI150C105V140CNF1	150	40 - 140	1.05	120 - 277		•									F-Can Gen 2/2	80
XH150C105V140CNF1	150	47 - 142	1.05	347 - 480		•									F-Can Gen 2/2	80
LEDINTA1500C100DO	150	30 - 100	1.5	120 - 277		•									F-Can Bump/2	80

Outdoor Drivers Programmable

Catalog	Max Output Power (W)	Output Voltage (V)	Output Current (A)	Input Voltage (Vac)	UL/ CSA Class 2	Dimming					Features				Dim./ Wiring Dia.	Max Tcase (°C)
						0-10V	TE	LE	Step Dim	DALI	AOC	MTP	CLO	Others		
929000708803	40	29 - 57	0.10 - 0.70	120 - 277		•				•	•	•	•	•	J-Can/5	80
929000710303	40	38 - 76	0.10 - 0.53	120 - 277		•				•	•	•	•	•	J-Can/5	80
929000702302	75	80 - 152	0.35 - 0.70	120 - 277		•				•	•	•	•	•	F-Can Flat/5	80
929000704913	75	80 - 152	0.35 - 0.70	120 - 277		•				•	•	•	•	•	F-Can Flat/5	80
929000710103	75	54 - 107	0.10 - 0.70	120 - 277		•				•	•	•	•	•	Z-Can/5	80
929000708903	75	36 - 75	0.10 - 1.05	120 - 277		•				•	•	•	•	•	F-Can Flat/5	80
XH075C120V075KPF1	75	25 - 75	0.3 - 1.20	347 - 480		•				•	•	•	•	•	F-Can Chassis mount/7	80
929000710403	100	94 - 189	0.10 - 0.53	120 - 277		•				•	•	•	•	•	Z-Can/5	80
929000708703	100	71 - 143	0.10 - 0.70	120 - 277		•				•	•	•	•	•	Z-Can/5	80
XI150C035V425MPH1	150	212 - 425	0.2 - 0.35	120 - 277		•				•	•	•	•	•	H-Can/5	80
929000702202	150	125 - 280	0.35 - 0.70	120 - 277		•				•	•	•	•	•	F-Can Flat/5	80
929000705113	150	125 - 280	0.35 - 0.70	120 - 277		•				•	•	•	•	•	F-Can Flat/5	80
929000709003	150	70 - 148	0.10 - 1.05	120 - 277		•				•	•	•	•	•	F-Can Flat/5	80
XH150C120V150KPF1	150	50 - 150	0.35 - 1.20	347 - 480		•				•	•	•	•	•	F-Can Chassis mount/7	85

Outdoor Driver Dimensions

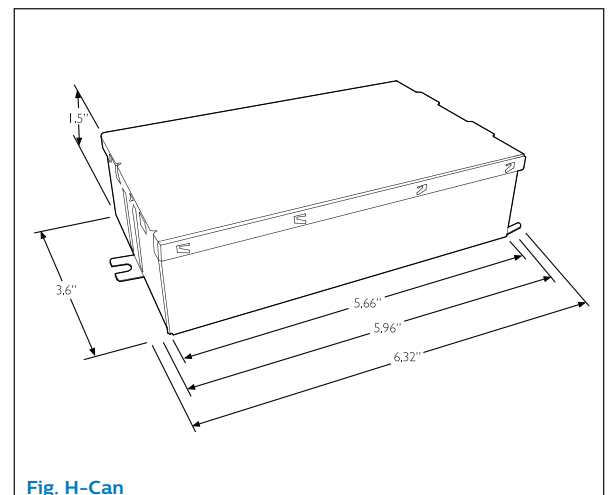
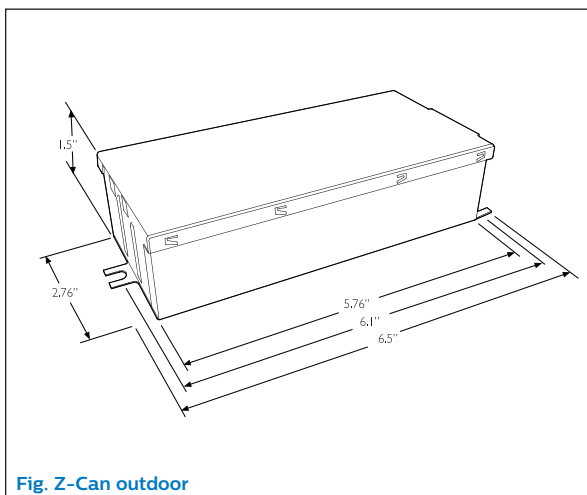
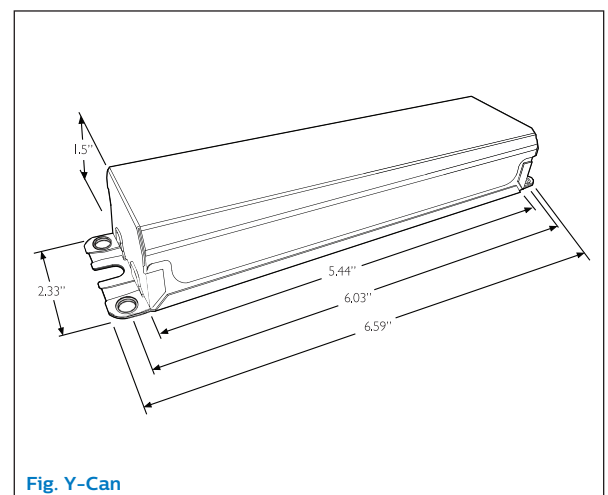
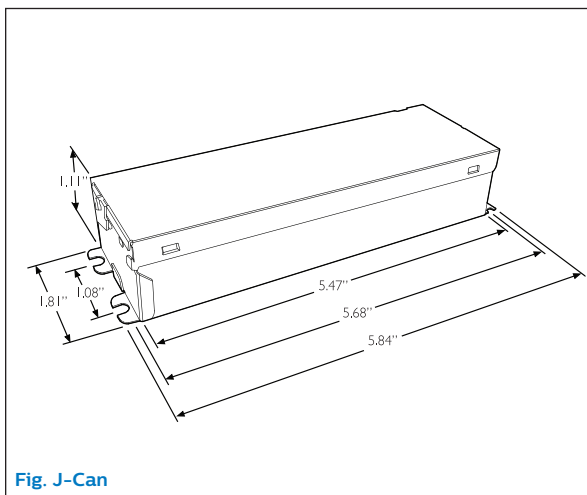
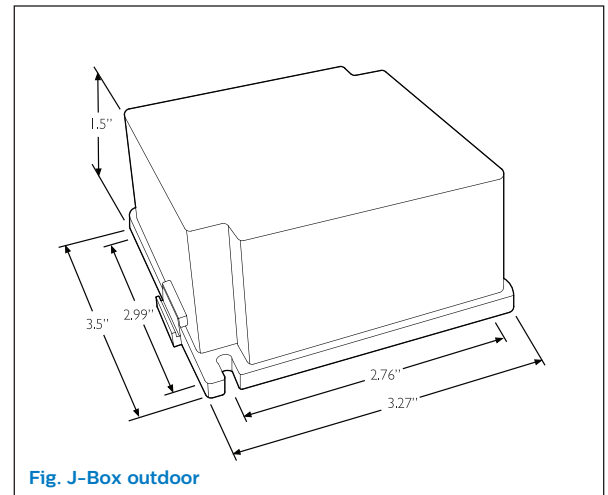
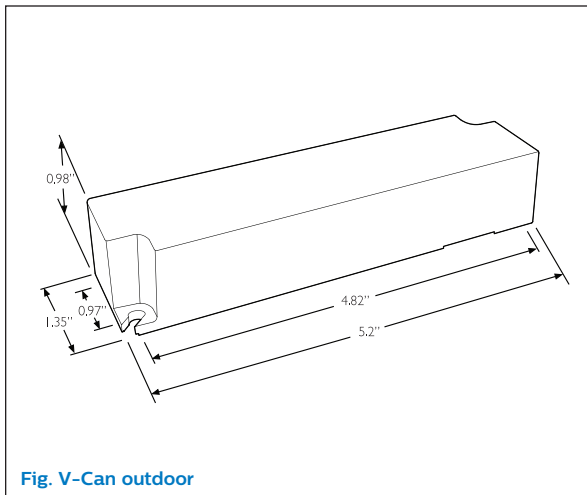

Outdoor Driver Dimensions

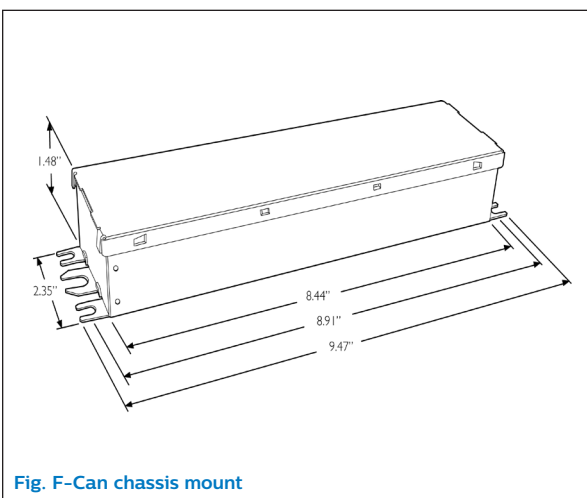
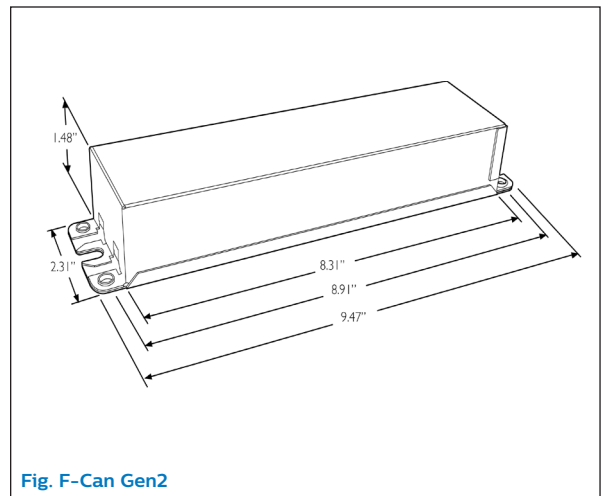
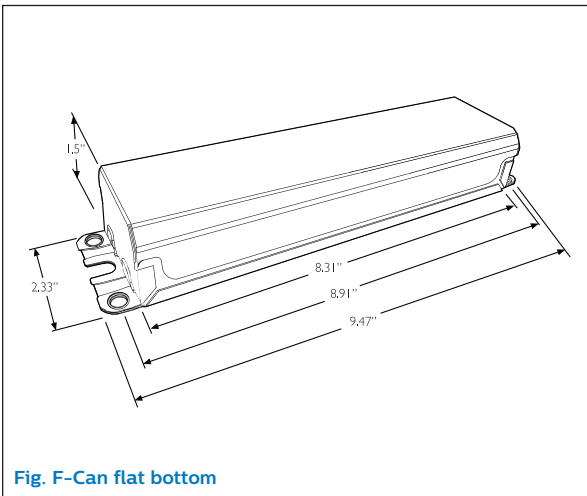
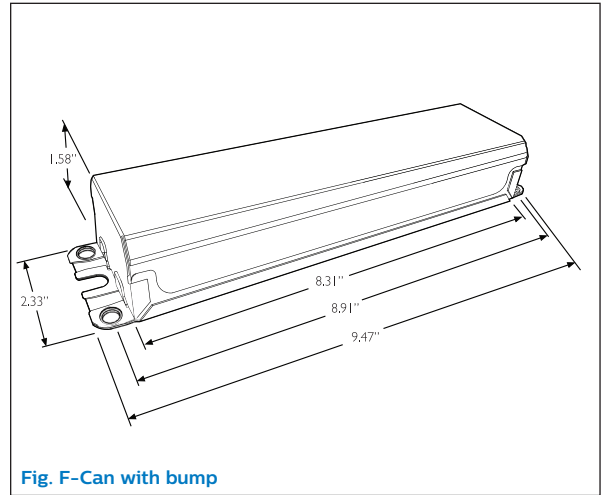
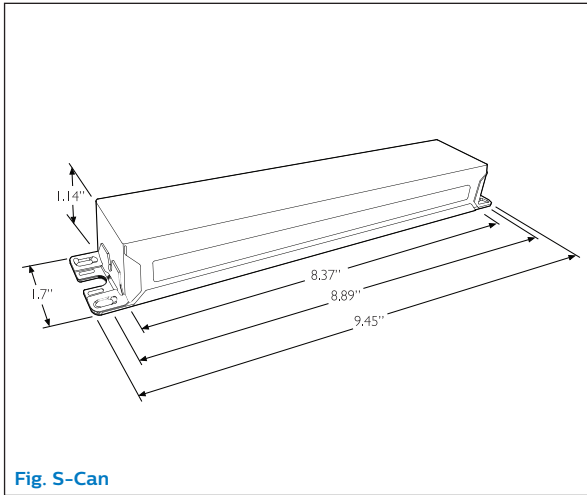

Outdoor Driver Wiring Diagrams

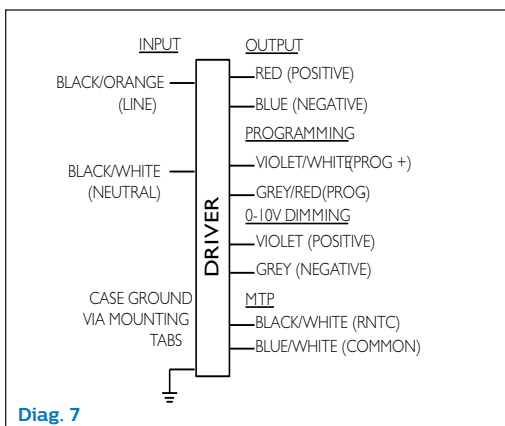
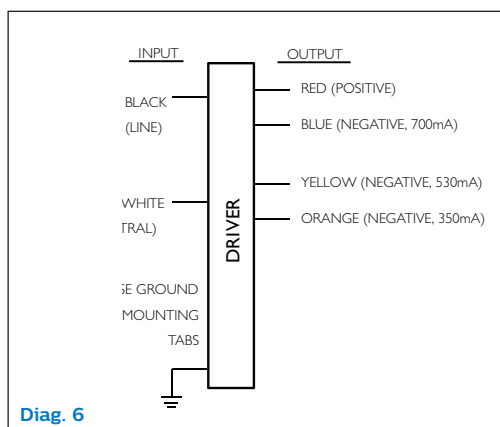
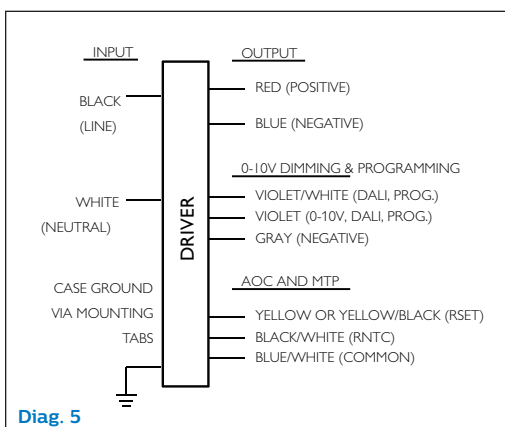
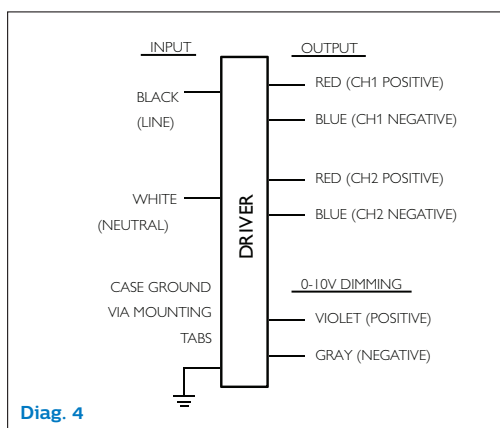
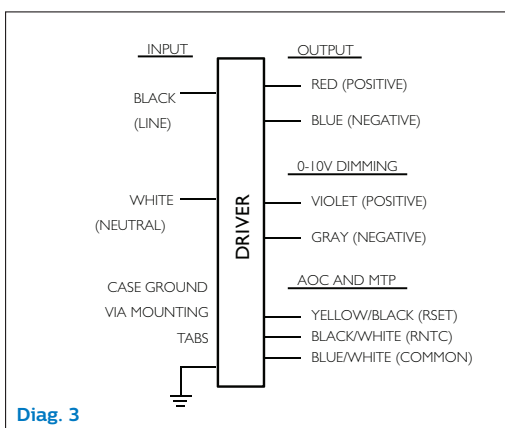
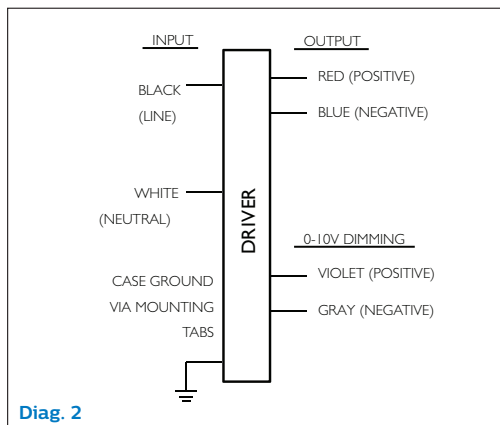
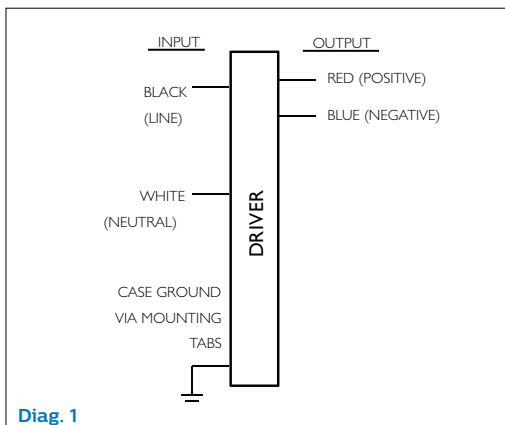

Indoor downlight and LED track drivers



Philips Advance Xitanium LED Drivers for indoor downlight and track applications are available in three types:

Fixed output

Fixed output LED drivers set the standard for reliability and performance needed for indoor downlight and track lighting.

Dimming

Dimmable drivers include 0-10V or leading/trailing-edge dimming to integrate into common dimming systems used in commercial applications. Dimming enables maximum energy savings and can help to facilitate worker comfort.

Programmable

These drivers offer unparalleled flexibility with the ultimate feature set managed through a programmable interface. This allows the OEM to create a fixture portfolio to meet specific needs for a wide range of applications, using a minimum number of SKUs to reduce complexity and simplify logistics.

The drivers are available in 4W to 50W for hard-wired integration into recessed downlights and track light fixtures. These LED Drivers are available in the familiar SmartMate housing for junction-box mounting in downlights and slim housings for incorporation into track housings.

Specific features of this series are:

- Adjustable output current
- Wide operating windows
- UL Class 1 or Class 2
- Input voltage range of 120-277V
- High efficiency for maximum payback
- High reliability for low maintenance costs

Applications include:

- Office
- Retail
- Hospitality
- Meeting rooms

.....
Indoor downlight
and LED
track drivers
.....

Downlight/Track Drivers - Fixed

Catalog	Max Output Power (W)	Output	Output Current (Amps)	Input Volts	UL/ CSA Class 2	Dimming					Features					Dim./ Wiring Dia.	Max Tcase (°C)
						0-10V	TE	LE	Step Dim	DALI	AOC	MTP	CLO	Fan	Others		
LEDUNIA0350C12F	4	2.8 - 12	0.35	120 - 230	•											8W/1	69
LEDUNIA0700C12F	8	2.4 - 12	0.7	120 - 230	•											8W/1	69
LED120A0024V07F	17	24	0.10 - 0.70	120	•											V-Can Indoor/13	80
LED120A0700C24F	17	2.8 - 24	0.7	120	•											V-Can Indoor/13	85
LED120A1400C24F	34	2.8 - 24	1.4	120	•											J-Box Indoor/21	85

Downlight/Track Drivers - Dimmable

Catalog	Max Output Power (W)	Output Voltage (V)	Output Current (Amps)	Input Volts	UL/ CSA Class 2	Dimming					Features					Dim./ Wiring Dia.	Max Tcase (°C)	
						0-10V	TE	LE	Step Dim	DALI	AOC	MTP	CLO	Fan	Others			
XI013C030V048DNM1	13	24 - 48	0.1 - 0.3	120 - 277	•	•						•	•				M1-Can/15	80
XI020C050V042RNP1	20	21 - 42	0.35/0.4/0.45/0.5	120 - 277	•		•	•				•	•				P-Can/13	80
XI020C070V030RNP1	20	15 - 30	0.4/0.5/0.6/0.7	120 - 277	•		•	•				•	•				P-Can/13	80
XI025C070V036DNM1	25	18 - 36	0.2 - 0.7	120 - 277	•	•						•	•				M5-Can/17	90
XI025C100V036DNM1	25	18 - 36	0.1 - 1.0	120 - 277	•	•						•	•				M1-Can/15	90
XI025C100V045DNM1	25	18 - 45	0.1 - 1.0	120 - 277	•	•						•	•				M1-Can/15	90
LEDINTA0520C60DB	30	25 - 56	0.35 - 0.52	120 - 277	•	•						•	•				M5-Can/17	77
XI036C100V048DNM1	36	20 - 48	0.1 - 1.0	120 - 277	•	•						•	•				M5-Can/15	90
913701213402	39	20 - 56	0.20 - 0.70	120 - 277	•	•						•	•		•		M5-Can/16	90
LEDINTA0520C80DB	40	40 - 77	0.35 - 0.52	120 - 277	•	•						•	•				M5-Can/17	74
XI050C100V054DNM1	50	27 - 54	0.3 - 1.0	120 - 277	•	•						•	•		•		M2-Can/14	75
LEDINTA1000C60DB	50	25 - 48	0.7 - 1.05	120 - 277	•	•						•	•				M5-Can/17	86
XI050C105V052DNM1	50	25 - 52	0.7 - 1.05	120 - 277	•	•						•	•				M5-Can/17	86

Downlight/Track Drivers - Programmable

Catalog	Max Output Power (W)	Output Voltage (V)	Output Current (Amps)	Input Volts	UL/ CSA Class 2	Dimming					Features					Dim./ Wiring Dia.	Max Tcase (°C)	
						0-10V	TE	LE	Step Dim	DALI	AOC	MTP	CLO	Fan	Others			
XV025C100V036DPM1	25	18 - 36	0.3 - 1.0	277	•	•						•	•	•	•		M2-Can/18	75
XR025C100V036XPM1	25	18 - 36	0.3 - 1.0	120	•	•	•					•	•	•	•		M2-Can/18	75
XR025C100V036LPM1	25	18 - 36	0.3 - 1.0	120	•						•	•	•	•			M2-Can/19	75
XI025C100V036XPL1	25	18 - 36	0.3 - 1.0	120 - 277	•	•	•					•	•	•	•		25W LH-Can/20	75
XV050C100V054DPM1	50	27 - 54	0.3 - 1.0	277	•	•						•	•	•	•		M2-Can/18	75
XR050C100V054XPM1	50	27 - 54	0.3 - 1.0	120	•	•	•					•	•	•	•		M2-Can/18	75
XI050C100V054XPL1	50	27 - 54	0.3 - 1.0	120 - 277	•	•	•					•	•	•	•		50W LH-Can/20	75

Downlight/Track Driver Dimensions

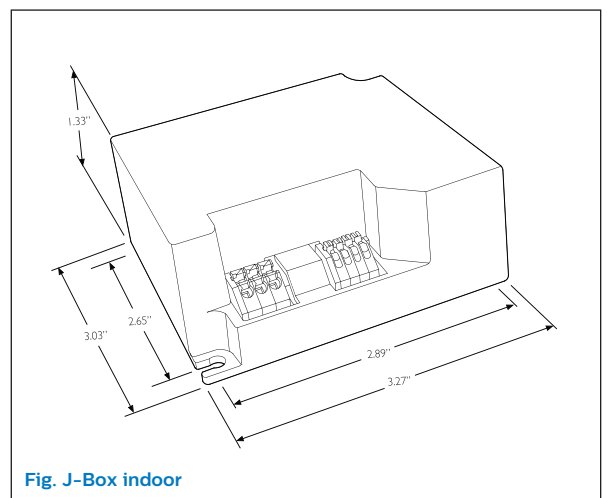
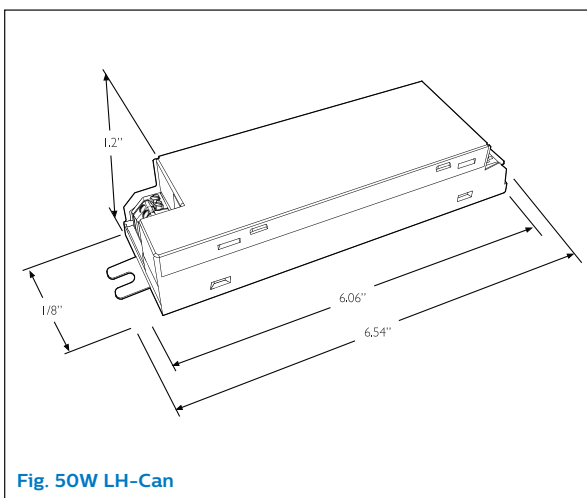
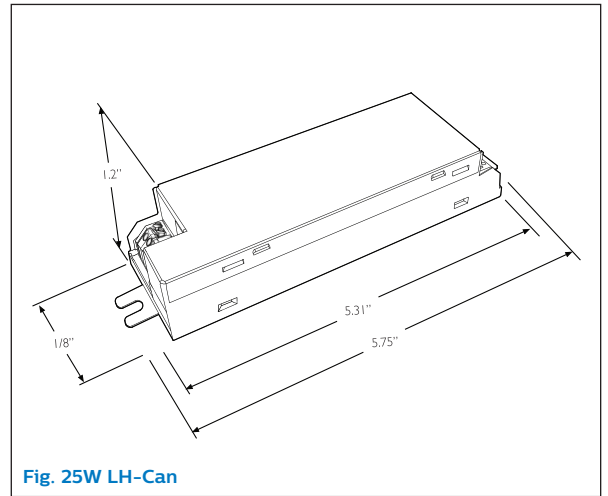
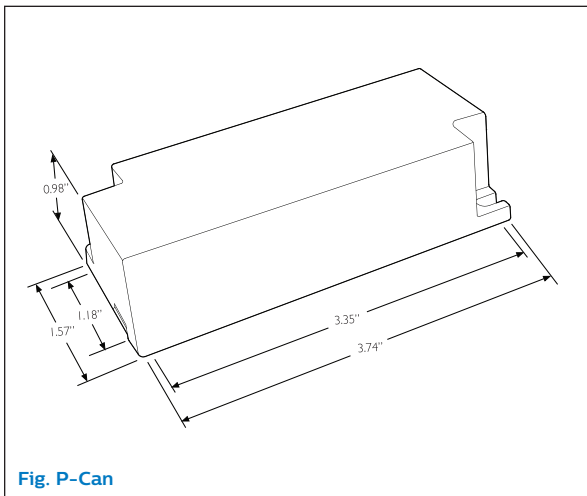
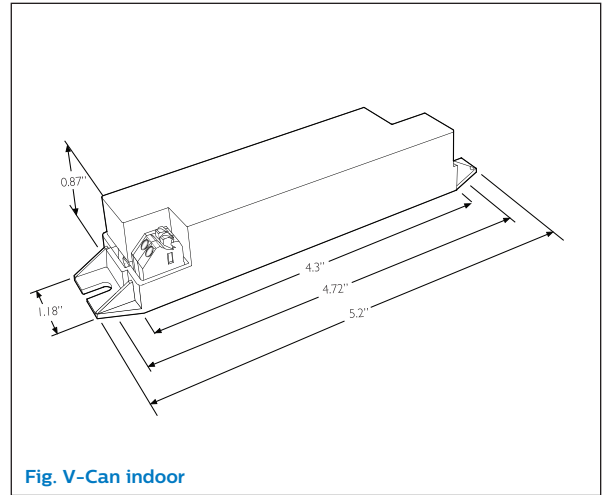
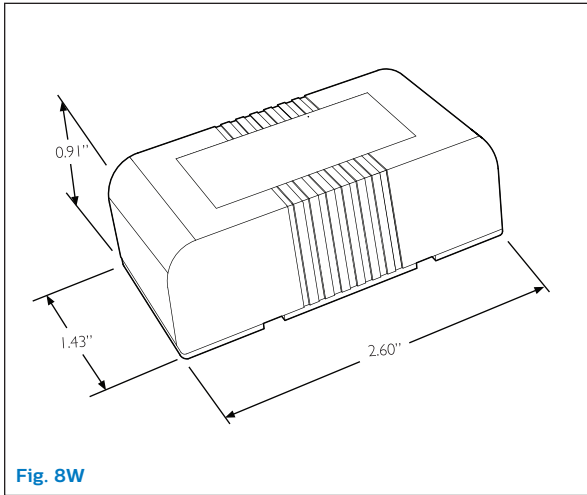

Downlight/Track Driver Dimensions

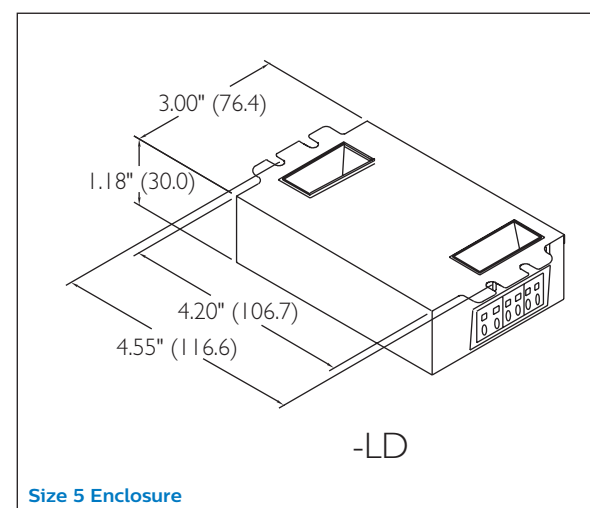
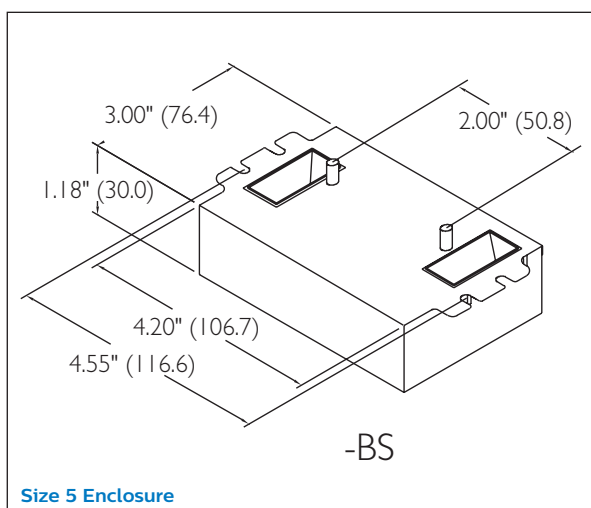
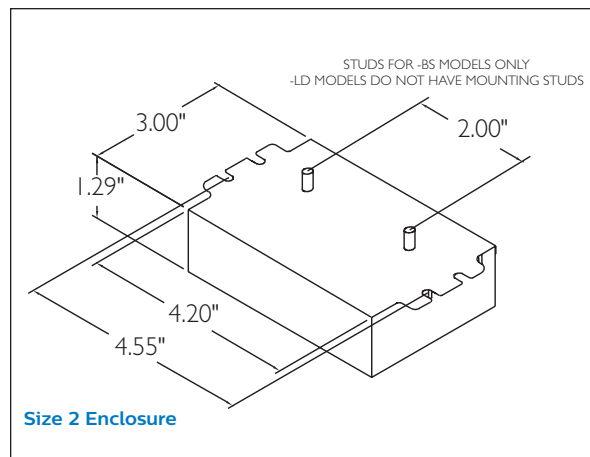
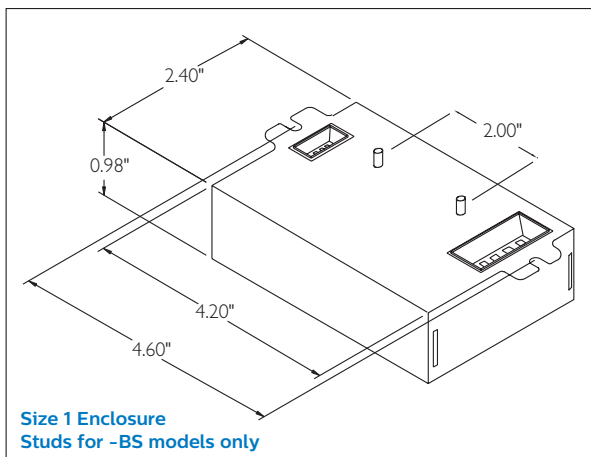

Downlight/Track Driver Wiring Diagrams

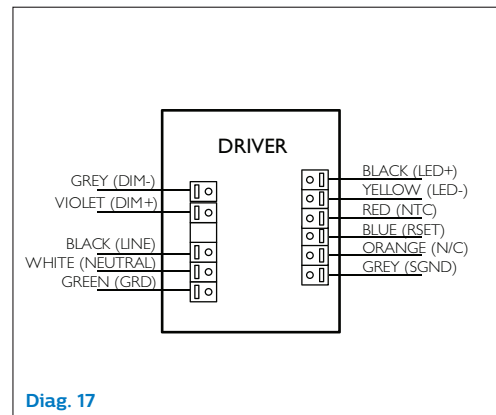
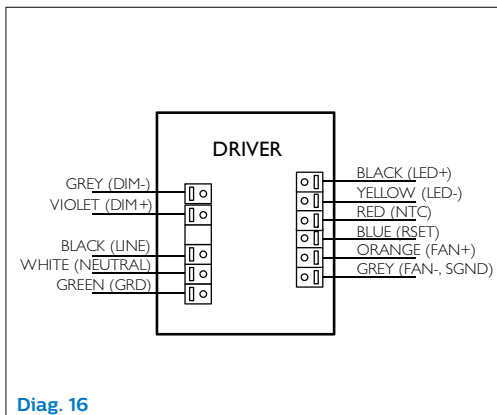
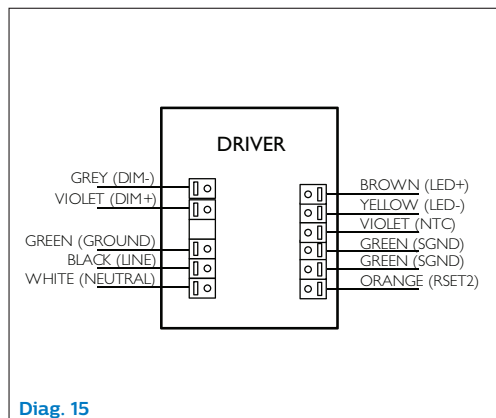
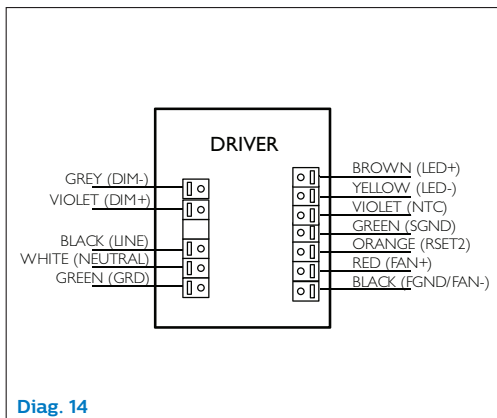
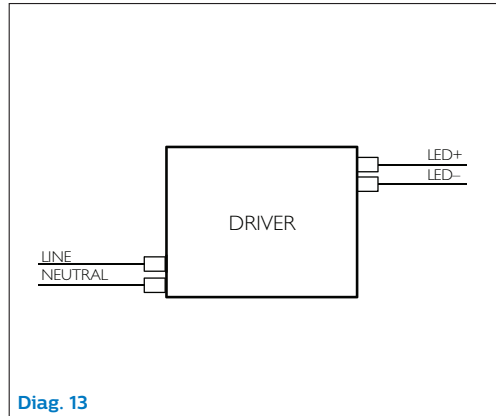
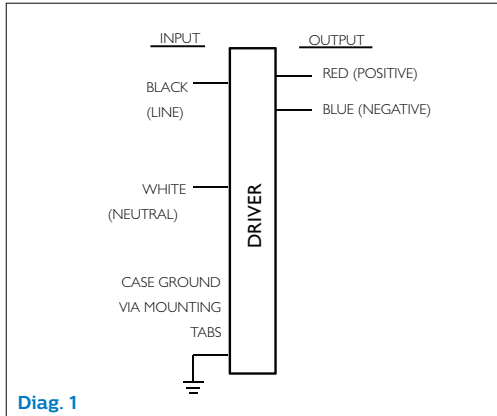

Downlight/Track Driver Wiring Diagrams

.....
 Indoor downlight
 and LED
 track drivers

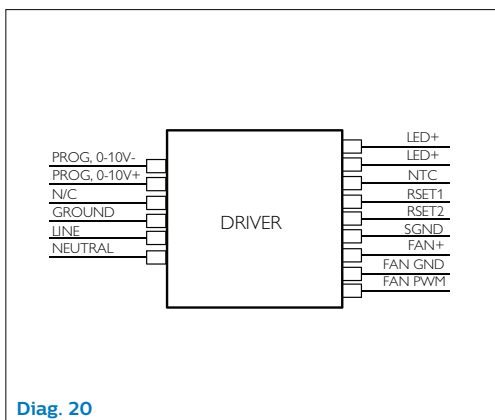
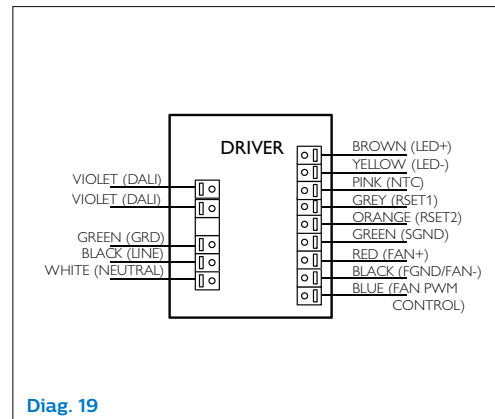
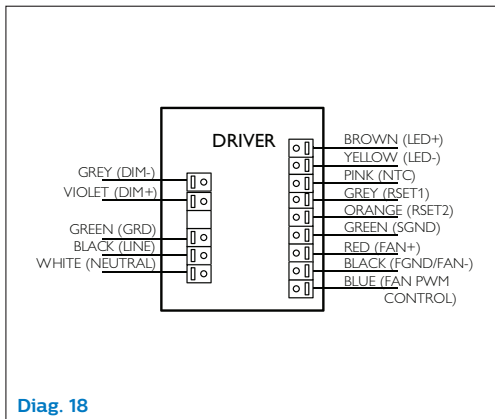

Indoor linear LED drivers



Philips Advance Xitanium LED Drivers for linear applications are available in three types:

Fixed output

Fixed output LED drivers set the standard for reliability and performance needed for linear lighting.

Dimming

Dimmable drivers include 0-10V or leading-edge dimming to integrate into common dimming systems used in commercial applications. Dimming enables maximum energy savings and can help to facilitate worker comfort.

Programmable

These drivers offer unparalleled flexibility with the ultimate feature set managed through a programmable interface. This allows the OEM to create a fixture portfolio to meet specific needs for a wide range of applications, using a minimum number SKUs to reduce complexity and simplify logistics.

These drivers are available 20W to 75W or hard-wired integration into linear fluorescent-style fixtures (troffers). The form factor is perfectly suited to these applications and enables quick time to market by utilizing mechanical aspects familiar in traditional fluorescent fixtures.

Specific features of this series are:

- Adjustable output current
- Wide operating windows
- UL Class Class 2
- Input voltage range of 120-277V
- High efficiency for maximum payback
- High reliability for low maintenance costs

Applications include:

- Office
- Retail
- Hospitality
- Meeting rooms

Linear Drivers – Dimmable

Catalog	Max Output Power (W)	Output Voltage (V)	Output Current (Amps)	Input Volts	UL/ CSA Class 2	Dimming					Features					Dim./ Wiring Dia.	Max Tcase (°C)
						0-10V	TE	LE	Step Dim	DALI	AOC	MTP	CLO	Fan	Others		
XI020C056V054BST1	20	27 - 54	0.1 - 0.56	120 - 277	•	•					•				Simple Set	T-254/13	80
XI040C110V054BPT1	40	27 - 54	0.1 - 1.1	120 - 277	•	•					•				Simple Set	T-360/13	85
LEDINTA2000C24DO	48	12 - 24	1.0 - 2.0	120 - 277	•	•					•					T-425	80
XI054C150V054DNT1	54	27 - 54	0.1 - 1.5	120 - 277	•	•					•	•				T-360/8	85
XI054C150V054SNT1	54	27 - 54	0.1 - 1.5	120 - 277	•			•			•	•				T-360/9	85
XR054C150V054RNT1	54	27 - 54	0.1 - 1.5	120	•			•			•	•				T-360/0	85
XV054C150V054RNT1	54	27 - 54	0.1 - 1.5	277	•			•			•	•				T-360/10	85
XI075C200V054BPT1	75	27 - 54	0.1 - 2.00	120-277	•	•					•				Simple Set	T-425/13	85
XI095C275V054DNF1	95	27 - 54	1.0-2.75	120-277	•	•					•	•				F-Can chassis mount/5	90

.....
Indoor linear
LED drivers
.....

Linear Drivers – Programmable

Catalog	Max Output Power (W)	Output Voltage (V)	Output Current (Amps)	Input Volts	UL/ CSA Class 2	Dimming					Features					Dim./ Wiring Dia.	Max Tcase (°C)
						0-10V	TE	LE	Step Dim	DALI	AOC	MTP	CLO	Fan	Others		
XI075C200V054XPT1	75	27 - 54	0.7 - 2.0	120 - 277	•	•					•	•	•			T-425/11	75
XI075C200V054YPT1	75	27 - 54	0.7 - 2.0	120 - 277	•						•	•	•			T-425/12	75

Linear Driver Dimensions

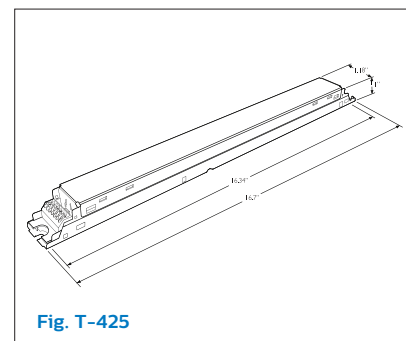
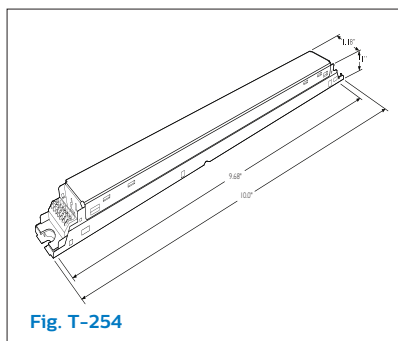
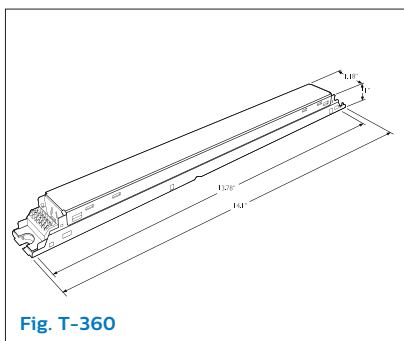

Linear Driver Wiring Diagrams

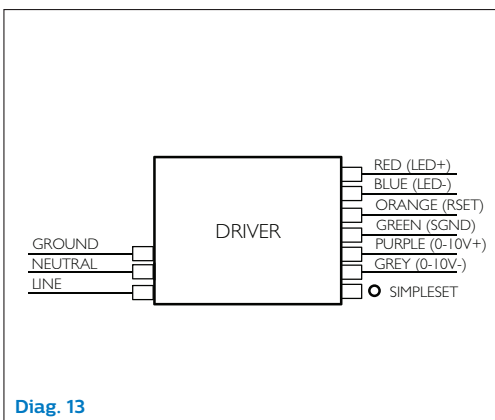
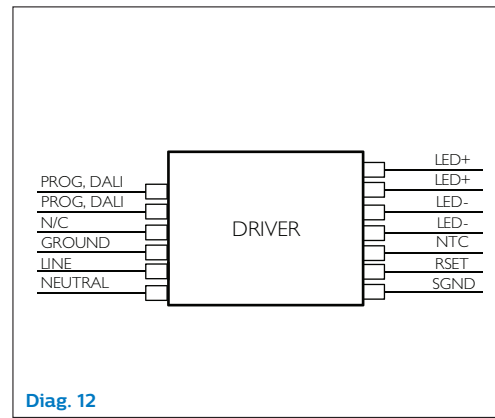
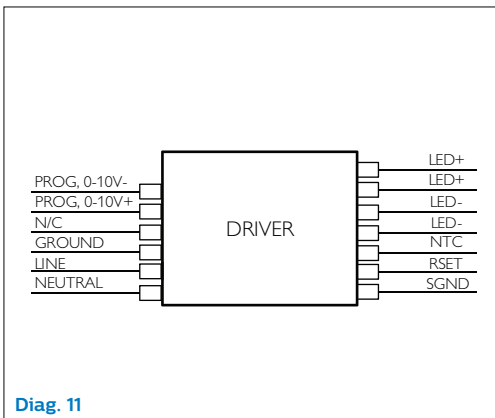
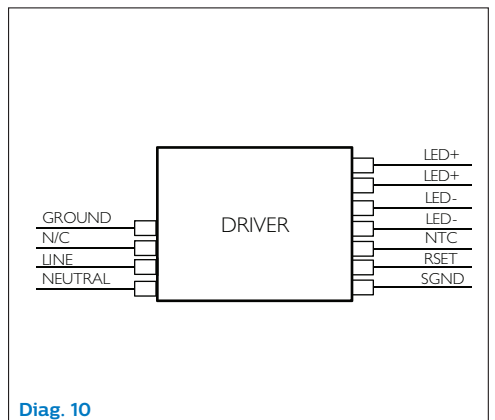
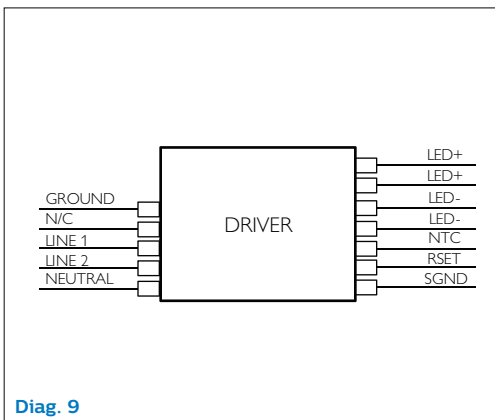
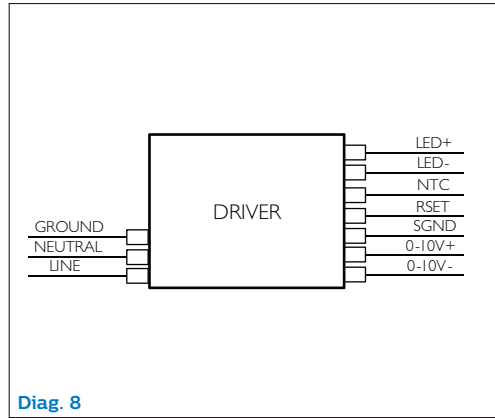
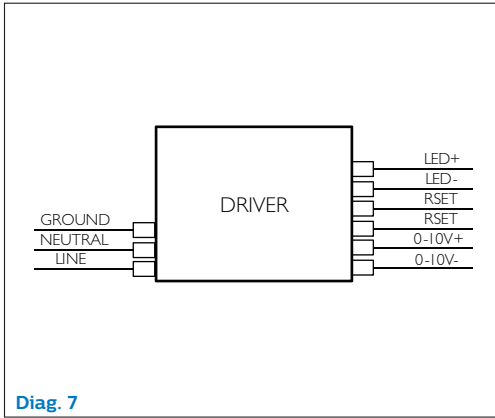

Accessories

Surge Protection Devices

Rapidly increasing acceptance of LED-based light sources for outdoor applications brings with it new challenges on system durability. In order to ensure the lifetime of the LED solution, it is vital to protect the light engine against surges on the mains line. Even the most robust LED drivers offer a limited level of surge protection, not enough to defend against high surges, e.g., (indirect) lightning strikes. Road lighting and parking lots are especially susceptible. Philips Surge Protection Devices offer a reliable solution for protecting all outdoor power supplies from excessive surge voltages.

Why not make an LED driver with built-in surge protection?

In theory it is possible to design a driver with sufficient spacings internally to survive a 10 kV surge voltage from lines to case (ground) without clamping the voltage so that hi-pot testing is not affected. This concept was implemented on some electronic HID control gear. However, in a typical LED system, the

LEDs are mounted to a heat sink, which is connected to earth ground for thermal reasons. A common mode surge voltage of 10 kV would break over the insulation between the LEDs and the heat sink in most installations, and, therefore, voltage clamping is required. The typical breakdown of the LEDs to the heat sink is in the order of 2 kV, so clamping below this level is necessary even if the driver is designed to handle the higher voltages. This is why a driver design that can handle 10 kV surges does not help the system pass 10 kV. The voltages must be clamped to a level that the LED-to-heat sink insulation can safely withstand to prevent LED failure. Also, not clamping the common mode surges would put a large burden on the wiring inside the fixture as everything would need to be designed to withstand 10 kV (wires, connectors, wire nuts, etc.). An external surge protection device provides the necessary clamping eliminating the need for high voltage surge protection within the driver and at the same time protects the LEDs from common voltage surges.



277V Surge Protection Device



The Philips 277V Surge Protection Device (SPD) is the ideal solution to the challenge of using outdoor LED lighting. The SPD clamps the voltage at the terminals of the luminaire, protecting the complete system against multiple nominal surges up to 10 kV / 5 kA. For maximum-level of protection, the SPD can withstand a single hit of 10 kV / 10 kA and also eliminates the need for all internal luminaire components – wires, connectors, wire nuts, etc. – to be designed to withstand 10 kV. Essential for LED systems installed in high-risk areas, the advantages of using the SPD are not limited only to LED systems. The product can be used in any new or existing lighting solution, regardless of technology.

General product characteristics

T ambient (°C): -40 to +70 °C, Tcase life (°C): +70 °C

Compliances and approvals

ANSI/UL 1449

Benefits

- Maximize the lifetime value of outdoor lighting applications
- No downtime due to calamities (storms, lightning strikes, etc.)
- Lower maintenance costs
- Easy to apply in new or existing installations
- Peace of mind on product performance

Features

- Resistant to peaks and surges of up to 10 kA / 10 kV
- Suitable for European Class I and Class II luminaires
- Xtreme standard: Long lifetime, robust protection against moisture, vibration and temperature extremes
- Can be used with all lighting technologies

277V Surge Protection Device

Type	Line Voltage (V)	Protection Level Up (L-N) (kV)	Protection Level Up (LN-earth) (kV)	Open Circuit Voltage (kV)	Nominal Surge Current I _N (kA)	Number of Surges, Nominal Current (Comm/Diff. mode)
Surge Protection Device 277V	100-277	≤ 1.6	≤ 2.5	10	1	100/100
Surge Protection Device 277V	100-277	≤ 1.6	≤ 2.5	10	3	100/100
Surge Protection Device 277V	100-277	≤ 1.6	≤ 2.5	10	5	45/35

Type	Maximum Surge Current I _{MAX} (kA)	Number of Surges, Maximum Current	Isolation Classification	Lifetime @ T _c life, 90% Survivals (hrs)	Suitable for Outdoor Use?
Surge Protection Device 277V	10	Comm. mode: 1 Diff. mode: 1	Suitable for Class I & Class II	100,000	Yes

Ordering and Packing Data

Type	Surge Protection Device 277V
12NC	9290 006 65202
EOC	8718291 161806 00
Minimum Order Quantity	10

Dimensions

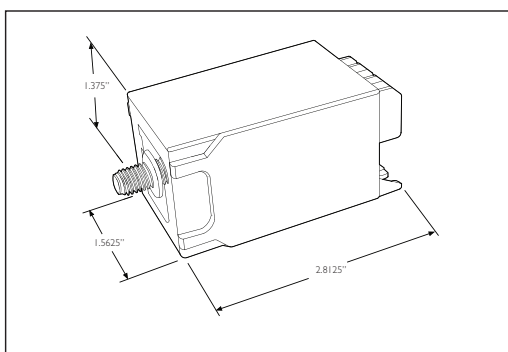

Mounting screw type: M8

Wiring Diagram

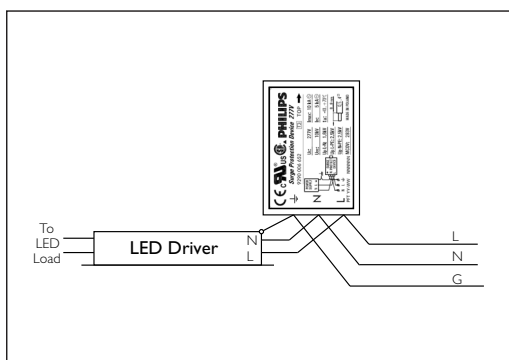

SP1 Surge Protection Device



Adapted to SSL outdoor lighting, the Philips SP1 Surge Protection Device provides single phase protection for line/neutral, line/ground and neutral/ground in accordance with IEEE C62.41 2002 C Low. The SP1's small size corresponds to the current design requirements for the new technology luminaires, like an LED light engine in outdoor lighting.

Catalog	SP1TP
Voltage Input	120V-277V (+/- 10%)
Frequency	50Hz-60Hz
Maximum Continuous RMS Voltage AC	320V
Maximum Energy	430 Joules
Maximum Peak Current	10kA (8/20 μ s standard wave)
Wiring	14 Gauges stranded wires, 105°C, 600V
Wire Connections	Black and white: 12mm skinned and thin plated Green: 12mm skinned with terminal malt
Mounting hole	5.5mm
Ambient Temperature (Operating)	-55°C to 85°C

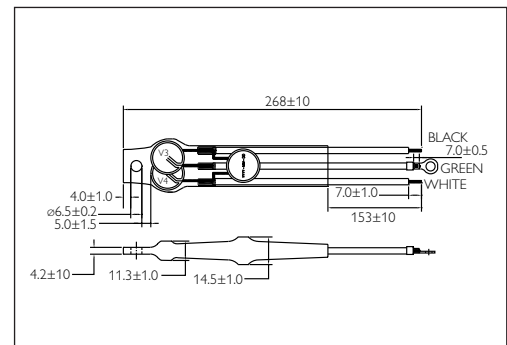
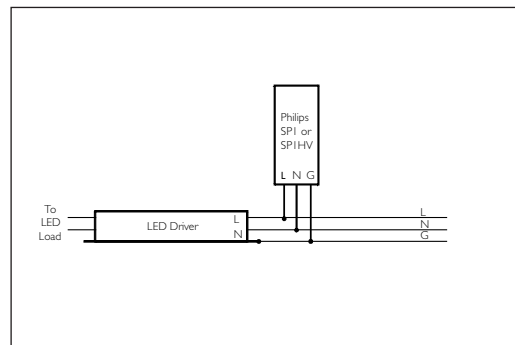

SP1HV Surge Protection Device



Adapted to SSL outdoor lighting, the Philips SP1HV Surge Protection Device provides single phase protection for line/neutral, line/ground and neutral/ground in accordance with IEEE C62.41 2002 C Low. The SP1HV's small size corresponds to the current design requirements for the new technology luminaires, like an LED light engine in outdoor lighting.

Catalog	SP1TP
Voltage Input	347V-480V (+/- 10%)
Frequency	50Hz-60Hz
Maximum Continuous RMS Voltage AC	520V
Maximum Clamping Voltage (8/20 μ s)	1500V
Maximum Energy	570 Joules
Maximum Peak Current	10kA (8/20 μ s standard wave)
Wiring	14 Gauges stranded wires, 105°C, 600V
Wire Connections	Black and white: 12mm skinned and thin plated Green: 12mm skinned with terminal malt Mounting hole: 6.5mm
Ambient Temperature (Operating)	-55°C to 85°C

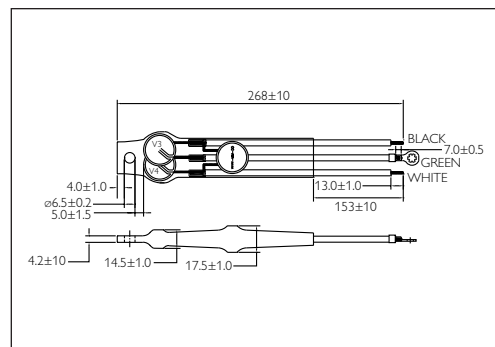
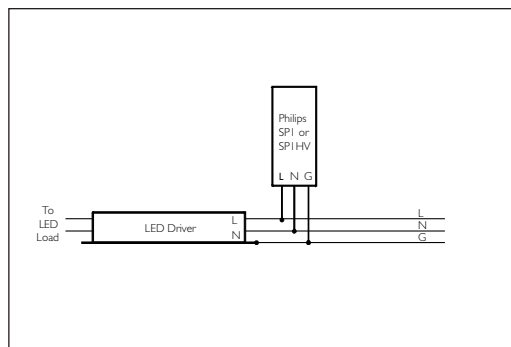

In order to protect the surrounding environment, this surge protection device must be enclosed in a luminaire that can contain flames and sparks, which may occur in case of malfunction, such as overvoltage power connection (ex:600V).

MultiOne Configurator



A single intuitive system that configures the different functions in multiple lighting solutions

Philips MultiOne Configurator is a single, intuitive system that configures different functions for multiple lighting solutions. Philips programmable drivers offer a full range of controls, enabling customizable luminaire design and performance. It is possible to control light output levels, preset dimming protocols and set system specifications in the factory and even in the completed installations. The MultiOne Configurator is a unique, intuitive tool that unlocks the full potential of all programmable drivers from Philips, ensuring driver performance matches the lighting solution needs.

Benefits

- One tool for all the Philips DALI products (see supported product list)
- Future-proof platform for new feature deployment
- Unique configuration and debugging tool
- Unprecedented flexibility before, during and after the product installation

Download software at www.philips.com/multione.

Dimensions

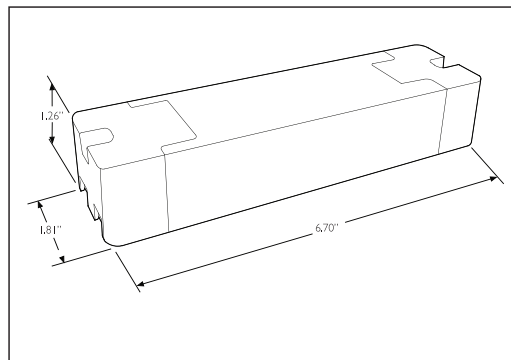

Disclaimer

The information in this guide is accurate at the time of writing. This guide is provided “as is” without expressed or implied warranty of any kind. Neither Philips nor its agents assume any liability for inaccuracies in this guide or losses incurred by use or misuse of the information in this guide.

Philips will not be liable for any indirect, special, incidental or consequential damages (including damages for loss of business, loss of profits or the like), whether based on breach of contract, tort (including negligence), product liability or otherwise, even if Philips or its representatives have been advised of the possibility of such damages.

Footnotes

1. Philips Advance Xitanium LED Drivers are designed and manufactured to engineering standards correlating to an average life expectancy of 50,000 hours of operation at maximum rated case temperature. Minimum 90% survivals based on MTBF modeling.
2. View limited warranty at http://www.usa.lighting.philips.com/connect/tools_literature/warranties.wpd for details and restrictions.
3. Restrictions on Hazardous Substances (RoHS) is a European directive (2002/95/EC) designed to limit the content of 6 substances [lead, mercury, cadmium, hexavalent chromium, polybrominated biphenyls (PBB), and polybrominated diphenyl ethers (PBDE)] in electrical and electronic products. For products used in North America compliance to RoHS is voluntary and self-certified.
4. Minimum 90% survivals based on MTBF modeling.



©2015 Koninklijke Philips N.V. All rights reserved. Philips reserves the right to make changes in specifications and/or to discontinue any product at any time without notice or obligation and will not be liable for any consequences resulting from the use of this publication.

PAd-1447QG 04/15 philips.com/leddrivers

Philips Lighting
North America Corporation
10275 W. Higgins Road
Rosemont IL 60018
Tel: 800-322-2086
Fax: 888-423-1882
Customer/Technical Service:
800-372-3331
OEM Support: 866-915-5886

Imported by: Philips Lighting,
A division of Philips Electronics Ltd.
281 Hillmount Rd,
Markham, ON, Canada L6C 2S3
Tel. 800-668-9008