

### Product description

The Philips Actilume Color is a DALI controller for color based lighting applications. The system consists of a color controller and a small lightweight sensor, designed for easy integration into luminaires. Also a programming kit is available, which consists of the Actilume Color Studio programming software and a RS232/DALI gateway. The Actilume Color controller can be operated with a remote control, or with either DALI (optimized for Philips MultiDim), DALI Color or DMX user interfaces. Complete DALI input interface support is expected at the beginning of 2009, because of the ongoing process of DALI Color standardization.

**Note:** Whenever there is referred to DALI (Color) in this document, this limitation must be considered.

The Actilume Color is a true Plug and Play solution for retail and hospitality, which can control up to 10 luminaires per controller. For larger systems, the Actilume Color controller can operate within a DALI, DALI Color or DMX (RDM) network, no commissioning is required for the DALI based lamp drivers connected to the Actilume Color Controller, which makes it easy to use and easy to install. An application brochure is available to help specify and apply the system in an optimal way.

### Features and benefits

- Philips Actilume Color is a flexible Stand-alone, DALI and DMX based lighting control system designed for dynamic and static color effects in small, medium-sized and large applications.
- Actilume Color is a flexible Plug & Play system; therefore no specific lighting control training is needed. Moreover, the system is supported with simple, dedicated application and installation sheets.
- In addition, the Actilume Color system can also be operated in larger and existing DALI or DMX backbone based networks.
- The simplest system is operated by an infrared remote control to recall 10 preprogrammed dynamic sequences and 10 static scenes.
- Actilume Color has open interfaces that allow proprietary user interfaces based on RC5 (like infrared remote controls), DMX or DALI (Color).
- Per Actilume Color controller, a maximum of 10 color luminaires can be controlled via the DALI R(ed), G(reen), and B(lue) output ports. In addition, 40 Actilume Colors can be connected to the DALI Ext port. This allows for a second level of Actilume Color controllers (repeater function). When the DALI Color standard is fully implemented it is also possible to connect other DALI Color based fixtures, like LEDs, to enlarge flexibility of the system.
- Easy to use programming of own dynamic color sequences with Actilume Color Studio software. The files of the programmed sequences and earlier chosen color palettes can be shared easily via internet/email.
- For larger systems within shops or public areas, it is possible to commission the Actilume Color controllers within an existing network. This also allows creating groups.
- Large building facades can be lit by using a MultiDim control to synchronize up to 60 Actilume Color controllers (or 600 RGB fixtures). Furthermore, the MultiDim controller can provide a scheduler function and other sensors.

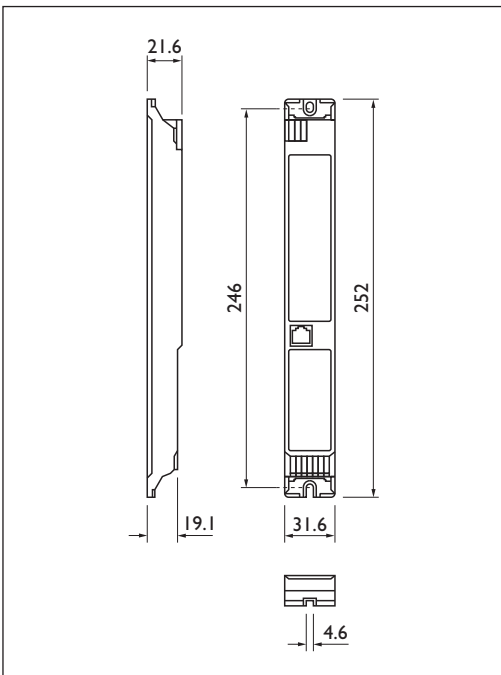

Dimensions in mm



**Applications**

- The Actilume Color system has been designed for all indoor applications within retail, hospitality, and public spaces, especially to attract people and to surprise them.
- It can be used for both dynamic sequences from very short to very slow (24 hr cycle), and static colors that are selected to support e.g. seasonal fashion, merchandize change, or a specific atmosphere in a bar or restaurant.
- It offers max. 16 preprogrammed sequences corresponding with seasons (Christmas, autumn) and daily situations (nature, sun set).

**Plug & Play control regimes**

- Simple systems with one Actilume Color controller are typically operated by MultiDim push button controls or remote control. The lamp drivers are directly connected to the Red, Green, and Blue outputs without any commissioning.
- LED drivers equipped with DALI Color can easily be connected to the Actilume Color Controller and can fully be integrated in the pre-programmed scenes or dynamic sequences.
- Larger systems with all luminaires providing the same color can be realized by connecting up to 40 Actilume Color Controllers (to the DALI-ext port) on one "master" Actilume Color controller; which is operated by a MultiDim push button or a remote control.

**Philips quality**

This applies optimum quality with respect to:

- System supplier  
As a manufacturer of lamps, electronic control gear and lighting control equipment, Philips ensures that, from the earliest development stage, optimum performance is maintained.
- International standards  
Philips Lighting Control equipment complies with all relevant international rules and regulations.

**Advanced color selection remote control IRT1670/00**

This remote control can be used for selecting pre-programmed color sequences and static colors. Already programmed dynamic sequences can be played faster (in half of the time), or slower (factor 3 or 6 slower). Static colors can be selected in hue and dim level and stored into the controller. Batteries are included.



*IRT1670/00 Remote Control*

**Actilume Color Programming Kit LCK1670/00 or LCK1671/00**

Consists of:

**Actilume Color Studio**

Actilume Color Studio is intuitive software for programming sequences into the Actilume Color controller. It allows direct preview, light plan overview, and grouping.

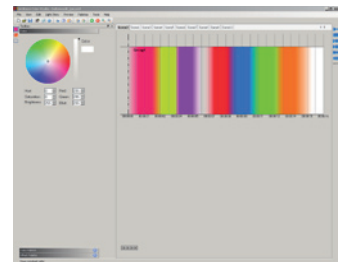

*Actilume Color Studio*

**RS232-DALI gateway**

The RS232-DALI gateway translates all communication between the personal computer and the DALI network.

The connection between PC and the DALI network is only necessary when the sequences are uploaded into the Actilume Color Controller. Two versions are available: 230V (LCK1670/00) and 24V (LCK1671/00).



*RS232-DALI gateway*

**RS232 Cable**

The RS232 cable connects a PC via the serial port to the RS232-DALI gateway

**Power cable (only LCK1670/00)**

**Compliances and approvals**

RFI<30 MHz	EN 55015
RFI>30 MHz	EN 55022 A
Immunity	EN 61547
Safety	EN 61347-1
	EN 61374-2-11 (SELV Equivalent)
	NEMA 410
	UL935
Quality standard	ISO 9001
Environmental standard	ISO 14001
Approval marks	ENEC:
	72/23/EEC (low voltage)
	89/336/EEC (electromagnetic compatibility)
	CSA
	UL-recognized (UL1310 for class II power supplies)
CE marking	

**Technical data**

**Technical data for installation**

Mains operation	Rated mains voltage 120-277 V
With tolerances for safety	+/- 10% 100-300 V
Mains frequency	50/60 Hz
Output power (system)	
R output	Maximum 10 DALI loads (20 mA)
G output	Maximum 10 DALI loads (20 mA)
B output	Maximum 10 DALI loads (20 mA)
Ext output	Maximum 40 DALI loads (80 mA)
DMX	64 mA
Sensor	5 mA

**Technical data for design and mounting in fixtures**

Operating conditions	
Controller and sensor	
Ambient temperature	+5 ... 50 °C
Rel. humidity operating	20% ... 85%, no condensation
Tcase	75 °C
Storage Conditions	-25 ... +70 °C
Rel. humidity storage	10% ... 95%
Lifetime	10% failure rate at 50k hrs with Tcase of 75 °C

**DMX operation**

Operating temperature	+5 ... 55°C
Protocol standards	ANSI I.11-2004 (USITT DMX512-A)

**ANSI I.20-2006 (RDM)**

Connector	8-position modular connector (RJ45)
-----------	-------------------------------------

**Transient/Burst Immunity and Surge**

	IEC 61000-4-4/5, level 2 on IO: 0.5kV
	UL840: over voltage category II (<50 V): 0.5 kV

**Network requirements**

	According to EIA-485-A specification
--	--------------------------------------

**Controller unit LLC1670/00**

In MultiDim operation and based on the pre-programmed colors, Actilume Color calculates the different dim levels for the Red, Green and Blue lamps, and the fading (dim levels) in between two color points. On the extended output, additional Actilume colors can be operated within the same sequences or scenes. Moreover, from the beginning of 2009, this output can also be used to connect additional DALI Color devices to create larger set-ups. In DMX operation, the real time DMX commands are directly translated into DALI commands on the output side.

**Actilume Color interfaces**

4x DALI current limited outputs	DALI-R: 10 DALI loads max
	DALI-G: 10 DALI loads max
	DALI-B: 10 DALI loads max
	DALI-EXT: 40 DALI loads max (mentioned as group RGBE_DA)

1x Actilume Multi-Sensor input, called SENSOR

1x RS-485 connection, based on DMX (RDM)

The controller only supports the RDM address setting. The RDM requires bidirectional RS-485 (half duplex) and a factory programmed device unique ID.

Transmission load	32 devices, with terminators
Transmission level range	0 ≤V≤+6 wrt common
Transmission frequency	250 kBit/s ± 2%
Reception level range	+12/-7 wrt common
Reception frequency	250 kBit/s ± 2.5%

Turn around time of DMX transceiver

176 µs after transmission of the last stop bits. When a DMX-RDM controller expects a response, the device must place its transmitter in high impedance state within 88 µs after transmission of the last stop-bit (of the last transmitted byte). Time between slots (data-bytes) may not exceed 76 µs.

1x DALI passive input, (DALI GP)

(Full DALI (Color) implementation expected in the beginning of 2009)

Transmit:	
Short circuit current	Max 250 mA
High-level range	11.5 ... 20.5 V
Low-level range	-4.5 ... 4.5 V
Rise/fall time	10 ... 50 µs
Transmission frequency	1200 Hz +/- 5%

Receive:

High-level range	9.5 ... 300 V
Low-level range	-6.5 ... 6.5 V
Rise/fall time	10 ... 50 ms (mains), 0 ... 100 µs (DALI)
Reception frequency	50/60 Hz (mains), 1200 Hz +/- 10% (DALI)

1x Universal mains input

**User interfaces**

Remote control

IRT1670/00 needs to be pointed to the sensor (IRR1651/00 or IRR1654) for starting dynamic sequences or static scenes. Broadcast commands will start pre-programmed sequences/static colors

Philips MultiDim

DALI COLOR (209) based controls (expected for 2009)

DALI Color commands will activate Actilume Color and all other (Lamp/LED) drivers based on DALI Color

Glow wire test  
Safety, basic insulation  
Material

850 °C / 5 s  
< 2000V  
Polycarbonate + ABS Bay blend  
KU-2 1514  
UL94V-0  
Dark gray

Housing color

Mounting

The minimum distance between the fixation holes is 236 mm.

**Connections for DALI and mains**

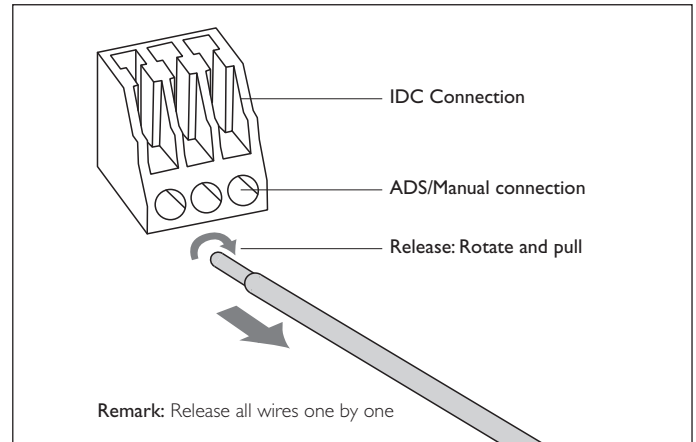

IDC Connection

0.5 mm – 0.75 mm<sup>2</sup> \*  
ADS or manual push wire insert 0.5 mm – 1.0 mm<sup>2</sup>  
\* Stranded wire  
8.0 – 9.0 mm

Strip length

**Master Luminaire**

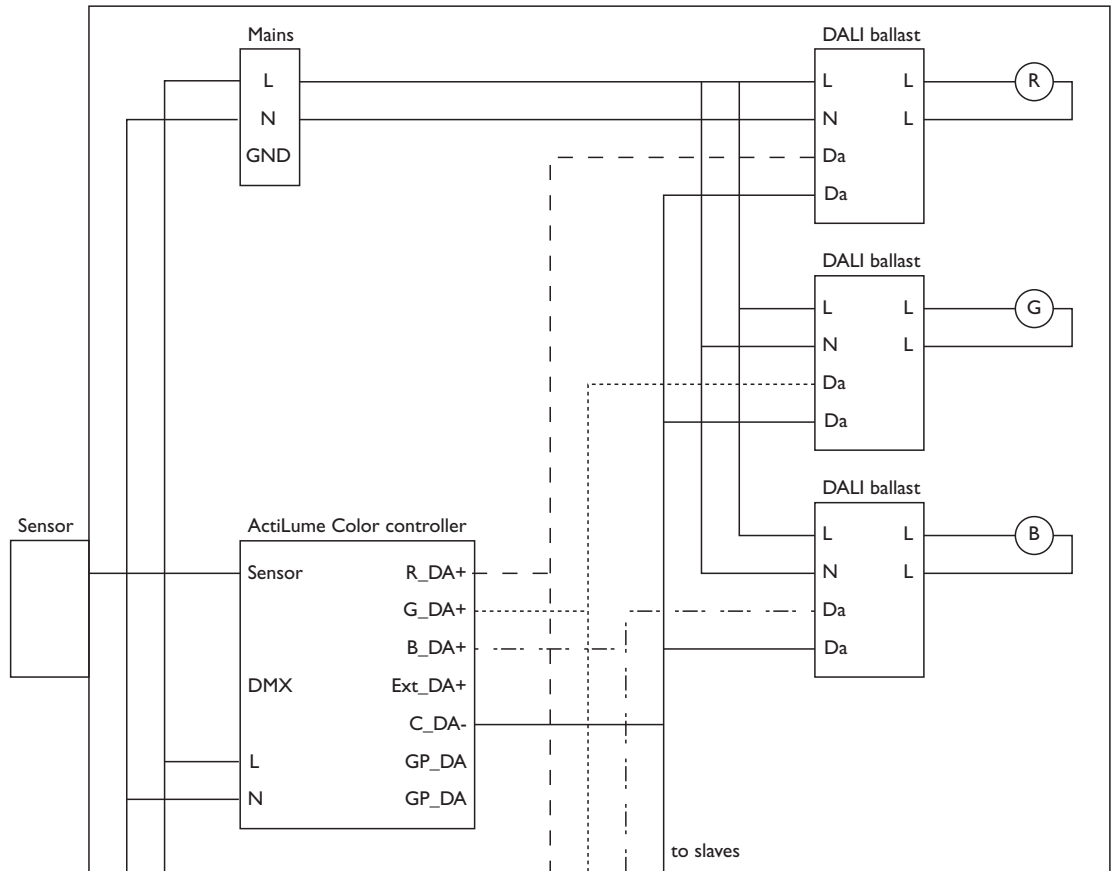

Wiring scheme

Sensor IRR1651/00 without cap	
Sensor IRR1654/00 with cap	
Sensor IRR8125/10 invisible	
Connection	RJ-10 4-Pole 100 cm cable
Housing (casing)	
Material	Polycarbonate UL94 V-0
Glow wire test	950 °C / 5 s
Safety, basic insulation	< 2000 V
Infrared receiver	RC5 signal
	Minimum range 20 m <sup>2</sup>
Cap material IRR1654	Polycarbonate, RAL7035

**Packing data**

Type	Box dimensions (mm)	Qty	Material	Weight (Kg) net
Controller LLC1670/00	259 x 201 x 110	24	card board	2.78
Remote control IRT1670/00	200 x 180 x 125	18	card board	1.90
IR Sensor IRR1651/00	n/a			0.03
IR Sensor IRR1654/00	230 x 177 x 160	24	card board	0.03
IR Sensor IRR8125/10	n/a	1	plastic	0.03
Programming kit 230V LCK1670/00	160 x 200 x 135	1	card board	0.70
Programming kit 24V LCK1671/00	160 x 200 x 135	1	card board	0.64

**Ordering Data**

Type	MOQ	Ordering number	EAN code level 1	EAN code level 3	EOC
Controller LLC1670/00	24	9137 006 34172	8711500 915719	8711500 915726	915719 30
Remote control IRT1670/00	18	9137 006 38891	8711500 915832	8711500 915849	915832 30
IR Sensor IRR1651/00	48	9137 003 34172	8711559 730639	8711559 730639	730639 99
IR Sensor IRR1654/00	24	9137 006 38991	8711500 915856	8711500 915863	915856 30
IR Sensor IRR8125/10	1	9137 003 27603	8711559 731315	8711559 731322	731315 99
Programming kit 230V LCK1670/00	1	9137 006 41566	x	8727900 805239	805246 00
Programming kit 24V LCK1671/00	1	9137 006 41666	x	8727900 805246	805239 00

3222 636 35090  
09/2008  
Data subject to change

[www.philips.com/lightingcontrols](http://www.philips.com/lightingcontrols)

