



PHILIPS

LED Modules

Design-in Guide

Fortimo DLM Flex



The economical choice for commercial downlight applications

Fortimo LED DLM Flex Module Design-in Guide

Contents

Introduction to this guide	3	Norms and standards	23
Determine which documents contain what information	3	Safety	23
Warnings and instructions	4	Safety Related Electronic Circuit	23
Introduction to the Philips Fortimo LED Downlight Module (DLM) Flex	5	Performance	23
Fortimo LED DLM Flex Module	5	Electromagnetic compatibility (tested with Fortimo LED DLM Flex Module and Philips Advance Xitanium LED Driver)	23
Applications	5	Environmental	23
Fortimo LED DLM Flex Module	5	ElectroStatic Discharge (ESD)	23
Philips Advance Xitanium LED Drivers for Fortimo LED DLM Flex Module	6	Approval	24
Emergency Application	6	UV and other hazards	24
Dimensions	6	IEC recommendations	25
Optical design-in	7	Photobiological safety aspects	25
Fortimo LED downlight modules address the issue of binning	7	Chemical compatibility	26
Color consistency (SDCM)	7	Humidity	28
Starting characteristics	7	Exposure to direct sunlight	28
Lumen maintenance	7	Vibration and shocks	28
Light distribution	7	IP codes, dust and moisture protection	28
Secondary optics	8	Philips Fortimo LED Flex Module systems are to be used for indoor applications	28
Mechanical design-in	9	End-of-life behavior	29
Mechanical fixation	9	Fortimo LED DLM Flex Module system disposal	29
Thermal design-in	10	Contact details	30
Optimum performance	10	Philips	30
How to measure the critical temperature point Tc	11	Partners for cooling solutions	30
Luminaire design using Safety Related Electronic Circuit	11	Partners for reflector solutions	30
Thermal Interface Material (TIM)	11	Partners for thermal interface materials	30
Electrical and thermal analogy	12	Disclaimer	31
Thermal model	13		
Passive cooling	13		
Electrical design-in	15		
Wiring	15		
Effect of choosing a different current value	17		
Set the output current via Rset	18		
Rset2	19		
XI095C275V054DNF1 Driver Rset Table	20		
Philips Advance Xitanium Driver operating window	21		
To select an appropriate driver	21		
Possible drivers at nominal conditions	22		

Introduction to this guide



Figure 1. Fortimo LED DLM Flex Module

Thank you for choosing the Philips Fortimo LED Downlight Modules. In this guide you will find all the information you require to design a luminaire based on these modules. As LED technology is continuously improving, we advise you to visit our website, www.philips.com/ledmodulesna, for the latest details.

More information or support

If you require any further information or support please consult your local Philips office. The Philips design-in team is also available to support you, and you can contact them via your local Philips representative.

Determine which documents contain what information

In order to provide information in the best possible way, Philips' philosophy on product documentation is the following.

- Datasheet contains the module specification, product family information and system combinations (compatible Philips drivers) and
- Design-in Guide describes how to design-in the products.

All these documents can be found on the download page of the OEM website www.philips.com/ledmodulesna. If you require any further information or support please consult your local Philips office.

Warnings and instructions



Warnings

- The Philips Fortimo LED DLM Flex Modules must be operated with UL Class 2 drivers!
- Avoid touching the light emitting surface!

Safety warnings and installation instructions

To be taken into account during design-in and manufacturing.

Design-in phase

- Do not apply mains power to the module (Philips Fortimo LED DLM Flex Module) directly.
- Connect the modules and drivers before switching on mains.
- Provide adequate environmental protection.

Manufacturing phase

- Do not use products if the LEDs are dislodged or if the housing is broken.
- In case the PCB gets loose from the housing during handling, the PCB can be remounted, when there is no damage on PCB and housing. Avoid touching the LEDs.
- Do not use the DLM Flex Module if it is dropped or damaged in any way.
- Connect the modules and drivers before switching on mains.
- Do not frequently poke in and release wires into the connector

Installation and service for luminaires incorporating the Fortimo LED DLM Flex Module system

- Do not service the luminaire when the mains voltage is connected; this includes connecting or disconnecting the Fortimo LED DLM Flex Module from the driver.

Philips design-in support is available; please contact your Philips sales representative.

Introduction to the Philips Fortimo LED Downlight Module (DLM) Flex

Fortimo LED DLM Flex Module

Fortimo LED DLM Flex is the new economic choice in the Fortimo LED Downlight Module (DLM) product family targeted for commercial downlighting applications. The Fortimo LED DLM Flex Module has the same mechanical footprint as the previous generations of Fortimo LED DLM. The same familiar Fortimo LED DLM footprint ensures fixture updates without enduring the hassles of retooling or re-designing fixtures or changing manufacturing processes.

Applications

As the name suggests, the Philips Fortimo LED Downlight Module (DLM) Flex is designed to be integrated into downlight luminaires for indoor use. OEMs may explore other applications and luminaires as long as there is no design conflict and compliance is ensured with luminaire standards, such as UL 1598.

Can the module be used in outdoor luminaires?

Neither the Fortimo LED Module nor the driver has an IP classification. If these products are used in luminaires for outdoor applications, it is up to the OEM to ensure proper IP protection and approbation of the luminaire. Please consult us if you wish to deviate from the design rules described in this guide.

Fortimo LED DLM Flex Module

All Fortimo LED DLM Flex Modules are built-in versions for integration into luminaires. The modules have interfaces for:

- Cabling between LED module, driver and luminaire
- Secondary optics via mounting options in the LED module housing and reflector rim
- Heat sink design via heat spreader.

Naming of Fortimo LED DLM Flex Modules

The names of the modules are defined as follows. The Fortimo LED DLM Flex 2000/840 Gen 1 is used here as an example.

- Fortimo : Our brand name for efficient, clear and reliable lighting
- DLM : Downlight module
- Flex : The new DLM modules offer flexibility in terms of design and usage
- 2000 : 2000 lumens
- /840 : For a color rendering index of 80; 40 stands for a CCT of 4000 K
- Gen 1 : Generation of product



Figure 2. Philips Bodine BSL17C-C2 Emergency LED Driver

Philips Advance Xitanium LED Drivers for Fortimo LED DLM Flex Modules

These highly efficient LED drivers are designed for the Fortimo LED Modules. These are available as SmartMate form factor for downlighting with flexible current setting by Rset, dimmable (0-10V). Compatible driver and system level data can be found in Fortimo LED DLM Flex Module datasheets.

Emergency Application

All commercial and government buildings in the U.S. require emergency lighting in order to meet the Life Safety Code NFPA 101. Philips Emergency Lighting offers the BSL17C-C2 Emergency LED Driver, specifically designed for the Fortimo LED DLM Flex Module. When AC power is lost, the BSL17C-C2 takes over operation of the LED module for 90 minutes to help comply with emergency code requirements. The BSL17C-C2 is Class 2, UL Component Recognized and CSA Certified. Please check the emergency driver specification sheet for the latest wiring diagram.

For more information, please visit www.bodine.com/products/specs/bsl17cc2.html. Emergency product training videos can be found at www.youtube.com/user/PhilipsBodine.

Dimensions (mm)

(Based on dimensional data, typically ± 0.2 mm.)

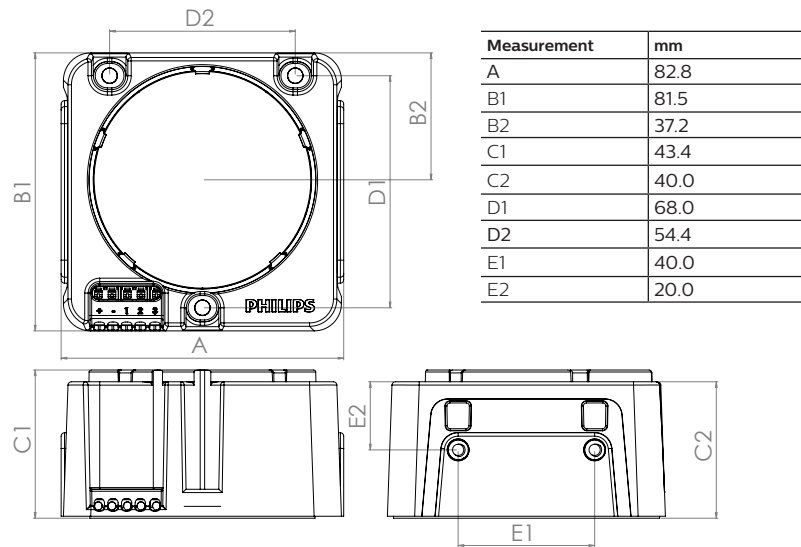

Figure 3A. Fortimo LED DLM Flex Module dimensions

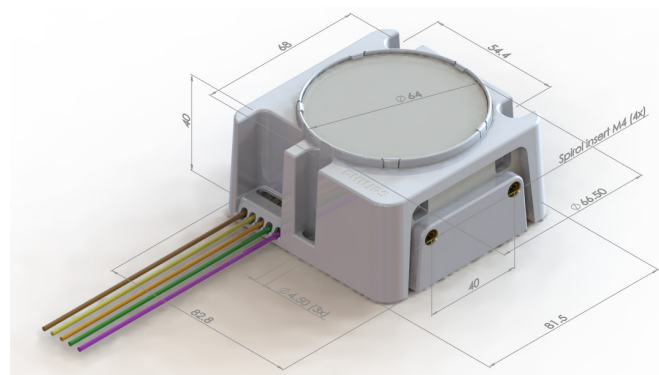

Figure 3B. Fortimo LED DLM Flex Module dimensions

Optical design-in

Fortimo LED downlight modules address the issue of binning

High-quality LED light is achieved by mixing the light of various LEDs. High quality white light is characterized by a good color consistency and a color rendering of >80, popular CCTs in general lighting applications of 2700K, 3000K, 3500K and 4000K. The mixing chamber ensures perfectly mixed light, resulting in excellent uniformity, low glare and good color consistency. The function of the diffuser is to shape the light distribution. The popular optical interface gives the freedom to design your own secondary optics. The LED module integrates easy mounting options for secondary optics. The overall dimensions of the LED module are optimized for lumen packages varying from 1100 to 5000 lumens.

Color consistency (SDCM)

The current specification of the Fortimo Modules for color consistency is 3 SDCM. SDCM stands for Standard Deviation of Color Matching, and the value 3 refers to the size of an ellipse around the black body locus. Staying within this ellipse results in a consistency of light whereby there is no perceivable difference from one luminaire to another. Details can be found in the product datasheet.

Starting characteristics

The Fortimo Modules can be switched on in milliseconds, which is a general characteristic of LEDs.

Lumen maintenance

L70B50 @ 50000 hours

The quality of the DLM Flex Module portfolio is backed by the Philips' claim of B50L70 @ 50,000 hours. This means that at 50,000 hours of operation at least 50% of the LEDs' population will emit at least 70% of its original amount of lumens.

This is contrary to conventional light sources, where some time after Service Life Hours the conventional light source emits no light at all.

In this section the example graphs show the estimated lumen depreciation curves for different percentage of the population and at nominal Tc temperatures (refer to figure 5). The actual data for the Fortimo LED DLM Modules can be found in the associated datasheet at www.philips.com/ledmodulesna.

Average rated life is based on engineering data testing and probability analysis. The Fortimo LED DLM Flex Modules are specified to reach L70B50 for the nominal specifications.

Lumen maintenance for B10 and B50

The example graph is showing the lumen maintenance (% of initial lumen over time) for B50 (50% of the population) and B10 (90% of the population).

Please look up the actual lumen maintenance graph in the associated datasheet of the module you are using at www.philips.com/ledmodulesna.

Light distribution

The Fortimo LED DLM Flex Module generates a near Lambertian beam shape (see Figure 4). The secondary optics design should not cover the exit aperture. The IES (or .ldt) files are available via the website www.philips.com/ledmodulesna.

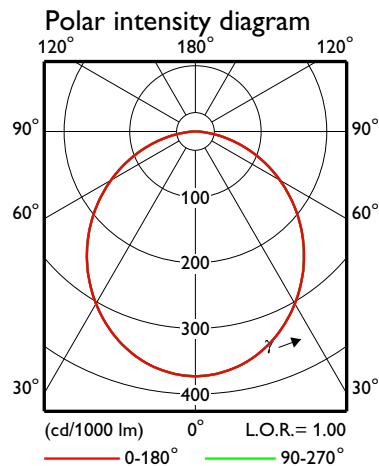

Figure 4. Light distribution diagram

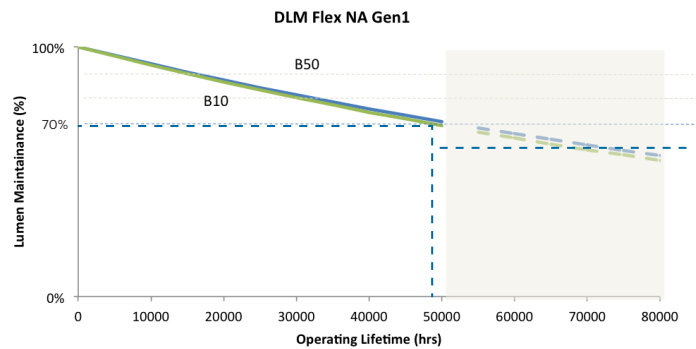

Figure 5. Example lumen maintenance as a function of operating hours for B10 and B50 at Tc nominal

Secondary optics

The Fortimo LED DLM Flex Module generates a near Lambertian beam shape, the polar intensity diagrams for each module are given in the datasheets. This is a pragmatic starting point for secondary optic design. The secondary optic design should not cover the exit aperture. Ray-set files are available via the website www.philips.com/ledmodulesna.

On the top of the Fortimo LED DLM Flex Module there are mounting options (rim of diffuser, three mounting holes and four side mounting holes) for positioning secondary optics.

Companies supplying reflectors for secondary optics

Secondary optics is not part of the Fortimo LED DLM Flex Module system offering. This can be an added value area for OEMs. We provide a list of complementary reflector partners that have developed reflectors around the Fortimo LED DLM Flex Module. The table below gives a list of complementary partners offering compatible reflectors for Fortimo LED DLM Flex Modules.

The following are examples of reflector suppliers that have products available to be used with the Fortimo LED DLM Flex Module system. Philips gives no warranties regarding these products and assumes no legal liability or responsibility for any loss or damage resulting from the use of the information given here.

Complementary Reflector Partner		Status
Alux Luxar	www.alux-luxar.de	Released
Jordan	www.jordan-reflektoren.de	Released
NATA	www.nata.cn	Released
ACL	www.reflektor.de	Released
Almeco	www.almecogroup.com	Released
Widegerm	www.widegerm.com.hk	Released

Table 1. Secondary Optics

Mechanical design-in

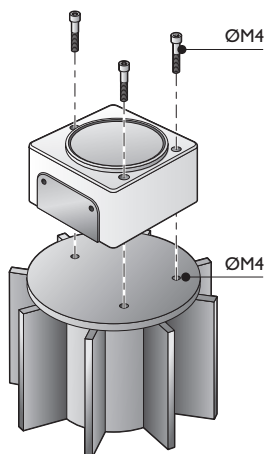

Figure 6. Screw installation

Mechanical fixation

Mounting to heatsink

Please note that due to the thickness of the PCB, mounting of the light engine from the back is not possible; only fixation through the module is applicable. Figure 6 on the left shows the correct mounting procedure. It is suggested to use a M4 or #8 socket head cap machine screw or #6 pan head machine screw from the top of the module to heat sink. The recommended torque on the M4 screws is **0.5Nm**.

Advice: Do not screw into the top of the module.

Side mounting

The housing has M4 threaded inserts on the side that can be used to fix reflectors. M4 machine screws can be used for side mounting. The maximum load per screw is 5N (500gr) and the total maximum load applied on the side fixation holes is 20N (2000gr). The maximum applied torque is 1.5Nm per screw. 2D or 3D CAD drawings are available at www.philips.com/ledmodulesna.



Warnings

- The recommended torque mounting module to heatsink is 0.5Nm, only 1/10 of torque vs. DLM Gen 4!

Thermal design-in

The critical thermal management points for the LED module are set out in this chapter in order to facilitate the design-in of Fortimo LED DLM Flex Modules. If these thermal points are taken into account, this will help to ensure optimum performance and lifetime of the LED system.

Optimum performance

To ensure optimum performance, the Fortimo LED DLM Flex Module system must operate within specified temperature limits.

Test requirements

Measurements, e.g., of temperature, luminous flux and power, are reliable once the luminaire is thermally stable, which may take between 0.5 and 2 hours. The time depends on the thermal capacity of the luminaire. Measurements must be performed using thermocouples that are firmly glued to the surface (and not, for example, secured with adhesive tape).

Critical measurement points

Because LEDs are temperature sensitive, LED modules require a different approach with respect to the maximum permissible component temperature. This is different than most other types of light sources.

For LEDs the junction temperature is the critical factor for operation. Since there is a direct relation between the case temperature and the LED junction temperature, it is sufficient to measure the aluminum casing of the LED module at its critical point. The critical point is on the rear surface of the LED module, as shown in Figure 7 on the left. If the case temperature (T_c) at the critical measurement point exceeds the recommended maximum temperature, the performance of the LEDs will be adversely affected, for example in terms of light output, lifetime or lumen maintenance.

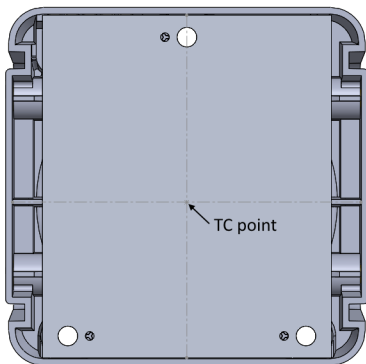

Figure 7. Temperature test point T_c



Warning: Case temperature

To ensure the performance of the Fortimo DLM system, a maximum T_c is defined on the rear surface of the LED module. At this case temperature the proper junction temperature of the LEDs is assured and the performance indicated (lifetime, light output, lumen maintenance, etc.) can be guaranteed.

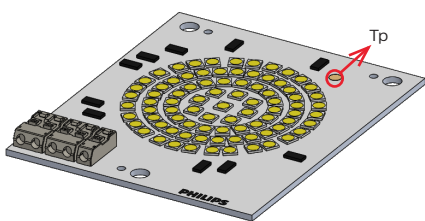

Figure 8. Tp temperature measurement point

How to measure the critical temperature point Tc

The Tc temperature can be measured by making a thin v-groove or a small drill hole in the heat sink to reach the bottom of the LED module. Be sure to measure the temperature of the bottom metal part of the module.

For the Fortimo LED DLM Flex Module, Tp as indicated in Figure 8 on the left, can also be used for easier access. The correlation between Tp and Tc is dependent on the heat sink design. The difference between Tp and Tc is around 1 to 2°C using the standard heat sinks from our complementary partners.

Luminaire design using Safety Related Electronic Circuit

The system of Fortimo LED DLM Flex Gen 1 with approved Philips Advance Xitanium Drivers mentioned in this document qualifies for UL Safety Related Electronic Circuit program as prescribed by UL 991 and CSA 22.2 0.8.

This program allows the Fortimo LED DLM Flex Gen 1 system to be installed as a replacement for the thermal protector as described in UL 1598 section 11.5 titled Thermal Protectors.

The OEM can use the thermal protection circuit when testing the luminaire for compliance to UL 1598 for temperature tests. The Fortimo LED DLM Flex Gen 1 system will ensure that the luminaire will stay below 90°C surface temperature.

Thermal Interface Material (TIM)

The function of a Thermal Interface Material (TIM) is to reduce thermal impedance between the LED module and the heat sink. The Thermal Interface Material replaces air, which is a thermal insulator, by filling the gaps with material that has better thermal conductivity. This is shown schematically in Figure 9 on the left. Philips recommends always using a Thermal Interface Material (TIM). The Fortimo LED DLM Flex Module is designed to be mounted with M4 screws. The advised applied torque is 0.5 Nm and should not exceed 1 Nm in order to avoid damage to the module.

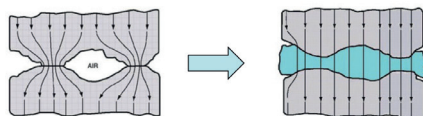

Figure 9. The working principle of Thermal Interface Material (TIM)

Advisted TIM	Recommended Torque
Paste	0.5 Nm
0.5mm soft pad material (Shore A < 40)	0.25 Nm

Table 2. Advisted TIM

In order to avoid air gaps underneath the LED board, it is not recommended to use hard thermal interface materials (Shore A > 80), like graphite.

In general:

- Thermal paste performs better than thermal pads.
- The lower the thermal impedance the better.
- The thinner the TIM the better, restriction is the surface flatness.

The following are suggestions for thermal interface material products that can be used with the Fortimo LED DLM Module system. Philips gives no warranties regarding these products and assumes no legal liability or responsibility for any loss or damage resulting from the use of the information given here.

Thermal Interface Partners

Laird Technologies	www.lairdtech.com
The Bergquist Company	www.bergquistcompany.com

Table 3. Thermal Interface Partners

Electrical and thermal analogy

Standard static thermal situations can be modeled using "thermal resistances." These resistances behave like electrical resistances. The analogy between electrical and thermal resistances is explained in Figure 10, "Electrical and thermal analogy." The electrical units are shown on the left, while the thermal equivalents are given on the right. With a known voltage difference at a certain current it is possible to calculate the electrical resistance using Ohm's law. The same applies for a thermal resistance. If the temperature difference and the thermal power are known, the thermal resistance can be calculated using the thermal Ohm's law.

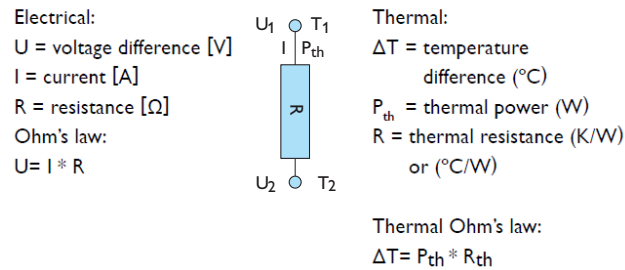

Figure 10. Electrical and thermal analogy

Thermal model

A thermal model that can be used to determine the required thermal performance of the cooling solution for the LED module is shown in the figure below.

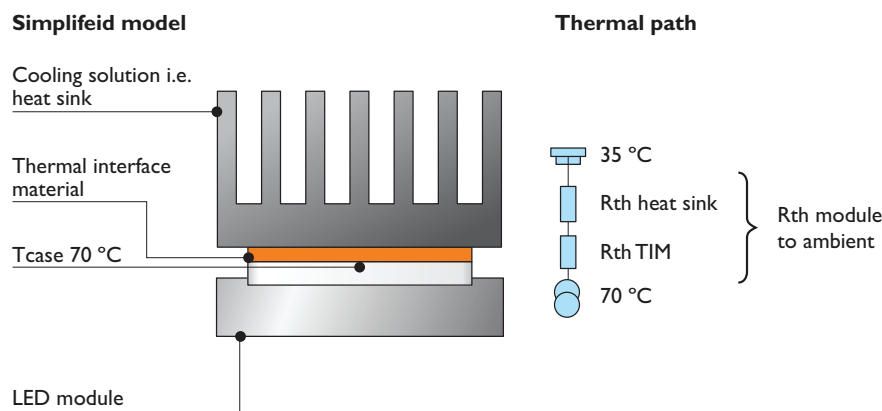

Figure 11. A simplified model of the thermal path from LED module to ambient



Warning:

The maximum temperature difference between T_c and $T_{ambient}$ should never exceed 50°C for the DLM Flex Module, otherwise it could lead to a reduction in the lifetime of the system.

Passive cooling

Passive cooling systems are based on the fact that hot air moves upward, thus creating airflow along the surfaces. This is called natural convection. There are many standard heat sinks available, but it is also possible to design your own heat sink. In general, a passive cooling solution requires a larger heat sink than an active cooling solution.

Some additional design guidelines for passive cooling include:

- Limit the number of thermal interfaces in the thermal path from module to ambient.
- Thick fins conduct heat better than thin fins.
- Large spacing between fins is better than small spacing between fins; air flow follows the path with least resistance.
- Make cooling surfaces more effective by using proper conductive materials, appropriate thickness and correct fin orientation.
- Thermal radiation plays a significant role anodized or powder-coated surfaces are preferable to blank surfaces.

Complementary thermal solution partners

Thermal solutions do not form part of the Fortimo LED DLM Flex Module system offering. This is an added-value area for OEMs, offering the possibility to differentiate. However, there are many thermal solution companies who have a standard portfolio of compatible heat sinks available, enabling quick and easy luminaire creation. The table below gives a list of complementary partners offering compatible cooling systems for Fortimo LED DLM Flex Modules. An up-to-date list can be found on our website: www.philips.com/ledmodulesna.

The following are examples of providers of cooling solutions that can be used with the Fortimo LED DLM Flex Module system. Philips makes no warranties regarding these products and assumes no legal liability or responsibility for any loss or damage resulting from the use of the information given here.

Complementary Heat Sink Partners	Heat Sink Type	Status
Sunon (www.sunon.com)	Active + passive	Released
AVC (www.avc.com.tw)	Active + passive	Released
MechaTronix (www.mechatronix-asia.com)	Active + passive	Released
Nuventix (www.nuventix.com)	Active + passive	Released
Wisefull (www.wisefull.com)	Active + passive	Released

Table 4. Complimentary Heat Sink Partners

Electrical design-in

Wiring

Connection to the mains supply/protective earth

The mains supply has to be connected to input terminal of the driver (Line and Neutral can be interchanged).

Connection to the module

There are five connectors available on the DLM Flex Module. These have been clearly marked as “+,” “-,” “1,” “2” and “3” to be connected with terminals “LED(+),” “LED(-),” “Rset2,” “SGND” and “NTC” on the LED driver.

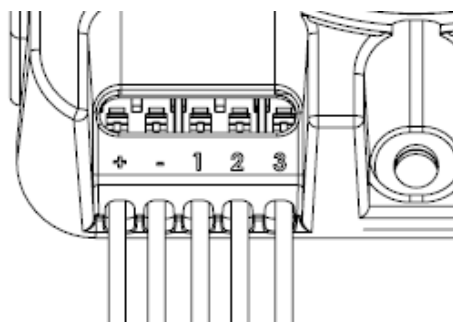

Figure 12. Connection to the module

Code	+	-	1	2	3
Function	LED (+)	LED (-)	Rset	SGND	NTC
Driver Connector Color	Brown	Yellow	Orange	Green	Violet

These can be used with simple push in wires in order to connect to the driver. The following are the specifications for the wires that can be used:

Specification Item	Value	Unit
Wire cross-section (Solid wire)	0.2 - 0.8	mm ²
	24 - 18	AWG
Wire cross-section (Stranded wire)	0.45 - 0.7	m
	22 - 20	AWG
Wire cross-section (Solid wire)	0.2 - 0.8	m

Tune the luminaire's flux (lm) and efficacy (lm/W)

The Fortimo LED DLM Flex Module specifications are provided under nominal conditions, like nominal flux at nominal current. If the Rset cable between LED module and LED driver (1 – orange) is connected, the driver automatically gives the nominal current to the LED module. The nominal currents can be found in the individual datasheets that under www.philips.com/ledmodulesna.

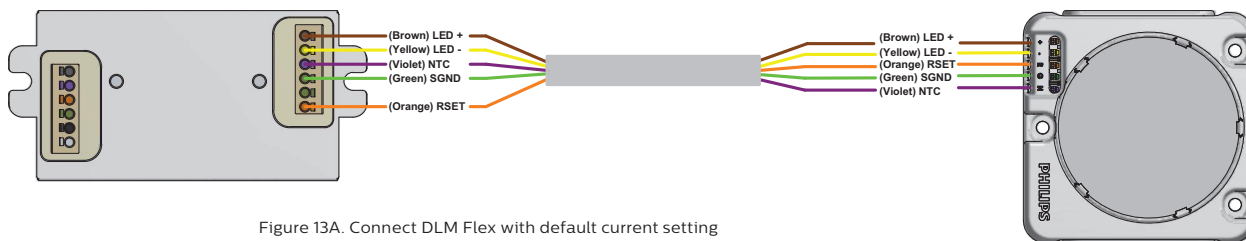

Figure 13A. Connect DLM Flex with default current setting

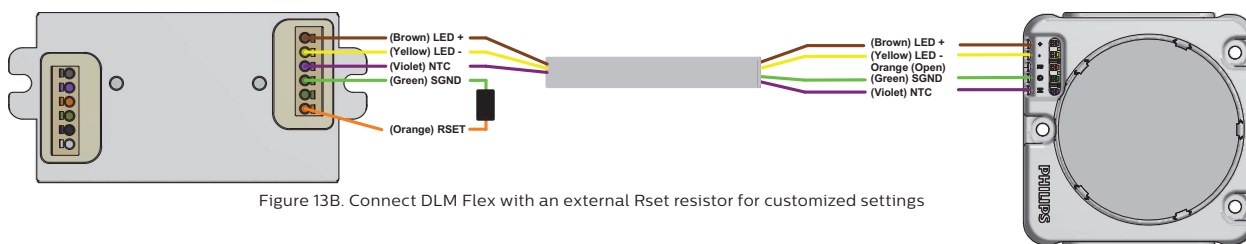

Figure 13B. Connect DLM Flex with an external Rset resistor for customized settings

It is possible to deviate from the nominal current setting to alter the performance of the product. By altering the current using Rset2 resistor on the driver, one can obtain different light outputs. See wiring diagram in Figure 13B. At the same time, the required forward voltage (Vf) also changes and the efficacy (lm/W) of the LED module changes. The following sections explain the impact and boundaries.

Effect of choosing a different current value

In case the customer chooses to set the current other than the nominal current, the lifetime and reliability of the Fortimo LED DLM Flex Module must be taken into account. The following current regions can be distinguished:

1. Current < nominal current* (mA)
 - a. Efficacy (lm/W) higher than nominal value lumen output (lm) lower than nominal value
 - b. Lifetime > 50,000 hours[†]
2. Current between nominal current and absolute maximum current** (mA). Your warranty may be affected in this case.
 - a. Efficacy (lm/W) lower than nominal value lumen output (lm) higher than nominal value
 - b. Lifetime may be < 50,000 hours[†]
3. Current > absolute maximum current: do not exceed the absolute maximum current as this can lead your DLM module to failure. No warranty applicable in this case.

[†] The rated average life is based on engineering data testing and probability analysis. The hours are at the L70B50 point.

* Nominal current at which performance and lifetime is specified

** Maximum current tested for safety

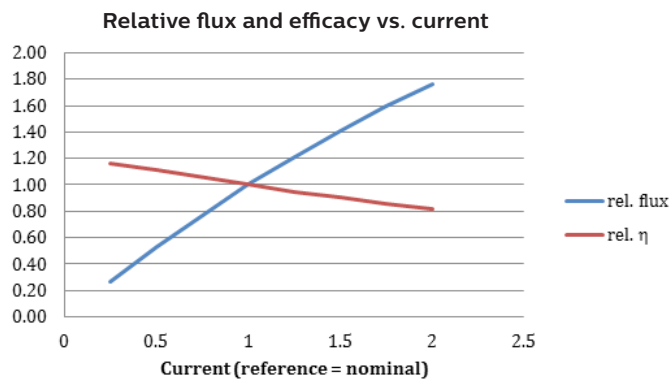

Figure 14. Example graph showing flux and efficacy as a function of current

Set the output current via Rset

By making use of a resistor component with a determined Ohmic value you can set the required current for your LED module. This component can be a leaded standard 1% tolerance resistor of, e.g., 0.125W or 0.25W, 50V. The Rset will not be part of the electrical chain driving the module. An example of a resistor placed into the drivers' output is shown in Figure 13B.

Two different Rset resistors are utilized in the Xitanium LED Driver portfolio:
Rset1 (older drivers)*; allows output current setting up to 700mA
Rset2; allows output current setting up to 2000mA

In all documentation, Rset may refer to either Rset1 or Rset2, depending on the driver type. Please check the driver datasheet for which Rset (1 and/or 2) the driver you use reads. You can find this at www.philips.com/ledmodulesna.

Rset1 and Rset2 use different pins on the driver. Rset2 values with the corresponding drive currents are shown in following tables. It is advised to select the nearest lower resistor value that is available to you, if the exact determined value is not at hand.

XI095C275V054DNF1 driver uses a different Rset table from Rset1 and Rset 2. Connecting XI095C275V054DNF1 with DLM Flex Rset and SGND terminals does not generate nominal current. Use an external Rset resistor to set XI095C275V054DNF1 at the desired current level. Rset information is in table 6.

**Please note that if you have a driver that supports both Rset1 and Rset2, choose Rset2. All future drivers will support Rset2.*

Material Description	12 NC	Resistance [Ω]	Type
Fortimo LED Rset2 NA 300mA	929000727713	560	Push in
Fortimo LED Rset2 NA 500mA	929000727813	1,200	Push in
Fortimo LED Rset2 NA 300mA	929000727713	560	Push in
Fortimo LED Rset2 NA 950mA	929000728013	3,090	Push in
Fortimo LED Rset2 NA 1200mA	929000728113	4,780	Push in
Fortimo LED Rset2 NA 1800mA	929000728213	15,000	Push in

Table 5. Rset accessories

The Fortimo LED DLM Flex specifications are provided under nominal conditions, like nominal current. It is, however, possible to deviate from this nominal current by using an external Rset resistor. Below is a list of Rset components that can be used based on design requirement.

Rset2

Rset2 [Ω]	Iset [mA]	Rset2 [Ω]	Iset [mA]	Rset2 [Ω]	Iset [mA]	Rset2 [Ω]	Iset [mA]	Rset2 [Ω]	Iset [mA]	Rset2 [Ω]	Iset [mA]
short	min.	255	171	665	335	1740	669	4530	1171	11800	1686
100	100	261	173	681	341	1780	679	4640	1185	12100	1698
102	101	267	175	698	347	1820	689	4750	1198	12400	1708
105	103	274	178	715	354	1870	701	4870	1212	12700	1719
107	104	280	181	732	361	1910	711	4910	1216	13000	1730
110	105	287	184	750	368	1960	724	5110	1239	13300	1739
113	107	294	187	768	374	2000	733	5230	1253	13700	1752
115	108	301	191	787	381	2050	745	5360	1267	14000	1761
118	110	309	194	806	387	2100	757	5490	1281	14300	1771
121	111	316	197	825	394	2160	770	5620	1295	14700	1783
124	113	324	201	845	400	2210	782	5760	1308	15000	1793
127	115	332	204	866	407	2320	806	5900	1322	15400	1802
130	116	340	207	887	414	2360	815	6040	1335	15800	1812
133	118	348	210	909	422	2370	817	6190	1349	16200	1822
137	119	357	214	931	429	2430	829	6340	1362	16500	1829
140	120	365	217	953	436	2490	841	6490	1375	16900	1838
143	122	374	221	976	444	2550	853	6650	1389	17400	1850
147	123	383	225	1000	452	2610	865	6810	1403	17800	1859
150	125	392	229	1020	459	2670	877	6980	1415	18200	1867
154	127	402	233	1050	469	2740	891	7150	1428	18700	1877
158	129	412	237	1070	475	2800	903	7320	1441	19100	1885
162	131	422	241	1100	485	2870	916	7500	1454	19600	1894
165	132	432	246	1130	494	2940	929	7680	1467	20000	1902
169	134	442	250	1150	500	3010	943	7870	1480	20500	1910
174	136	453	254	1180	509	3090	956	8060	1493	21000	1918
178	137	464	259	1210	518	3160	968	8250	1506	21600	1928
182	139	475	263	1240	527	3240	982	8450	1518	22100	1936
187	141	487	268	1270	536	3320	996	8660	1531	23200	1952
191	143	491	270	1300	545	3400	1009	8870	1544	23600	1959
196	145	511	278	1330	554	3480	1022	9090	1557	23700	1960
200	146	523	282	1370	565	3570	1037	9310	1569	24300	1968
205	148	536	287	1400	574	3650	1049	9530	1580	24900	1975
210	151	549	292	1430	582	3740	1062	9760	1592	25500	1982
216	153	562	297	1470	594	3830	1075	10000	1604	26100	1989
221	155	576	302	1500	602	3920	1088	10200	1614	26700	1996
232	161	590	307	1540	614	4020	1103	10500	1629	27000	2000
236	163	604	313	1580	626	4120	1117	10700	1639	open	default
237	164	619	318	1620	638	4220	1131	11000	1653		
243	167	634	323	1650	645	4320	1145	11300	1666		
249	169	649	329	1690	656	4420	1158	11500	1674		

Table 6. Rset2

XI095C275V054DNF1 Driver Rset Table

Rset2 [Ω]	Current [mA]	Rset2 [Ω]	Current [mA]	Rset2 [Ω]	Current [mA]	Rset2 [Ω]	Current [mA]
0	1000	470	1131	2400	528	12000	2284
100	1029	510	1142	2700	1575	13000	2321
110	1032	560	1154	3000	1619	15000	2383
120	1035	620	1170	3300	1661	16000	2410
130	1038	680	1185	3600	1700	18000	2458
150	1044	750	1202	3900	1737	20000	2499
160	1047	820	1218	4300	1783	22000	2534
180	1052	910	1239	4700	1826	24000	2564
200	1058	1000	1260	5100	1865	27000	2603
220	1064	1100	1282	5600	1912	30000	2635
240	1069	1200	1304	6200	1962	33000	2663
270	1077	1300	1325	6800	2008	36000	2686
300	1086	1500	1366	7500	2057	39000	2707
330	1094	1600	1386	8200	2102	43000	2730
360	1102	1800	1424	9100	2153	47000	2750
390	1110	2000	1460	10000	2199	>47000	2750
430	1121	2200	1495	11000	2244		

Table 7. 95W Driver Rset Table



Warning

Please note that changing the Rset on the module changes the current and voltage at which the module operates. You may have to adapt your design accordingly. In case no Rset is used, please check the default setting of your driver. This current may be higher than what your module can handle!

Philips Advance Xitanium Driver operating window

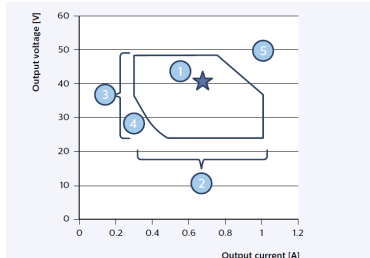

Figure 15. Example operating window of the Xitanium Driver (36W in this case)

1. Required operating point
2. Current can be set to needs within range
3. Driver adapts to required voltage, given it fits range
4. Driver minimum power limit
5. Driver maximum power limit

LED technology is rapidly evolving. Using more efficient LEDs in a next generation means the same light output can be achieved with lower currents. At the same time, LEDs can be driven at different current levels based on the application requirement. Typically, LED drivers are available in discrete current levels, e.g., 350mA, 530mA or 700mA. It is often necessary to replace a driver when more efficient LEDs become available.

One of the key features of the Philips Advance Xitanium LED Drivers is the adjustable output current (AOC), offering flexibility in luminaire design. The Xitanium Drivers can operate in a certain “operating window.” This window is defined by the maximum and minimum voltage and current that the driver can handle. An example of an operating window is shown in Figure 15 on the left. The area indicates the possible current/voltage combinations. The current you select will depend on the type and manufacturer of the LEDs or the specific LED configuration of the PCB design. The operating window of every driver can be found in the associated driver datasheets, which can be downloaded on following website: www.philips.com/ledmodulesna.

Note: by means of dimming it is possible to go below the minimum value of the specified output current.

How to determine what value the output current should be set at will be explained in the next sections.

To select an appropriate driver

Depending on your requirements, several drivers can be a solution for you. The following steps can help you in selecting a driver. Released drivers for the Fortimo LED DLM Flex Module are published in the datasheet. For a complete overview of the available drivers, please refer to the download section of www.philips.com/ledmodulesna.

1. Determine your required driver current (I_{drive}) and voltage (V_f).
2. Calculate the required power (P_{drive}) where $P_{drive} = V_f \times I_{drive}$ (W).
3. Select the datasheets from the website mentioned above based on the driver having a power greater than the required power.
4. Does the required current fit the current range of the driver? The current range of the driver can be seen in the name itself. For example, in the 25W 0.3-1A 45V, the minimum driver current is 0.3A and maximum is 1A.
 - $I_{driver\ min} \leq I_{drive} \leq I_{driver\ max}$?
5. Does the required voltage fit the voltage range of the driver? The voltage range of the driver can be seen in the name itself. For example, in the 25W 0.3-1A 45V, the maximum driver voltage is 45V and the minimum is 18V.
 - $V_{driver\ min} \leq V_f \leq V_{driver\ max}$?
6. Does the required power fit the power range of the driver? In the naming of the driver, you can see the maximum power possible. For example, in the 25W 0.3-1A 45V, the maximum power is 25W. The minimum power is defined as $I_{driver\ min} \times V_{driver\ min}$.
 - $P_{driver\ min} \leq P_{drive} \leq P_{driver\ max}$?

Choose your preferred dimming.

Possible drivers at nominal conditions

If you choose to use the modules at the nominal settings, you can use any of the following drivers listed here.

	1100 lm	1500 lm	2000 lm	3000 lm	5000 lm
Dimmable					
XI013C030V048DNM1*	○				
XI025C100V045DNMX	X	X	X		
XI036C100V048DNMX				X	
XI050C100V054DNMX**					X
XI095C275V054DNF1***					○

Table 8. Compatible System Matrix

X: UL SREC compliant system

* XI013C030V048DNM1 will set the current of module slightly lower than rated current, resulting <10% less light output for CCT 2700K, 3000K and 3500K of 1100lm module.

** XI050C100V054DNMX will set the current of module slightly lower than rated current, resulting <15% less light output for CCT 5000lm module.

*** Connecting XI095C275V054DNF1 with DLM Flex Rset and SGND terminals does not generate nominal current. Use an external Rset resistor to set XI095C275V054DNF1 at the desired current level. Rset information is in table 7.

Norms and Standards

Fortimo LED DLM Flex Module together with Philips Advance Xitanium LED Drivers comply with following norms and standards:

Safety

- UL8750/CSA C22.2 250-13 LED modules for general lighting - safety specifications
- UL1310/UL8750/CSA c22.2 no. 223 Control gear safety

Safety Related Electronic Circuit

- UL991/CSA C22.2 No. 0.8-09 Tests for Safety Related Controls Employing Solid State Safety functions incorporating electronic technology

Performance

- UL8750/SSL 7 Control gear performance

Electromagnetic compatibility (tested with Fortimo LED DLM Flex Module and Philips Advance Xitanium LED Driver)

FCC47 subpart 15 Class A Limits and methods of measurement of radio disturbance characteristics of electrical lighting and similar equipment

FCC47 subpart 15 Class A Equipment for general lighting purposes – EMC immunity requirements

ANSI C82.77 Limits for harmonic current emissions (equipment input current <16 A per phase)

Environmental

The product is compliant with European Directive 2002/95/EC of January 2003 on Restriction of the Use of Certain Hazardous Substances in Electrical and Electronic Equipment (RoHS).

ElectroStatic Discharge (ESD)

Introduction to ESD

It is generally recognized that ElectroStatic Discharge (ESD) can damage electronic components, like LED chips, resulting in early failures. Professional users of electrical components are accustomed to implementing extensive and disciplined measures to avoid ESD damage in their finished end products. Now, with the introduction of LED electronic components for lighting, a new breed of users, such as OEMs and installers, are exposed to handling and manufacturing with LED electronic components. Specifications of the LED module's maximum contact discharge level and air discharge level, according to IEC 61000-4-2 (HBM 150 pF + 330), are stated in the associated datasheets of the LED module you use and are found at www.philips.com/ledmodulesna.

ESD in your production environment

The purpose of an effective ESD control strategy is the reduction of assembly line failures, final inspection failures and field failures. Depending on the immunity level of the LED module (product specification) a minimum set of measures has to be taken when handling LED modules. ESD measures are required in a production environment where handling can exceed the ESD immunity level (product specification). Furthermore, ESD vulnerable products should be packed and shipped in ESD safe packaging. Note that air humidity has an important influence on electrostatic charge build-up.

How to meet the ESD requirement

Advice is to make use of ESD consultancy to determine how the ESD requirement can be met. One should think of an ESD control plan and ESD adequate equipment. Independent ESD consultancy companies can advise and supply adequate tools and protection guidance. For example, Philips Innovation Services can provide that consultancy.

Servicing and installing luminaires

It is highly recommended that installers are informed that they should not touch the LED components and should use earthed arm-straps to avoid ESD damage during installation and maintenance.

Approval

UL 8750, CSA and UL SREC

UV and other hazards

PET Value >100hrs /Klux (zero UV)

Damage Factor 0.08 @ 5000K

IR (infrared) Radiation As well as being free of UV radiation, the LED modules are also free of infrared radiation in the beam.

Hazard Category	Emission Limit
LB	Low (Risk group 1)
LR	Exempt*
ES	Exempt*
EUVA	Exempt*
EIR	Exempt*
EH	Pass*

Table 9. Emission List

* Exempt and Pass mean "no risk."

IEC recommendations

The general recommendations for luminaire design given by the IEC (IEC 60598) and the national safety regulations are also applicable to LED-based luminaires.

Photobiological safety aspects

As of March 2007, LEDs and LED-based products for general lighting are no longer included in the scope of the Eye Safety standard for lasers, IEC 60825-1 "Safety of laser products." The new lamp standard, IEC 62471 "Photo biological safety of lamps and lamp systems," which covers incoherent light sources, now applies. This international standard gives guidance on evaluating the photo biological safety of lamps and lamp systems including luminaires. It specifically defines the exposure limits, reference measurement technique and classification scheme for the evaluation and control of photo biological hazards from all electrically powered incoherent broadband sources of optical radiation, including LEDs but excluding lasers, in the wavelength range from 200nm to 3000nm.

In the photo biological safety standard, hazard categories are defined as follows:

*Thermal skin is not defined in IEC 62471 and hence cannot be classified in risk groups. The Fortimo LED DLM Module passes as 'no hazard during normal use' if one would rate it according IEC 60825-1 'Safety for laser products'.

Fortimo LED DLM Flex gave the following results

The following should be taken into account:

- The effective radiance measurement for Blue Light (LB) modules is "low," meaning that the LED modules are categorized in Risk Group 1. For the 3000 lumen version the permitted exposure time for Blue Light radiance (relevant when looking into the source) is limited to 1 hour, while for the 1100 lumen version it is 3 hours. Because of the Law of Conservation of Radiance, integration of the LED module into a luminaire results in either the same radiance or a reduced radiance. Final assessment of the luminaire is recommended.
- The measured irradiance-based values (E) for the categorized hazards are all within the exempt group.
- In general the permitted exposure time for irradiance is limited when in the "low," "moderate" or "high" risk group. Limiting the exposure time and/or the distance to the source can reduce the hazard level. However, for the measured LED modules no special precautions are necessary because they are ranked in the exempt group. Final assessment of the luminaire (including, e.g., secondary optics) is recommended.

Chemical compatibility

The Fortimo LED DLM Flex Module makes use of LEDs containing a silver-finished (Ag) lead frame. The lead frame finish is sensitive to pollution and/or corrosion when exposed to oxygen and certain Volatile Organic Components [VOCs]. Examples of VOCs are substances containing sulfur or chlorine. In that case parts of the lead frame may blacken, which will impair the lumen output or the color point of the LED light. Materials that are known to have a higher risk to be a source of sulfur and chlorine are, for example, rubbers used for cables and cable entries, sealings or corrugated carton. Also do NOT use adhesives, cleaning agents or coatings containing suspect VOCs. Don't use the product in aggressive (corrosive) environments that may cause damage to the LEDs.

We recommend ensuring that the direct environment of these LEDs in the luminaire does not contain materials that can be a source of sulfur or chlorine, for optimal reliability of the LED, LED module and/or LED luminaire. Furthermore, make sure that the products with these LEDs are not stored or used in vicinity of sources of sulfur or chlorine and that the production environment is also free of these materials. Also, avoid cleaning of the LED products with these types of LEDs with abrasive substances, brushes or organic solvents like acetone and TCE.

Applications of the product in industry and heavy traffic environments should be avoided in case of risk of ingress of sulfur and chlorine from the environment.

Chemical Name	Type
Acetic Acid	acid
Hydrochloric Acid	acid
Nitric Acid	acid
Sulfuric Acid	acid
Ammonia	alkali
Sodium Hydroxide	alkali
Potassium Hydroxide	alkali
Acetone	solvent
Benzene	solvent
Dichloromethane	solvent
Gasoline	solvent
MEK (Methyl Ethyl Ketone)	solvent
MIBK (Methyl Isobutyl Ketone)	solvent
Mineral Spirits (Turpentine)	solvent
Tetracholorometane	solvent
Toluene	solvent
Xylene	solvent
Castor Oil	oil
Lard	oil
Linseed Oil	oil
Petroleum	oil
Silicone Oil	oil
Halogenated Hydrocarbons (containing F, Cl, Br elements)	misc
Rosin Flux	solder flux
Acrylic Tape	adhesive
Cyanoacrylate	adhesive

Table 10. Chemical List

Humidity

Fortimo LED DLM Flex Modules and LED drivers can withstand a high humidity (93% rh) environment.

Exposure to direct sunlight

Exposure to direct sunlight during operation may have severe temperature or UV effects. Where this situation is likely, extensive temperature testing is recommended.

Vibration and shocks

Fortimo LED DLM Flex Module has been tested with:

Sine vibration

Frequency range: 10 – 150 Hz

Acceleration: 5 g_n[‡]

Amplitude: 0.35 mm peak

Sweep: logarithmic (1 octave per minute)

Number of cycles: 5 (10 sweeps)

Duration: ± 39 minutes in each direction

Number of directions: 3

Bump test

Peak acceleration: 10 g_n[‡]

Pulse duration: 16 ms

Pulse shape: half sine

Number of shocks: 1000 in each direction

Number of directions: 6

IP codes, dust and moisture protection

Fortimo LED DLM Flex Modules and LED drivers have no IP classification. The OEM is responsible for proper IP classification and approbation of the luminaire.

Philips Fortimo LED Flex Module systems are to be used for indoor applications

When used in a non-weather protected environment, additional measures shall be taken to protect the Fortimo LED DLM Flex Modules and LED drivers from water ingress.

[‡] g_n is the unit of acceleration in units of the standard gravitation acceleration gn = 9.8m/sec².

End-of-life behavior

Unlike typical conventional light sources, LEDs are not subject to sudden failure or burnout. There is no time at which the light source will cease to function. Instead, the performance of LEDs shows gradual degradation over time. When used according to specification, Fortimo LED DLM Flex Modules are predicted to deliver an average of 70% of their initial intensity after 50,000 hours of operation. The life of the system is therefore more dependent on the other electronic system components and soldering methods.

The LEDs in the Fortimo LED DLM Flex Module are connected such that if one LED fails, then the current is adjusted in order to give the same light output.

Fortimo LED DLM Flex Module system disposal

We recommend that the Fortimo LED DLM Flex Module or its components are disposed of in an appropriate manner at the end of their (economic) lifetime. The modules are essentially normal pieces of electronic equipment containing components that at present are not considered to be harmful to the environment and can be disposed of with normal care. We therefore recommend that these parts are disposed of as normal electronic waste, in accordance with local regulations.

Contact details

Philips

Product information www.philips.com/ledmodulesna

Or contact your local Philips sales representative

Partners for Cooling Solutions

Complementary Heat Sink Partner	Heat sink type
Sunon (www.sunon.com)	Active + passive
AVC (www.avc.com.tw)	Active + passive
MechaTronix (www.mechatronix-asia.com)	Active + passive
Nuventix (www.nuventix.com)	Active + passive
Wisefull (www.wisefull.com)	Active + passive

Table 11. Partners for Cooling Solutions

Partners for Reflector Solutions

Alux Luxar	www.alux-luxar.de
Jordan	www.jordan-reflektoren.de
NATA	www.nata.cn
ACL	www.reflektor.de
Almeco	www.almecogroup.com
Widegerm	www.widegerm.com.hk

Table 12. Partners for Reflector Solutions

Partners for Thermal Interface Materials

Thermal Interface Partners

Laird Technologies	www.lairdtech.com
The Bergquist Company	www.bergquistcompany.com

Table 13. Partners for Thermal Interface Materials

Disclaimer

The information in this guide is accurate at the time of writing. This guide is provided “as is” without expressed or implied warranty of any kind. Neither Philips nor its agents assume any liability for inaccuracies in this guide or losses incurred by use or misuse of the information in this guide.

Philips will not be liable for any indirect, special, incidental or consequential damages (including damages for loss of business, loss of profits or the like), whether based on breach of contract, tort (including negligence), product liability or otherwise, even if Philips or its representatives have been advised of the possibility of such damages.



©2015 Koninklijke Philips N.V. All rights reserved. Philips reserves the right to make changes in specifications and/or to discontinue any product at any time without notice or obligation and will not be liable for any consequences resulting from the use of this publication.

PLT-1502DG 2/15 philips.com

Philips Lighting
North America Corporation
10275 W. Higgins Road
Rosemont IL 60018
Tel: 800-322-2086
Fax: 888-423-1882
Customer/Technical Service:
800-372-3331
OEM Support: 866-915-5886

Imported by: Philips Lighting,
A division of Philips Electronics Ltd.
281 Hillmount Rd,
Markham, ON, Canada L6C 2S3
Tel. 800-668-9008