

# Design-in guide

Fortimo LED High Brightness Module (HBMt) Gen3



**PHILIPS**

# Contents

<b>Introduction to this guide</b>	<b>4</b>	<b>Thermal management</b>	<b>15</b>
Information and support	4	Temperature definitions	15
		Module temperature	15
<b>Introduction to the Fortimo LED HBMt Gen3</b>	<b>4</b>	Temperature measurements	18
Applications	4	Examples of standard heat sinks	18
Product description	4	Heat sink material	21
Classification	4	Thermal radiation and emissivity coefficient	21
Product range	4	Thermal interfacing	22
Fortimo LED HBMt Gen3 system NA Xitanium		Xitanium LED driver temperature	22
LED drivers	5	How to maximize system lifetime?	23
		Important points for luminaire design	23
<b>Performance specification</b>	<b>6</b>	<b>Installation instructions</b>	<b>24</b>
Module drive current, power and thermal specifications	6	Electrostatic device (ESD) measures	24
Module performance specifications	7	Mechanical fixation	24
Xitanium Programmable LED driver specification	7	Fixation of the driver	25
		Connection between module and driver	25
<b>Lighting characteristics</b>	<b>8</b>	Connecting one module to one driver	26
Light distribution	8	Connecting two modules to one driver	26
Universal mounting positions	8	Replacing a module in a 2-module system	27
Optical files	8	Using a long cable in combination with the Fortimo LED HBMt system	27
Spectral light distribution	8		
Color consistency (SDCM)	8	<b>Quality</b>	<b>28</b>
Starting characteristics	8	Compliance and approval marks	28
Lifetime characteristics	8	Sustainability	28
Specified lifetime performance	9	Conditions of acceptance	28
Flexible lumen package	9	IP rating, humidity and condensation	28
		Electromagnetic compatibility (EMC)	28
<b>Product dimensions</b>	<b>10</b>	Electrostatic discharge (ESD)	28
Fortimo LED HBMt Gen3 dimensions	10	Remote system operation	29
Xitanium LED driver dimensions	10	Use of circuit breakers: Xitanium LED drivers	29
Cable Fortimo 7PA to 6wire – 600 mm dimensions	10	Cautions on use during storage, transportation and operation	29
		System disposal	30
<b>Electrical characteristics</b>	<b>11</b>	<b>Zhaga Book 4: Flat emitter streetlight module</b>	<b>31</b>
Connection between module and driver	11	Zhaga	31
Fortimo LED HBMt Gen3 connector pins	11	Luminance properties	31
		I-10V Interface	33
<b>Important recommendations and warnings</b>	<b>12</b>	<b>Index of figures</b>	<b>34</b>
		<b>Index of tables</b>	<b>35</b>
<b>Controllability</b>	<b>13</b>	<b>Contact details</b>	<b>35</b>
Default dimming protocols	13	Philips Fortimo LED HBMt Gen3	35
Constant Light Output	13	Partners for thermal interface materials	35
Controlling Fortimo LED HBMt Gen3 with Xitanium LED drivers	14		
Which Philips controls can be used?	14		

# Introduction to this guide



Figure 1. Philips Fortimo LED high brightness module (HBMt) Gen3 system

Thank you for choosing the Philips Fortimo LED High Brightness Module (HBMt) Gen 3 System. In this guide you will find the information required to design this module into a luminaire, including valuable hints and tips.

## Information and support

On our website <http://www.philips.com/ledsystemsna> you will find not only information about this module but also design-in guide and CAD files for the Xitanium drivers. If you require any further information or support please consult your local Philips office or visit:

Fortimo LED HBMt product details and CAD files  
[www.philips.com/leddrivers](http://www.philips.com/leddrivers)

Xitanium drivers  
[http://www.usa.lighting.philips.com/connect/LED\\_modules/led\\_drivers.wpd](http://www.usa.lighting.philips.com/connect/LED_modules/led_drivers.wpd)

General information for OEMs  
[www.philips.com/ledmodulesna](http://www.philips.com/ledmodulesna)



# Introduction to the Fortimo LED HBMt Gen3



Figure 2. Fortimo LED HBMt Gen3 6000 lumen



Figure 3. Xitanium 150W driver



Figure 4. Cable Fortimo 7PA to 6wire - 60 mm

## Applications

Philips Fortimo LED High Brightness Module (HBMt) Gen 3 System has been primarily developed for outdoor applications but can also be used indoors. The 3rd generation offers a drop-in replacement of Philips Fortimo LED High Brightness Module (HBMt) Gen 2 System on mechanics, optics and electrics.

## Product description

To operate a system the following products are needed:

- Fortimo LED High Brightness Module
- Compatible Philips Advance Xitanium LED Driver, see Table 2
- Cable 60 cm

## Classification

The Fortimo LED High Brightness Module (HBMt) Gen 3 System with Xitanium driver can be used in:

- Non-Class 2, UL system

## IMPORTANT USAGE NOTES

- Minimum drive current = 100 mA. If dimmed below 100 mA, Philips does not guarantee the specified product performance
- Maximum drive current depends on the specific module (please refer to Table 6). This limit must be observed in all cases, including CLO
- Tcase must not exceed stated maximum for the application, regardless of drive current
- $\Delta$  (Tcase -Tmax.ambient) must not exceed stated maximum for the application, regardless of drive current
- The correct values of Tcase and  $\Delta$ T (Tcase -Tmax.ambient) are specified according the application (outdoor/indoor)
- Failure to comply with usage conditions will void product warranty and will negatively impact product lifetime and performance

Table 1. Product range

Product Name	I2NC	EOC
Fortimo LED HBMt 4000/740 33W Gen3	929000882806	871829174461000
Fortimo LED HBMt 4000/757 33W Gen3	929000882606	871829174467200
Fortimo LED HBMt 4000/840 34W Gen3	929000882406	871829174477100
Fortimo LED HBMt 6000/740 49W Gen3	929000882706	871829174463400
Fortimo LED HBMt 6000/757 49W Gen3	929000882506	871829174475700
Fortimo LED HBMt 6000/840 51W Gen3	929000882306	871829174483200
Cable Fortimo 7PA to 6wire - 600mm	929000803903	871829121412000

## Fortimo LED HBMt Gen3 system with Xitanium LED drivers

Table 2. 1 module

1 Module	Driver	Part Number	Cable
4000 lm (all CCT/CRI combinations)	Xitanium 40W 0.53A Prog+ GL-J sXt	9290 007 10303	Cable Fortimo 7PA to 6wire – 600mm
4000 lm (all CCT/CRI combinations)	Xitanium 75W 0.1A-0.7A AOCM 0-10V INT-Y sXT	XI075C070V105DNYI	Cable Fortimo 7PA to 6wire – 600mm
6000lm (all CCT/CRI combinations)	Xitanium 75W 0.1A-0.7A AOCM 0-10V INT-Y sXT	XI075C070V105DNYI	Cable Fortimo 7PA to 6wire – 600mm
6000lm (all CCT/CRI combinations)	Xitanium 75W 0.35A-0.7A Prog GL sXt	9290 007 02302	Cable Fortimo 7PA to 6wire – 600mm
6000lm (740 and 757)	Xitanium 75W 0.1A-0.53A AOCM 0-10V sXt	XI075C053V140DNYI	Cable Fortimo 7PA to 6wire – 600mm
6000lm (740 and 757)	Xitanium 75W 0.53A INT-Y 0-10V sXT	XI075C053V140CNYI	Cable Fortimo 7PA to 6wire – 600mm

Table 3. 2 modules

2 Modules	Driver	Part Number	Cable
2x 4000 lm (all CCT/CRI combinations)	Xitanium 75W 0.35A-0.7A Prog GL sXt	9290 007 02302	Cable Fortimo 7PA to 6wire – 600mm
2x 4000 lm (all CCT/CRI combinations)	Xitanium 75W 0.1A-0.53A AOCM 0-10V sXt	XI075C053V140DNYI	Cable Fortimo 7PA to 6wire – 600mm
2x 4000 lm (all CCT/CRI combinations)	Xitanium 75W 0.53A INT-Y 0-10V sXT	XI075C053V140CNYI	Cable Fortimo 7PA to 6wire – 600mm
2x 6000lm (all CCT/CRI combinations)	Xitanium 150W 0.53A-0.7A Prog GL sXt	9290 007 02202	Cable Fortimo 7PA to 6wire – 600mm
2x 6000lm (740 and 757)	Xitanium 150W 0.53A Isolated Dim	LEDINTA0530C280DO	Cable Fortimo 7PA to 6wire – 600mm
2x 6000lm (740 and 757)	Xitanium 150W 0.53A Non-Isolated Dim Input Voltage 347–480V	LEDHCNA0530C280DN	Cable Fortimo 7PA to 6wire – 600mm

Table 4. 3 modules

3 Modules	Driver	Part Number	Cable
3x 4000 lm (all CCT/CRI combinations)	Xitanium 150W 0.53A-0.7A Prog GL sXt	9290 007 02202	Cable Fortimo 7PA to 6wire – 600mm
3x 4000 lm (all CCT/CRI combinations)	Xitanium 150W 0.53A Isolated Dim	LEDINTA0530C280DO	Cable Fortimo 7PA to 6wire – 600mm
3x 4000 lm (all CCT/CRI combinations)	Xitanium 150W 0.53A Non-Isolated Dim Input Voltage 347–480V	LEDHCNA0530C280DN	Cable Fortimo 7PA to 6wire – 600mm

Table 5. 4 modules

4 Modules	Driver	Part Number	Cable
4x 4000 lm (740 and 757)	Xitanium 150W 0.53A-0.7A Prog GL sXt	9290 007 02202	Cable Fortimo 7PA to 6wire – 600mm
4x 4000 lm (740 and 757)	Xitanium 150W 0.53A Isolated Dim	LEDINTA0530C280DO	Cable Fortimo 7PA to 6wire – 600mm
4x 4000 lm (740 and 757)	Xitanium 150W 0.53A Non-Isolated Dim Input Voltage 347–480V	LEDHCNA0530C280DN	Cable Fortimo 7PA to 6wire – 600mm

As the Xitanium LED driver portfolio is always growing to include new products, please contact your Philips sales representatives.

# Performance specification

## Module drive current, power and thermal specifications

The following paragraphs contain the performance specifications of the Fortimo LED High Brightness Module (HBMt) Gen 3 System.

Note:

- All product performances are specified at  $T_{case} = 85^{\circ} C$
- $\pm 10\%$  tolerance applies to lumen specifications
- Philips maintains a tolerance  $\pm 6.5\%$  on luminous flux measurements.
- Specifications are compliant with Zhaga Book 4 <sup>2</sup>

Table 6. Output current, power and thermal specifications <sup>1</sup>

Module	Rset drive current, (mA)	Pmax @Rset	Pthermal max@Rset	Pmax drive current (mA)	Pmax@max drive current	Pthermal max@max drive current
Fortimo LED HBMt 4000/740 33W Gen3	530	35	22	550	36	23.5
Fortimo LED HBMt 4000/757 33W Gen3	530	35	22	550	36	23.5
Fortimo LED HBMt 4000/840 34W Gen3	530	36	23	550	37.5	24.5
Fortimo LED HBMt 6000/740 49W Gen3	530	53	33.5	550	55	35
Fortimo LED HBMt 6000/757 49W Gen3	530	53	32.5	550	55	35
Fortimo LED HBMt 6000/840 51W Gen3	550	55	35	550	55	35



### Warnings

- Driving the module above stated maximum drive current voids product warranty and may have negatively affect product performance or lifetime
- Driving the module above stated maximum drive may negatively affect product performance and lifetime
- $T_{case}$  and  $\Delta T$  limits as specified in the Thermal management section must be observed for all drive currents

1. Specifications are subject to change, for the latest specifications please contact your local Philips Sales Representative  
 2. Go to [www.zhagastandard.org](http://www.zhagastandard.org)

# Module performance specifications

## Fortimo LED HBMt Gen3 4000 lumen

Table 7. Fortimo LED HBMt Gen3 specifications 4000 lumen

Specification	4000/740	4000/757	4000/840	Unit
Flux	4000	4000	4000	Lm
Drive current	530	530	530	mA
CCT	70	70	80	K
Color consistency	<7(1/4 ANSI)	<7(1/4 ANSI)	<7(1/4 ANSI)	SDCM
Tcase	85	85	85	°C
Lifetime @Tcase 90%survivals	50,000	50,000	50,000	Hrs
Light-emitting surface (LES)	60x15	60x15	60x15	Mm
Current pins	7	7	7	-
Current setting	Rset1 or Rset2	Rset1 or Rset2	Rset1 or Rset2	-
Approbation	CE, ENEC, cUЯus	CE, ENEC, cUЯus	CE, ENEC, cUЯus	-

Table 8. Performance specifications Fortimo LED HBMt Gen3 4000 lumen

Product	Luminous fFlux, min (lm)	Luminous flux, typical (lm)	Luminous flux, max (lm)	Efficacy, typical (lm/W)	Power, typical (W)	Power, max (W)	Thermal power, typical (W)	Max Input, Voltage (V)
4000/740 33W	3600	4050	4400	125	32.5	35	20	66
4000/757 33W	3600	4150	4400	128	32.5	35	19	66
4000/840 34W	3600	4050	4400	119	34	36	21	68

Table 9. Fortimo LED HBMt Gen3 specifications 6000 lumen

Specification	4000/740	4000/757	4000/840	Unit
Flux	6000	6000	6000	Lm
Drive current	530	530	550	mA
CCT	70	70	80	K
Color consistency	<7(1/4 ANSI)	<7(1/4 ANSI)	<7(1/4 ANSI)	SDCM
Tcase	85	85	85	°C
Lifetime @Tcase 90%survivals	50,000	50,000	50,000	Hrs
Light-emitting surface (LES)	60x15	60x15	60x15	Mm
Current pins	7	7	7	-
Current setting	Rset1 or Rset2	Rset1 or Rset2	Rset1 or Rset2	-
Approbation	CE, ENEC, cUЯus	CE, ENEC, cUЯus	CE, ENEC, cUЯus	-

Table 10. Performance specifications Fortimo LED HBMt Gen3 6000 lumen

Product	Luminous fFlux, min (lm)	Luminous flux, typical (lm)	Luminous flux, max (lm)	Efficacy, typical (lm/W)	Power, typical (W)	Power, max (W)	Thermal power, typical (W)	Max Input, Voltage (V)
6000/740 49W	5400	6100	6600	124	49	53	30	100
6000/757 49W	5400	6200	6600	127	49	53	29	100
6000/840 51W	5400	6000	6600	118	51	55	32	100

## Xitanium Programmable LED driver specification

For the latest Xitanium Programmable LED driver specifications, please refer to the individual product datasheet or the portfolio leaflet on [www.philips.com/ledsystemsna](http://www.philips.com/ledsystemsna).

# Lighting characteristics

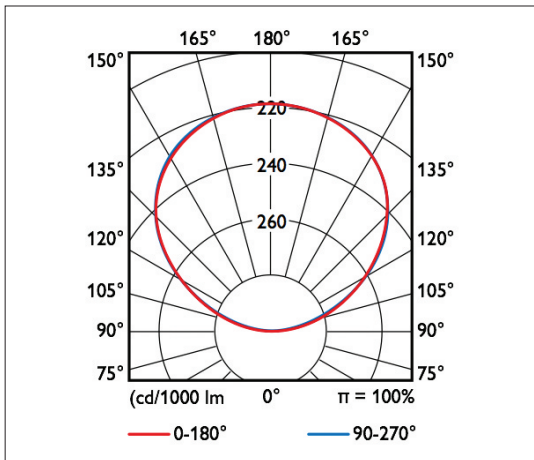

Figure 5. Polar diagram Fortimo LED HBMt Gen3

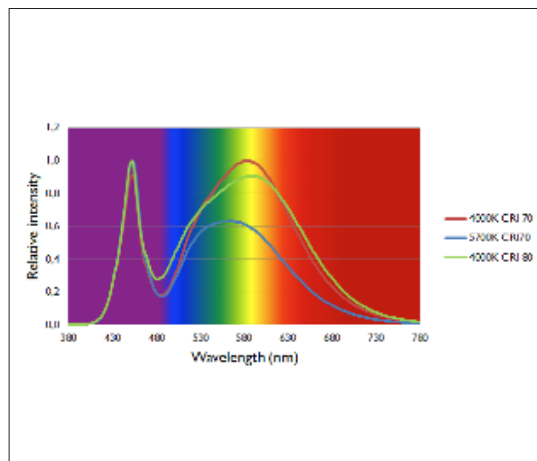

Figure 6. Spectral light distribution for the Fortimo LED HBMt Gen3

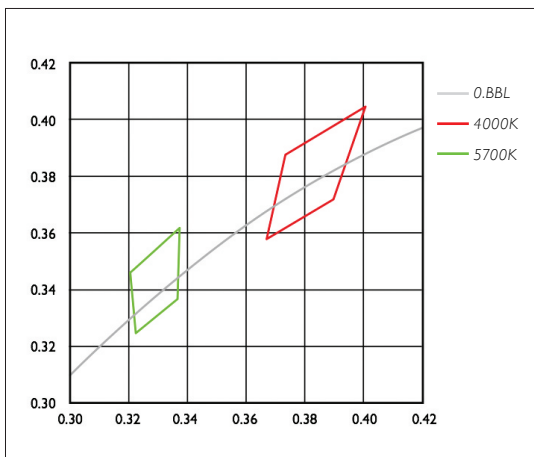

Figure 7. Color consistency (1/4 ANSI)  
Figure 7 shows color targets for the different color temperatures of the Fortimo LED HBMt Gen3. These are specified in the operating conditions  $T_c = 85^\circ C$ ,  $\Delta T (T_{case} - T_{max.amb}) \leq 50^\circ C$ . In the application a color shift is possible if the case temperature is significantly different than specified.

## Light distribution

The Fortimo LED High Brightness Module (HBMt) Gen 3 System provides lambertian light distribution, making it suitable for a variety of applications, e.g. street lighting, area lighting, urban lighting and architectural flood lighting. The light distribution can be best controlled using a specular/near-specular reflector.

## Universal mounting position

The mounting direction of the Fortimo LED module is universal. For applications where a narrow batwing-like distribution is required, we recommend the modules be used in pairs to make optimal use of the module beam.

## Optical files

Optical files in IES format, including Ray-sets, can be downloaded from the Fortimo LED HBMt webpage ([http://www.lighting.philips.com/us\\_en/connect/LED\\_modules/fortimo-HBMt.wpd](http://www.lighting.philips.com/us_en/connect/LED_modules/fortimo-HBMt.wpd)).

The photometric files can be used to check the system's far-field intensity distribution. The initial reflector or luminaire design can be carried out using a lambertian emitter to gain simulation speed. The final design should always be verified using a simulation executed with a Ray-set for the module.

## Spectral light distribution

### Color consistency (SDCM)

The target specification of the Fortimo LED HBMt Gen3 System for color consistency is within ANSI C78.377. This specification is similar to that of conventional discharge lamps used in outdoor lighting. The ANSI C78.377 has an approximate value of 7 SDCM, or Standard Deviation of Color Matching. This value refers to the size of an ellipse around the black body locus.

## Starting characteristics

After ignition or re-ignition of the driver the module will immediately produce the intended amount of light.

## Lifetime characteristics

Fortimo LED HBMt Gen3 System has expected lifetime of 50,000 operating hours with 90% survivals. Table 17 provides typical lumen output at end of life.

Table 11. Fortimo LED HBMt Gen3 lumen maintenance

Product name (all CRI/Cc combinations)	Initial lumen output (lm)	Typical lumen output @50K hours (lm)
Fortimo LED HBMt Gen3 4000 lm	4000	3400
Fortimo LED HBMt Gen3 6000 lm	6000	5100



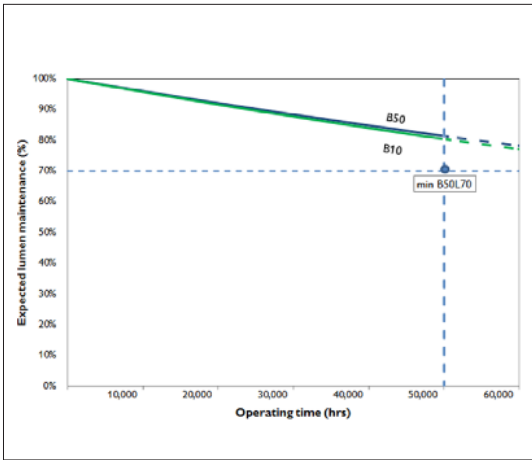

Figure 8. Fortimo LED HBMt Gen3 lumen maintenance,  $T_{case} = 85^{\circ}C$  and  $T(T_{case}-T_{max.ambient}) \leq 50^{\circ}C$

**Note:** Lifetime performance specifications are based on 1 switching cycle per day and 4,000 burn hours per year, as conditioned for warranty. Operating the modules under deviating conditions may result in different lifetime, lumen maintenance or survival rates.

#### Specified lifetime performance

Figure 8 shows the expected lumen maintenance during a product lifetime. B50L70 indicates the minimum expected lumen maintenance level.

#### Flexible lumen package

LED drive current required to achieve the specified lumen package is specified in Table 6. In a system with Xitanium Programmable LED drivers, it is possible to achieve a light output different from the stated lumen package. By programming the Adjustable Output Current (AOC) in a linear relationship to the stated module Rset current, different lumen packages can be achieved. Maximum LED drive current allowed for each module is stated in Table 6.

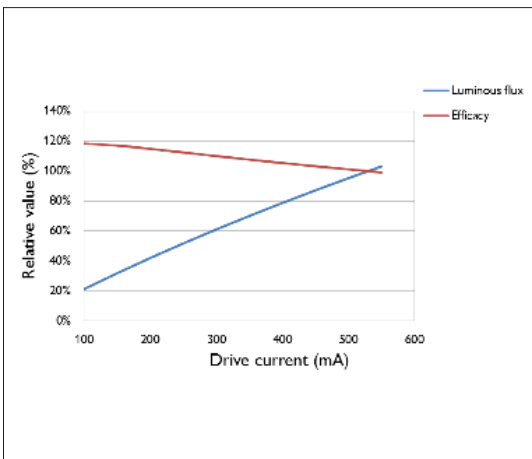

Figure 9. Fortimo LED HBMt Gen3 flux and efficacy vs. LED drive current, 4000 and 6000 lumen



#### Warnings

- Programming AOC above the stated maximum LED drive current (refer to Table 6) for the module type voids product warranty and will negatively impact lifetime performance.

#### Fortimo LED HBMt Gen3 Module - 4000 and 6000 lumen

Operating the Fortimo LED HBMt Gen3 at lower than specified  $T_{case}$  will increase both the lumen output and the efficacy of the module. Figure 10 shows the relative increase in performance.

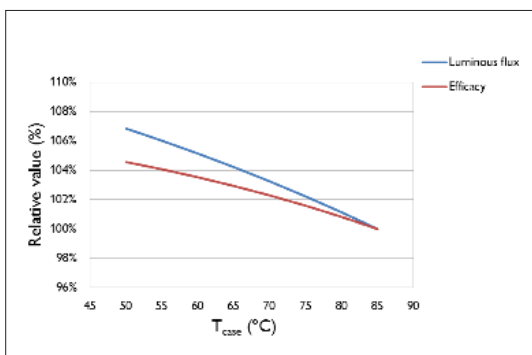

Figure 10. Fortimo LED HBMt Gen3 flux and efficacy vs.  $T_{case}$

# Product dimensions

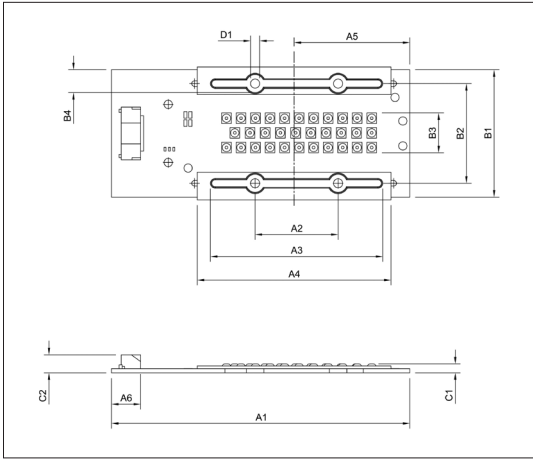

Figure 11. Fortimo LED HBMt Gen3 module



Figure 12. Cable Fortimo 7PA to 6wire - 600mm

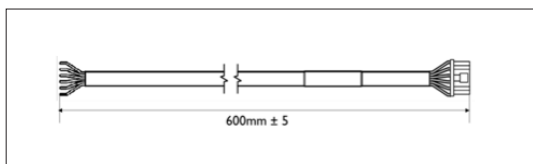

Figure 13. Cable Fortimo 7PA to 6wire - 600mm

## Fortimo LED High Brightness Module dimensions

The module consists of a PCB assembly with LEDs and additional components.

Table 12. Fortimo LED High Brightness Module dimensions

Dimensions in mm (NOMINAL±0.2MM)	A1	A2	A3	A4	A5	A6	B1	B2	B3	B4	C1	C2	D1
Fortimo LED HBMt, all types	107.8	30	58.8	70	41.4	13.5	46	36	14.5	6.2	4	8	3.3

## Philips Advance Xitanium LED driver dimensions

Please refer to individual Xitanium LED driver specifications for complete information on mechanical dimensions and performance specifications.

## Cable Fortimo 7PA to 6wire – 600 mm dimensions

The module can be connected to Xitanium LED drivers (Table 2-3) using a 7-pin-to-wire cable (Figure 13).

# Electrical characteristics



Figure 14. Cable Fortimo 7PA to 6wire - 600 mm

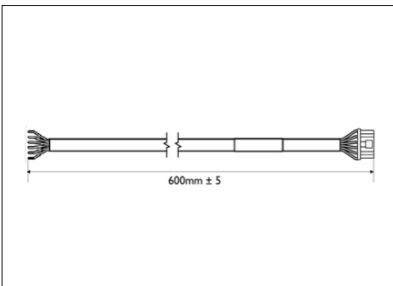

Figure 15. Cable Fortimo 7PA to 6wire - 600 mm (929000803903)

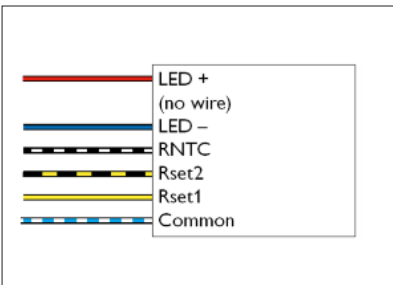

Figure 16. Cable wiring to driver

## Connection between module and driver

The Fortimo High Brightness Module is compatible with both Rset1 and Rset2 Xitanium LED drivers. Using the Rset on the module with these drives, will provide an output current specified for the module type.

We advise to use the Fortimo LED HBMt Gen3 in combination with the Xitanium LED drivers mentioned in Tables 2 to 5 (approved combinations).

## Cable

The module can be connected to the driver using the cables specified in Tables 2 to 5.

Table 13. Fortimo 7PA to 6wire cable color coding

Connector pin	Function	Color coding drive/cable
Pin 1	LED+	Red
Pin 2	-	No wire
Pin 3	LED-	Blue
Pin 4	RNTC	Black/White
Pin 5	Rset2	Yellow/Black
Pin 6	Rset1	Yellow
Pin 7	Common	Blue/White

**Note:** The Rset2 wire should be left unconnected when Rset1 drivers are used, and vice versa.

Table 14. Fortimo LED HBMt Gen3 connector pins

Connector	Signal	Destruction
Pin 1	IDC	LED driver current input
Pin 2	(HV spacer)	Not connected
Pin 3	PGND	Power ground
Pin 4	NTC	Temperature sensor (RNTC) resistor in series
Pin 5	Rset2	Resistor for current setting of LED driver type Rset2
Pin 6	Rset1	Resistor for current setting of LED driver type Rset1
Pin 7	SGND	Signal ground

**Note:** It is possible to connect two or more modules in series to one Xitanium driver by using multiple cables. It is important to note that the driver can only communicate with one of the modules (master/slave), see Installation instructions.

# Important recommendations and warnings

The following recommendations and warnings should be taken into account when using Fortimo LED High Brightness Modules and Xitanium LED drivers.



## Important usage conditions

- Minimum drive current = 100 mA. If dimmed below 100 mA, Philips does not guarantee product performance
- Maximum drive current is defined in Table 6. This limit must be observed in all cases including CLO, or product warranty is voided.
- $T_{case}$ ,  $\Delta T$ , must not exceed specified maximum for each usage case, regardless of drive current
- Failure to comply with usage conditions will void product warranty

## Design-in phase

- It is mandatory to design the luminaire in such a way that it can only be opened with special tools (by electricians) in order to prevent accidental contact with live parts
- Safety and UL/CSA recommendations: the general UL/CSA recommendations for luminaire design and national safety regulations (NEC) also apply to selected Fortimo LED HBMt modules and Xitanium driver. Luminaire manufacturers are advised to conform to the safety standards for luminaire design (UL1598-Luminaires)
- The luminaire must be constructed in such a way that the LED module cannot be touched by the end-user (safety)
- Do not apply mains power directly to the LED module

## Design-in and manufacturing phase

- Do not use damaged or defective modules
- Do not touch LEDs. Take ESD precautions
- Do not put extra force on the LED modules while screwing them in the luminaire (respect assembly prescription)
- Do not drop the LED module or let any object fall on top of the module as this may damage the insulation layer of the LED board. Do not use the LED module if it has been dropped or an object has fallen on it and there are visible defects or damage

## Installation and service phase of luminaires

- The luminaire should not be serviced when the mains voltage is connected; this includes connecting or disconnecting the cable.

# Controllability

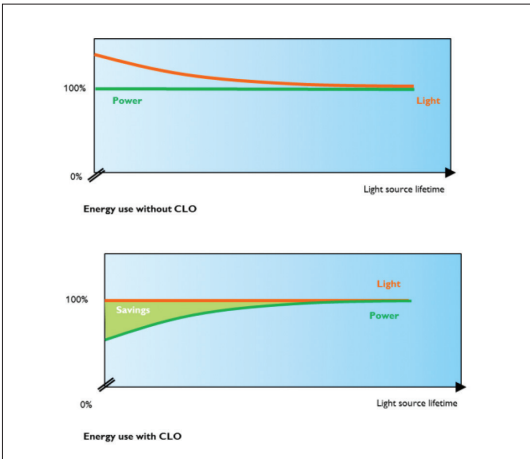

Figure 17. Energy savings with CLO

## Default dimming protocols

The Fortimo LED HBMt Gen3 module is dimmable with a range of integrated light control options.

- Adjustable Output Current
- Constant Light Output
- I-10V, AmpDim, DALI and Dynadimmer dimming

Specific features will depend on the Philips Advance LED driver system selected (Tables 2-3). Please visit [www.philips.com/ledsystemsna](http://www.philips.com/ledsystemsna) for complete information on the integrated light control options available in the Xitanium product range.

**Note:** Although it is technically possible to dim Fortimo LED HBMt Gen3 modules below 100mA, Philips does not specify product performance for modules operating below this current.

## Constant Light Output

There are minimum light level requirements for public lighting. In order to compensate for lumen depreciation, which occurs in all light sources over time, the lighting design is often over-lit at the beginning of the source's lifetime.

It is possible to deliver energy savings by avoiding over-lighting and still ensuring the minimum expected light level over the lifetime of the module if the Constant Light Output (CLO) feature in Xitanium Programmable drivers is used.

The CLO feature uses a predictive algorithm to increase the output current to the module over the specified lifetime of 50,000 hours\*. As the current increases, the energy consumption also increases. The CLO feature can be combined with other dimming protocols for even greater energy savings.

Programming CLO in Fortimo LED High Brightness Module Gen 3 will ensure minimal light levels without wasting energy in the beginning of module's life.

Please use Table 15 to program the CLO curve for Fortimo LED HBMt Gen3.

Table 15. Fortimo LED High Brightness Module CLO curve, all module types

Module working hours	Power level
0	85%
4,000	86%
8,000	87%
12,000	89%
16,000	90%
20,000	91%
24,000	92%
28,000	93%
32,000	95%
36,000	96%
40,000	97%
50,000	100%

\* Average rated life is based on engineering data testing and probability analysis. The hours are at the B50, L70 point - 50,000 hours life with 70% lumen maintenance at Tc point of 56°C for 3R and 61°C for 1R.





#### Warning!

- Using CLO will deliver the typical lumen output at end of module's life, constant over the whole lifetime, not the specified initial lumen output of the module. For example, programming CLO with a Fortimo LED High Brightness Module 6000lm will provide a stable 5100lm over the expected life of the module, NOT 6000lm over the expected life of the module
- Warranty will apply only when the CLO is programmed according to Table 15

#### Controlling Fortimo LED High Brightness Module with Xitanium LED drivers

Xitanium LED drivers allow the use of several control protocols, including 1-10V, DALI, Integrated Dynadimmer and CLO. Fortimo LED HBMt modules can be used with both Rset1 and Rset2 LED drivers.

Further details on programming can be found in the Design-in guide for Xitanium LED Programmable Drivers. The Design-in guide can be downloaded via our website at [www.philips.com/ledsystemsna](http://www.philips.com/ledsystemsna).

#### Which Philips controls can be used?

Further information about our entire portfolio of control products is available at [http://www.lighting.philips.com/us\\_en/connect/controls/index.wpd](http://www.lighting.philips.com/us_en/connect/controls/index.wpd).

# Thermal management

The critical thermal management points for the module and driver are set out in this chapter in order to facilitate the design-in of the Fortimo LED HBMt Gen3. Keeping these thermal points in mind will help to ensure the optimal performance and lifetime of the system.

Table 16. Thermal definitions

Item	Description	Symbol	Unit
Ambient temperature	Temperature of the air surrounding the luminaire in the test environment or application	Tamb	°C
Maximum rated luminaire ambient temperature	Maximum rated luminaire temperature of the air surrounding the luminaire in the application	Tmax.amb	°C
Case temperature	The representative temperature of a module or driver, defined at a specific position on the module or driver	Tcase	°C
Module temperature	The temperature measured at the specified Tcase position on the module	-	°C
Driver temperature	The temperature measured at the specified Tcase position on the driver	-	°C
Delta T	The maximum temperature difference between Tcase and Tmax.amb	ΔT	°C

**Note:** In order to ensure accurate Tcase test results, the case temperature should not vary by more than 1° C for a period of at least 30 minutes after a stable temperature has been achieved.

## Module temperature

To achieve typical product lifetime characteristics, it is critical to ensure that the product is operating within specified temperature limits. These limits depend on both the product and the application, including luminaire design and maximum rated luminaire ambient temperature.

### Thermal specifications

To ensure the optimal performance and life time of the system. The following conditions have to meet:

- Maximum  $T_{case} \leq 85^{\circ} C$  at maximum rated luminaire ambient temperature
- $T (T_{case} - T_{max. amb}) \leq 50^{\circ} C$  (Maximum allowed difference between case and rated luminaire ambient temperature)

Table 17. Determining maximum  $T_{case}$  for an application

Maximum rated luminaire ambient temperature	Maximum $\Delta T (T_{case} - T_{amb})$	Maximum $T_{case}$
40° C	45° C	85° C
55° C	30° C	85° C
30° C	50° C	80° C

### Outdoor applications, $T_{max.amb} = 40^{\circ} C$

When the maximum outdoor ambient ( $T_{max.amb}$ ) is 40° C, the luminaire design needs to ensure that

- Module temperature does not exceed 85° C when tested in a lab environment at 40° C ambient
- $\Delta T$  must not exceed 45° C

### Indoor applications, $T_{max.amb} = 30^{\circ} C$

When the maximum indoor ambient ( $T_{max.amb}$ ) is 30° C, the luminaire design needs to ensure that

- Module temperature does not exceed 80° C when tested in a lab environment at 30 °C ambient
- $\Delta T$  must never exceed 50° C

### High Bay or Industrial applications, $T_{max.amb} = 55^{\circ} C$

If the given luminaire operates under indoor conditions (e.g. high-bay or industrial application  $T_{max. amb}$  is rated for 55° C), the luminaire design needs to ensure that

- Module temperature does not exceed 85° C when tested in a lab environment at 55° C ambient
- $\Delta T$  must never exceed 30° C

### Thermal de-rating

The Fortimo High Brightness Module contains a thermal de-rating system to detect overheating and extreme lifetime degradation of the LEDs when operated outside the maximum permitted temperature conditions. Such conditions can be caused by extreme ambient conditions or inadequate heat management design. The thermal de-rating is based on temperature detection on the module. When multiple modules are connected to 1 driver, one module is in the “master” mode and the others are in the “slave” mode. It is strongly recommend that the module with the highest Tcase in the application is used as the “master” module.

### How does it work?

The thermal de-rating system is a default feature in some Philips Advance Xitanium LED drivers. When the case temperature rises above the specified limit, the driver switches to a lower LED output current. When the case temperature drops below the specified limit, the system will resume normal operation.



#### Warning!

- MTP is only a failsafe in order to protect the module against overheating during peaks in ambient temperature or in the event of a faulty heat sink design. Optimum performance will only be achieved if the Tcase meets the thermal boundaries stated above and measured according to the procedure described below
- MTP diagnostic feature cannot be used for Tcase measurements
- Not all drivers have the thermal de-rating system, please refer to individual Xitanium LED driver specification

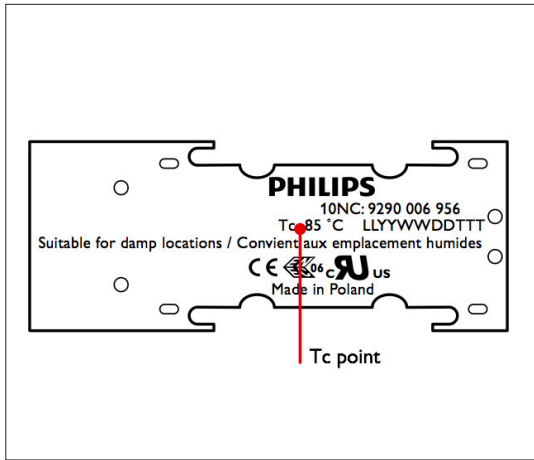

Figure 18. Temperature test point on bottom PCB

When the module is used in combination with Xitanium LED drivers, the default driver profile will ensure the correct Module Temperature Protection (MTP) settings.

The thermal de-rating feature will be triggered above a case temperature of 85° C.

**Note:** The default MTP setting for Xitanium Programmable LED drivers is “Philips LED Light Engine”. This setting offers optimized profile for use with all Philips LED modules, including Fortimo LED HBMt, for maximum Tcase. For best system performance, we advise not changing the default profile or the dimming curve

The Philips LED Light Engine profile is defined for module operated with a Tcase=85° C. For use in applications where a lower Tcase must be reached, please contact your Philips representative for guidelines.

#### Temperature measurements

The maximum ambient temperature at which the luminaire will operate constitutes the initial key criterion for defining the correct temperature limit and validating the thermal luminaire design.

#### Example for outdoor applications:

If the desired maximum operating ambient temperature is 40° C or lower, the luminaire design needs to ensure that the module temperature does not exceed 85° C when tested in a lab environment at 40° C ambient.

For indoor applications, the luminaire design needs to ensure that the module temperature does not exceed 85° C and meet a maximum  $\Delta T$  between the module and ambient of  $\leq 50^\circ \text{C}$ .

If the desired maximum operating ambient temperature is 25° C or lower, the luminaire design needs to ensure that the module temperature does not exceed 75° C when tested in a lab environment at 25° C ambient. Maximum  $\Delta T$  meets 50° C.

**Note:** The ambient temperatures are referring to the average ambient temperatures around the luminaire during the operational period of the module.

#### Critical temperature point (Tcase)

For LEDs, the junction temperature is the critical factor for operation. Since there is a direct relation between the case temperature and the LED junction temperature, it is sufficient to measure the aluminum casing of the Fortimo LED HBMt at its critical temperature point, see Figure 19.

If the case temperature at the Tcase point exceeds the specified maximum Tcase, this will have an adverse effect on the performance of the LEDs and the Fortimo LED HBMt module in terms of light output, lifetime and lumen maintenance.



### Measurement of critical temperature point

It is important that the T<sub>case</sub> point is free of thermal interface material when the thermo couple is connected for temperature measurements. It is essential to have a stable connection between the thermal couple and the module. Any shifting of the thermal couple will result in measurement errors and poor measurement repeatability.

The temperature must be stable before any reliable data can be obtained (depending on the size and material of the luminaire, between 30 and 180 minutes).

It is possible to measure the temperature in three different ways through a thermocouple connected to the indicated T<sub>case</sub> point on the back of the module.

#### 1. Preferred method: Via a groove in the module mounting surface:

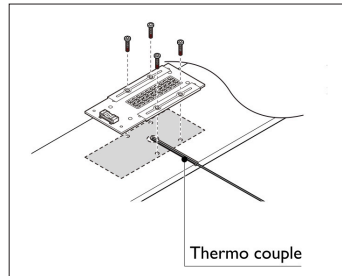

Figure 19. T<sub>case</sub> measurement via thermocouple in a groove

#### 2. Via an access point cut through the mounting surface of the module:

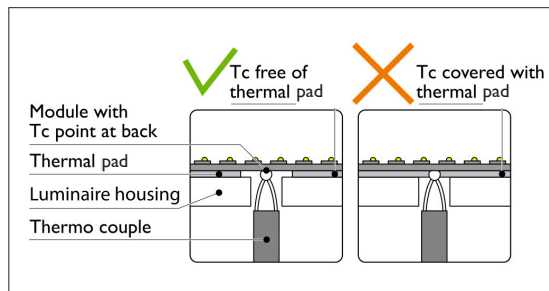
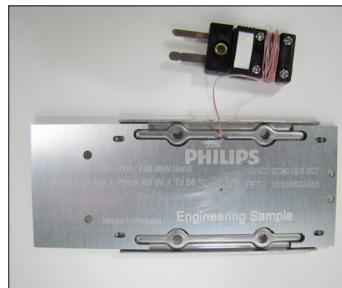

Figure 20. T<sub>case</sub> measurement via an access point

#### 3. 40 gauge Thermocouple in-bedded inside of the module's aluminum substrate:



40 gauge Thermocouple

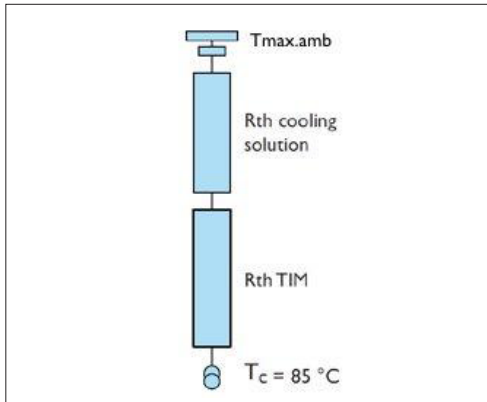

Figure 21. Thermal network



Figure 22. AVC heat sinks which can be used in combination with Fortimo LED HBMt<sup>3</sup>

### Designing a cooling solution

Conceptually a cooling solution can be represented with a series of thermal resistances, connecting the heat source to the ambient. Good thermal design can be seen as minimizing the thermal path from heat source to the ambient.

The thermal performance of a luminaire is mainly determined by two major parts, the heat sink or main heat dissipating body and the thermal interface which will shortly be discussed in the following section.

### Heat sink design

The module is primarily designed for metal luminaires, in which the luminaire housing may double as the heat sink. The main purpose of the heat sink in the thermal chain is to dissipate heat into the surrounding ambient. To do this efficiently a heat sink's main task is to increase the area in contact with the surrounding ambient.

Table 18 provides an indication for the required effective cooling area per HBMt module.

Table 18. Fortimo LED HBMt typical cooling surface requirements (x1000 mm<sup>2</sup>)

Maximum rated luminaire ambient temperature (T <sub>max. amb</sub> )	4000lm /840	4000lm /740	4000lm /757	6000lm /840	6000lm /740
25° C	106-127	103-123	97-117	164-197	155-185
35° C	127-159	123-154	117-146	197-246	185-232
45° C	159-212	154-205	146-195	246-329	232-309

3. Suggested products which can be used with Fortimo LED HBMt systems. Reference to these products does not constitute endorsement by Philips.

### Heat sink material

The type of material used has a significant influence on the final result. For example, a comparison of the thermal conductivity (k) of copper with that of corrosion-resistant steel (see Table 19) shows that a substantially smaller heat sink can be made with copper. The best material for heat sink is (soft) aluminum. The thickness (H) of the heat sink is also of major importance. If identical heat sinks made from different materials were used, a similar effect would be achieved with 1 mm copper, 2 mm aluminum, 4 mm brass, 8 mm steel and 26 mm corrosion-resistant steel.

Table 19. Thermal conductivity

Material	W/mK
Copper	400
Aluminum	200
Brass	100
Steel	50
Corrosion-resistant steel	15

In summary a thermally more conductive material helps heat spreading over the body and activates more effective cooling area.

### Thermal radiation and emissivity coefficient

Thermal radiation accounts for a substantial part of the total heat transfer. The amount of thermal radiation is highly dependent on the emissivity coefficient of the surface. For example, a polished aluminum surface has a very low emissivity coefficient, while a painted surface has a very high one. A higher emissivity coefficient means more effective heat transfer.

Table 20. Thermal emissivity coefficients of common materials

Material	Finish	Emissivity coefficient
Aluminum	New/polished	0.04-0.06
	Blank	0.20-0.30
	Anodized	0.80-0.95
Steel	New/polished	0.1
	Painted/coated	0.80-0.95

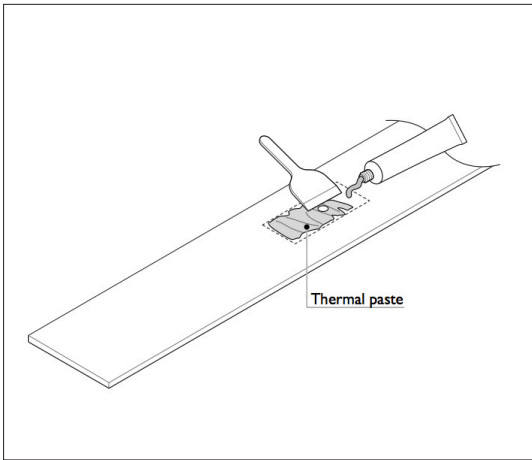

Figure 23. Interface between module and mounting plate filled with thermal paste

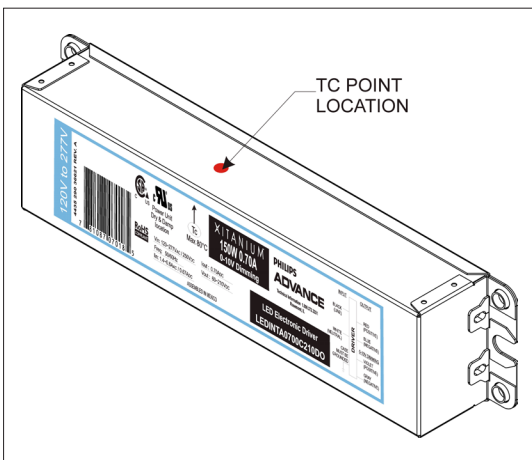

Figure 24. Label on the Xitanium driver indicates Tcase point

### Thermal interfacing

The thermal interface is a critical item for design-in of Fortimo LED HBMt system. The module's small area in combination with the relatively high thermal load translates into high power densities, which increase the impact of the thermal interface on the total system.

The thermal interface is the interface between the module and the mounting surface in the luminaire. To ensure good thermal contact, the contact area should be covered with thermal interface material, e.g. thermal paste, Figure 23.

Around 50 micron thickness of thermal paste, equality spread on the total flat surface of the heatsink is advised.

If the use of thermal paste is not appropriate, and some other thermal interface material is used (e.g. phase change, graphite, or thermal pad) it is strongly recommended to follow installation instructions for the selected interface materials.



#### Warning!

- The use of thermal interface materials other than thermal paste might require the use of higher efficiency heat sink
- Applying excessive thermal paste does not result in improved thermal management. For best performance, it is essential to follow the guidelines above

### Xitanium LED driver temperature

The next key component is the driver, which influences the lifetime and reliability of the system. It is important to ensure good thermal and electrical contact between the driver and the luminaire as this enables the heat to dissipate efficiently and allows the driver to deliver optimal electrical performance. The driver temperature can be measured with a thermocouple at the Tcase point, shown on the driver label, Figure 24.

### Critical driver temperature point with respect to CLO

When the Fortimo LED High Brightness Module is used with Philips Advance Xitanium Programmable LED drivers, usage of the CLO feature will increase the output current. As a result, the driver losses will increase accordingly, which in turn will lead to a higher driver Tcase temperature. For the thermal design it is therefore important to ensure that the Tcase temperature of the driver is within specification for its Tcase max at end of life.

Please refer to individual product datasheets for Tcase information for lifetime.

#### How to maximize system lifetime?

- Ensure good thermal contact between module, driver and the coldest part of the luminaire
- Place module(s) and driver at a distance from each other to obtain a more homogeneous temperature distribution in the luminaire
- It is recommended that the modules are mounted on an aluminum housing that is at least 3 mm thick; thinner housings will limit the heat flow through the housing, while thicker housings will improve the heat flow through the luminaire, resulting in a lower Tcase of the module

#### Important points for luminaire design

- When multiple modules are used, it is recommended they are spread out in the luminaire, in order to distribute the thermal load
- Reflectors should be used in the design of optics
- In order to accommodate every application, Fortimo LED High Brightness Modules can be dimmed or used in pairs to optimize the lumen package
- Simplify the heat path from modules to ambient air. Limit the number of thermal interfaces in the primary heat path towards the ambient air
- If thermal interfaces are inevitable, use thermal interface materials (TIM) to ensure proper thermal contact, i.e. between module and luminaire housing
- Ensure proper heat dissipation by using highly conductive materials and/or materials of sufficient thickness to maximize effective use of the available cooling surface
- Use anodized, painted surfaces rather than blank surfaces in order to increase the transfer of heat via thermal radiation



# Installation instructions

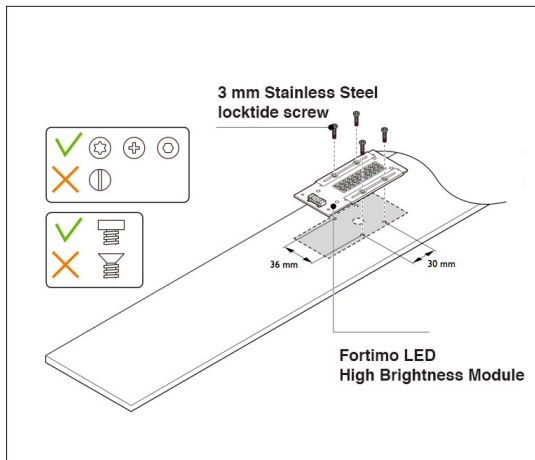

Figure 25. Fixation of the HBMt module



## Warning!

The Fortimo LED HBMt Gen3 should always be replaced by a trained installer. Special attention should be paid to the following points:

- Do not service the system when the mains voltage is connected; this includes connecting or disconnecting the cable
- Before a new Fortimo LED HBMt is mounted, the old thermal interface must be removed and the area must be cleaned

## Mechanical fixation

The separate components (driver and module(s)) of the Fortimo LED HBMt Gen3 system can be fixed in place securely using the mounting holes located on the module(s) and driver. Please refer to the dimensional drawings for specific details.

Before affixing the Fortimo LED HBMt Gen3, ensure that the mounting surface is clean and flat without any protrusions or pits. To ensure a reliable thermal and mechanical attachment, we recommend the flatness of the mounting surface should be  $\leq 0.2$  mm.

For the best thermal performance use a thin layer of thermal paste (max 50 micron) between the module and the mounting surface. The entire bottom surface of the module needs to be covered with thermal paste, with a typical bond line of 30 to 50 microns. Other thermal interface materials can be used but will require more cooling from the luminaire (i.e. larger contact area between the luminaire and the ambient).

Use 4 M3 fasteners for the brackets and apply a torque of  $0.6 \text{ Nm} \pm 0.1 \text{ Nm}$ . Screw the module on the luminaire/heatsink by fixating the screws in diagonal following order, this to spread the force over the total module.

**Note:** When stainless steel fasteners are used in combination with an aluminum luminaire, depending on local conditions, galvanic corrosion between the metal parts can occur without preventative measures. It is strongly advised to use a wax or lubricant.

If fasteners cannot be used or are not accessible, another mounting option is to use a spring clip for each bracket. The spring clip will press uniformly the bracket onto the LED module. In this situation, use the complete length of the pressed groove from the bracket for the clip. Press force for each clip on position of the bracket is  $1000 \text{ Nm} \pm 100 \text{ Nm}$ .

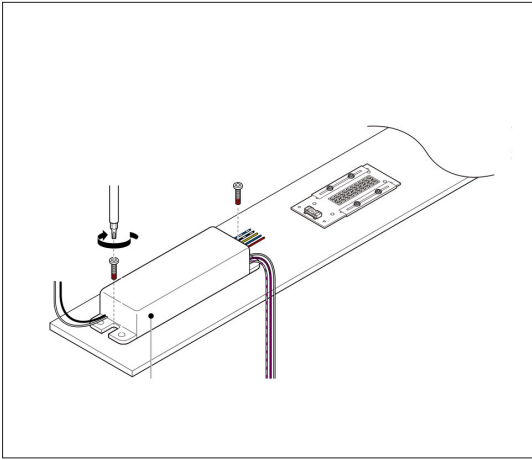

Figure 26. Fixation of the Xitanium driver

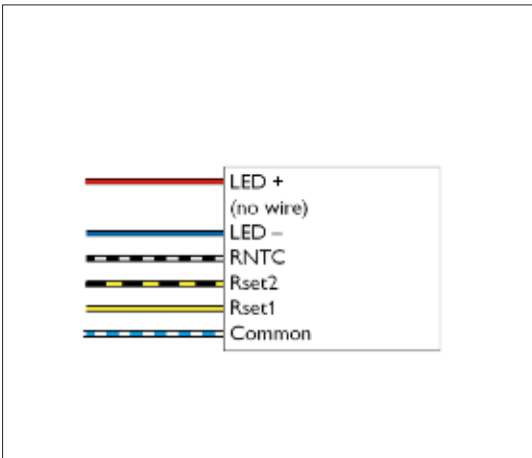

Figure 27. Fortimo LED HBMt Gen3 connector wiring towards LED driver

#### Fixation of the driver

The Xitanium driver has fixation holes on the short ends of the casing. The driver should be mounted securely on a flat area of the luminaire, using the mounting hole on each side of the driver.

#### Connection between module and driver

A cable is available to connect the module to the driver; the color coding of the cable wires has been aligned with the color coding of the driver wires to ensure easy installation. Figures 27 – 30 show the details of the HBMt cable and the color-coded wires on the driver.

#### Fortimo LED HBMt Gen3 wiring

Table 21. Fortimo LED HBMt cable color coding

Connector pin	Function	Color coding driver/cable
Pin 1	LED+	Red
Pin 2	-	No wire
Pin 3	LED-	Blue
Pin 4	RNTC	Black/White
Pin 5	Rset2	Yellow/Black
Pin 6	Rset1	Yellow
Pin 7	Common	Blue/White

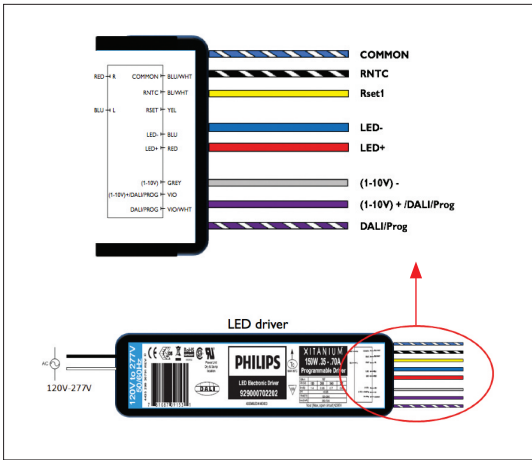

Figure 28. Wire color coding on Xitanium Programmable LED driver with Rset1

### Connecting one module to one driver

A standard cable is available for connecting the module to a driver. The color coding of the wires in this cable corresponds to that in the Xitanium driver. If a set-up with a single module and a single driver is used, the corresponding colors need to simply be connected.

The unused Rset wires should be clipped short and wrapped with an insulating material e.g. a fiberglass insulating sleeve.

### Connecting two modules to one driver

It is possible to connect two HBMt modules in series to one Xitanium LED driver by using two cables.

It is important to note that the driver can only communicate with one of the modules.

This means that output current setting and Module Temperature Protection read-out are only available on one of the two modules.

The unused Rset wires should be clipped short and wrapped with an insulating material e.g. a fiberglass insulating sleeve.

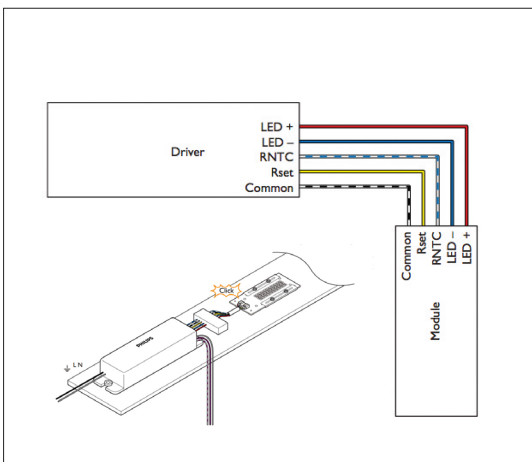

Figure 29. Color coding (one module connected to one Rset1 driver)

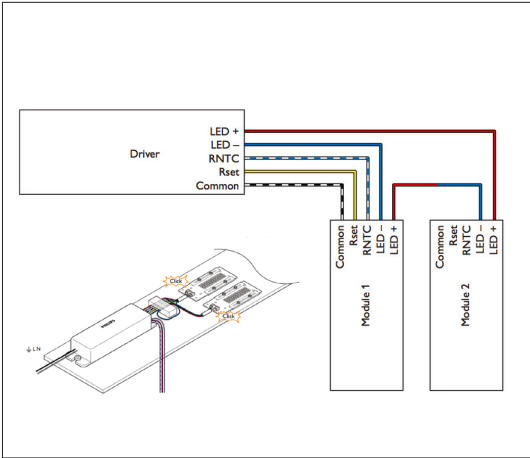

Figure 30. Color coding (two modules connected to one Rset driver)

### Replacing a module in a 2-module system

Special attention is required when replacing a module in 2 modules/1 driver configuration. Due to the fact that the driver can only read out information from a single module, in case of failure we recommend replacing both modules, as current settings can vary from batch to batch over time as LED performance improves. If the installer does not replace both modules it is possible that one of the modules will be driven at the wrong current and will not produce the specified lumen output. Production date code on the module label identifies the batch.

### Using a long cable in combination with the Fortimo LED HBMt system

It is possible to use a connection between module/s and driver longer than the standard 60cm cable. When using AWG24 cables, the connection can be extended up to 10 meters without affecting the power supply to the module. It is not advised to use the communication wires because of possible interferences.

- Do not use Rset - output current needs to be programmed in the driver
- Module Temperature Protection (RNTC) function cannot be used
- Do not use the Common wire
- Design-in support is available; please contact your Philips sales representative



#### Warning!

When using a long cable between module and driver, extra care should be taken in the design of EMI, surge and noise suppression

## Compliance and approval marks

The Philips Fortimo LED HBMt is UL and CSA approved and complies with the applicable EU directives.

To ensure approval of the luminaire, the conditions of acceptance need to be fulfilled. Module-related data can be found in CSA 250-13 and UL8750. All luminaire manufacturers are advised to conform to the international standards of luminaire design (CSA 250-13 or ULI598).

## Sustainability

Fortimo LED High Brightness Modules are compliant with European Directive 2011/65/EU, recasting 2002/95/EC on Restriction of the Use of Certain Hazardous Substances in Electrical and Electronic Equipment (RoHS). The modules comply with Reach, as defined by the EU Chemical Agency.

## Conditions of acceptance

Details can be requested from your local sales representative.

## IP rating, humidity and condensation

The Fortimo LED High Brightness Modules are build-in systems and therefore have no IP classification. They are not designed for operation in the open air. The OEM is responsible for proper IP classification and approbation of the luminaire.



### Warning!

- The Fortimo LED HBMt has been developed and released for use in damp locations
- Do not use in locations where condensation is present.
- If there is a possibility that condensation could come into contact with the modules, the system/luminaire builder must take precautions to prevent this

## Electromagnetic compatibility (EMC)

Electromagnetic compatibility, EMC, is the ability of a device or system to operate satisfactorily in its electromagnetic environment without causing unacceptable interference in practical situations. In general, LED modules have no effect on the EMC of a luminaire. The Fortimo LED HBMt was tested with a Xitanium driver in a reference luminaire and no EMC issues were observed.

## Introduction to Electrostatic discharge (ESD)

It is generally recognized that Electro Static Discharge can damage electronic components, like LED chips, resulting in early failures. Professional users of electronic components are used to implementing extensive and rigorous measures to prevent ESD damage in their finished products. With the introduction of LED components for lighting, a new breed of users, such as OEMs and installers, are now involved in handling and using electronic LED components in the manufacturing process.



### ESD in the production environment

Depending on the immunity level of the LED board, there is a minimum set of measures that have to be implemented when handling LED boards. ESD measures are required in a production environment where handling can exceed the ESD immunity level. Furthermore, products that are susceptible to ESD must be packed and delivered in ESD-safe packaging.

The purpose of an effective ESD-control strategy is to reduce line failures, final inspection failures and field failures.

### ESD specifications

Philips designed HBMt module Gen3 products to be robust when exposed to ESD. The maximum permitted contact discharge level and air discharge level, according to IEC 61000-4-2 (HBM 150pF + 330 ), is 8 kV contact and 15 kV air.

### Servicing and installing luminaires

It is highly recommended that installers are instructed not to touch the LED components and to use earthed arm straps to prevent ESD damage during installation and maintenance.

### ESD consultancy

Independent ESD consultancy companies can advise and supply adequate tools and protection guidance.

### Remote system operation

Please consult the design-in guide for Xitanium LED drivers.

### Use of circuit breakers: Xitanium LED drivers

Please consult the design-in guide for Xitanium LED drivers at [http://www.lighting.philips.com/us\\_en/connect/LED\\_modules/xitanium\\_programmable.wpd](http://www.lighting.philips.com/us_en/connect/LED_modules/xitanium_programmable.wpd)

### Cautions on use during storage, transportation and operation

- Store in a dark place
- Do not expose to sunlight
- Maintain temperature between -40 to +85° C
- Relative humidity (RH) between 5 and 85%

### During operation

Fortimo LED HBMt must be operated within the specifications found in the product datasheet and design-in guide. Please contact your local sales representative for additional information.

### System disposal

We recommend that the Fortimo LED High Brightness Module and its components are disposed of in an appropriate way at the end of their (economic) lifetime. The modules are in effect normal pieces of electronic equipment containing components that are currently not considered to be harmful to the environment. We therefore recommend that these parts are disposed of as normal electronic waste, in accordance with all federal, state and local laws and regulations.

# Zhaga Book 4: Flat emitter streetlight module



Figure 31. Zhaga logo

## Zhaga

Zhaga is a global consortium formed by companies from across the lighting industry. The overriding aim is to bring standardization to applications in general lighting by creating well-defined interface specifications. This ensures the interchangeability of LED light sources from different manufacturers. All Fortimo LED high brightness module Gen2 (HBMt) products are Zhaga certified. For more information on Zhaga, please refer to the website: <http://www.zhagastandard.org> for complete details.

## Luminance properties

The LED Module shall emit light of a Lambertian distribution in the direction perpendicular to the mechanical reference plane. The luminance distribution of the LLE is described by the following characteristics:

- Vertical symmetry
- Horizontal symmetry
- Center balance
- Uniformity

To enable a proper characterization of the luminance distribution, the LES is subdivided into 8 areas A1 to A8, in which average luminance is measured with an imaging luminance measuring device. Each of these areas covers one eighth of the whole LES. These areas allow the calculation of the above relevant uniformity factors without counting the single LEDs which may be placed in an arbitrary variety inside the light emitting surface.

## Luminance Uniformity Parameter U

The uniformity parameter U is determined by first calculating the average and Root Mean Square (RMS) of the Luminance  $L_j$  of every pixel  $j$  inside the LES whereby  $N$  equals the number of pixels:

$$L_{avg} = (\sum L_j) / N$$

$$LRMS = \sqrt{(\sum (L_j)^2) / N}$$

The uniformity parameter U is calculated as  $U = L_{avg} / LRMS$

## Maximum total thermal power of the module

Maximum thermal power generated by the LED module (unit: W). The maximum thermal power equals the maximum electrical power (unit: W) that is supplied to the LED module minus the minimum optical power (unit: W). The optical power ( $P_{vis}$ , unit: W) is the radiant flux of the LED module in the wavelength range from 380nm up to 780nm (unit: W).

### Maximum Thermal power @ thermal interface

The LED Module generates an amount of heat which is represented by the max thermal Power as:

$$P_{th, \max} = P_{th, \text{rear}, \max} + P_{th, \text{front}, \max}$$

The major portion ( $P_{th, \text{rear}}$ ) is transferred via the Thermal Interface Surface by heat conduction. The  $P_{th, \text{front}}$  portion is transferred by means of IR radiation and convection in the direction of the light beam.

### Maximum Allowable Thermal resistance of the Luminaire

Value of the thermal resistance from the Thermal Interface Surface to the environment for which holds:  $T_r = T_{r, \max}$  (unit: K/W). This value is to be defined by the manufacturer as the temperature at which the Rated LED Module performance is specified.

$T_r = t_a + R_{th} * P_{th, \text{rear}}$  where  $t_a$  is the average temperature of the air in the vicinity of the Luminaire and  $R_{th}$  is the thermal resistance from the Thermal Interface Surface to the environment.

### Rated Operating Temperature $T_{r, \max}$

The Reference Temperature  $T_r$  is the temperature at the TIM-Heatsink interface of a LED module that is thermally connected to the heatsink with this TIM (unit: K). In practice this temperature is measured in the heatsink near the TIM-Heatsink interface. The case temperature  $T_{\text{case}}$  is related to this reference temperature  $T_r$  as follows:

$$T_{\text{case}} = T_r + R_{th, \text{TIM}} * P_{th, \text{LED Module}}$$

The Rated Operating Temperature,  $T_{r, \max}$ , is the value of the Reference Temperature ( $T_r$ ) at which the rated values are specified.

Table 22. Zhaga luminous flux categories

Flux category	Luminous Flux [lm]	
	Minimum	Maximum
C011	990	1,320
C025	2,250	3,000
C040	3,600	4,800
C060	5,400	7,200
C080	7,200	9,600
C100	9,000	12,000

### Recommended Zhaga-compliant Xitanium LED drivers

Product name	ECG Zhaga Category	System Safety Compliance
Xitanium 40W 0.70A Prog+GL-J sXt	DS2	Class I, II
Xitanium 75W 0.7A AOCM I-10V GL-Y sXt	CL1	Class I, II
Xitanium 75W 0.35-0.7A GL Prog sXt	BL1	Class I, II
Xitanium 150W 0.35-0.7A GL Prog sXt	BL1	Class I, II

Flat emitter streetlight module product specifications.

Table 23. Zhaga Book 4 specifications

Zhaga specification	4000lm 740	4000lm 757	4000lm 840	6000lm 740	6000lm 757	6000lm 840
Number of LED modules	1	1	1	1	1	1
Luminous Flux Category	C040	C040	C040	C060	C060	C060
LES dimensions [mm]	58.80x14.5	58.80x14.5	58.80x14.5	58.80x14.5	58.80x14.5	58.80x14.5
LES category	3	3	3	3	3	3
Uniformity (UL)	0.336	0.324	0.338	0.403	0.407	0.41
Vertical Symmetry (SymmL,v)	0.961	0.985	0.991	0.971	0.967	0.98
Horizontal Symmetry (SymmL,h)	0.998	0.962	0.983	0.923	0.983	0.974
Center Balance (BalL,cent)	1	0.899	0.977	0.947	0.889	0.877
Correlated Color Temperature [K]	4000	5700	5700	4000	5700	5700
CRI value [Ra]	CRI>70	CRI>70	CRI>70	CRI>70	CRI>70	CRI>70
P <sub>th, rear</sub> [W]	21.5	20.5	22.2	32.5	31.4	34.5
R <sub>th, max</sub> [K/W] at Ta 25°C	4.4	3.69	3.69	2.33	2.49	2.03
t <sub>r, max</sub> (°C)	85	85	85	85	85	85
I-10V dimming interface	yes	yes	yes	yes	yes	yes
safety categories	A3,B2	A3,B2	A3,B2	A3,B2	A3,B2	A3,B2
Torque for attaching LED module to	0.6 Nm +/- 0.1Nm	0.6 Nm +/- 0.1Nm	0.6 Nm +/- 0.1Nm	0.6 Nm +/- 0.1Nm	0.6 Nm +/- 0.1Nm	0.6 Nm +/- 0.1Nm

For Zhaga compliance testing, the recommended Thermal Interface Material (TIM) is Laird HR620 TIM applied with a thickness < 50 micron and 0.75W/mK.

#### I-10V Interface

Fortimo LED HBMt Module System drivers offer a I-10V dimming interface. A tolerance of ±10% applies to the estimated typical lumen output.

# Index of figures

Figure 1. Philips Fortimo LED high brightness module (HBMt) Gen3 system	3
Figure 2. Fortimo LED HBMt Gen3 6000 lumen	4
Figure 3. Xitanium 150W driver	4
Figure 4. Cable Fortimo 7PA to 6wire - 60 mm	4
Figure 5. Polar diagram Fortimo LED HBMt Gen3	8
Figure 6. Spectral light distribution for the Fortimo LED HBMt Gen3	8
Figure 7. Color consistency ( $\frac{1}{4}$ ANSI)	8
Figure 8. Fortimo LED HBMt Gen3 lumen maintenance, $T_{case} = 85^{\circ} \text{C}$ and $T (T_{case}-T_{max.ambient}) \leq 50^{\circ} \text{C}$	9
Figure 9. Fortimo LED HBMt Gen3 flux and efficacy vs. LED drive current, 4000 and 6000 lumen	9
Figure 10. Fortimo LED HBMt Gen3 flux and efficacy vs. $T_{case}$	9
Figure 11. Fortimo LED HBMt Gen3 module	10
Figure 12. Cable Fortimo 7PA to 6wire - 600mm	10
Figure 13. Cable Fortimo 7PA to 6wire - 600mm	10
Figure 14. Cable Fortimo 7PA to 6wire - 600 mm	11
Figure 15. Cable Fortimo 7PA to 6wire - 600 mm (929000803903)	11
Figure 16. Cable wiring to driver	11
Figure 17. Energy savings with CLO	13
Figure 18. Temperature test point on bottom PCB	18
Figure 19. $T_{case}$ measurement via thermocouple in a groove	19
Figure 20. $T_{case}$ measurement via an access point	19
Figure 21. Thermal network	20
Figure 22. AVC heat sinks which can be used in combination with Fortimo LED HBMtI	20
Figure 23. Interface between module and mounting plate filled with thermal paste	22
Figure 24. Label on the Xitanium driver indicates $T_{case}$ point	22
Figure 25. Fixation of the HBMt module	25
Figure 26. Fixation of the Xitanium driver	28
Figure 27. Fortimo LED HBMt Gen3 connector wiring towards LED driver	25
Figure 28. Wire color coding on Xitanium Programmable LED driver with RsetI	26
Figure 29. Color coding (one module connected to one RsetI driver)	26
Figure 30. Color coding (two modules connected to one RsetI driver)	26
Figure 31. Zhaga logo	31

# Index of tables

Table 1. Fortimo LED HBMt Gen3 system components (excluded drivers)	4
Table 2. Fortimo LED HBMt Gen3 system with Xitanium LED drivers: 1 module	5
Table 3. Fortimo LED HBMt Gen3 system with Xitanium LED drivers: 2 modules	5
Table 4. Fortimo LED HBMt Gen3 system with Xitanium LED drivers: 3 modules	5
Table 5. Fortimo LED HBMt Gen3 system with Xitanium LED drivers: 4 modules	5
Table 6. Output current, power and thermal specifications	6
Table 7. Fortimo LED HBMt Gen3 specifications 4000 lumen	7
Table 8. Performance specifications Fortimo LED HBMt Gen3 4000 lumen	7
Table 9. Fortimo LED HBMt Gen3 specifications 6000 lumen	7
Table 10. Performance specification Fortimo LED HBMt Gen3 6000 lumen	7
Table 11. Fortimo LED HBMt Gen3 lumen maintenance	8
Table 12. Fortimo LED HBMt Gen3 dimensions	10
Table 13. Fortimo 7PA to 6wire cable color coding	11
Table 14. Fortimo LED HBMt Gen3 connector pins	11
Table 15. Fortimo LED HBMt Gen3 CLO curve, all module types	13
Table 16. Thermal definitions	15
Table 17. Determining maximum Tcase for an application	16
Table 18. Fortimo LED HBMt typical cooling surface requirements (x1000 mm <sup>2</sup> )	20
Table 19. Thermal conductivity	21
Table 20. Thermal emissivity coefficients of common materials	21
Table 21. Fortimo LED HBMt cable color coding	25
Table 22. Zhaga Book 4 luminous flux categories	32
Table 23. Zhaga Book 4 specifications	33

## Contact details

The following are suggestions of products that can be used with the Fortimo LED HBMt Gen3 systems. Reference to these products does not constitute their endorsement by Philips. Philips makes no warranties regarding these products and assumes no legal liability or responsibility for loss or damage resulting from the use of the information herein.

[www.philips.com/outdoor](http://www.philips.com/outdoor), [www.philips.com/technology](http://www.philips.com/technology) or contact your local Philips sales representative

### Partners for thermal interface materials

Asia Vital Components Co., LTD

[www.avc.com.tw](http://www.avc.com.tw)

The Bergquist Company [www.bergquistcompany.com](http://www.bergquistcompany.com)

Laird Technologies [www.lairdtech.com](http://www.lairdtech.com)

### Disclaimer

The information in this guide is accurate at the time of writing. This guide is provided “as is” without express or implied warranty of any kind. Neither Philips nor its agents assume any liability for inaccuracies in this guide or losses incurred by use or misuse of the information in this guide.

Philips will not be liable for any indirect, special, incidental or consequential damages (including damages for loss of business, loss of profits or the like), whether based on breach of contract, tort (including negligence), product liability or otherwise, even if Philips or its representatives have been advised of the possibility of such damages.



© 2014 Koninklijke Philips N.V.  
All rights reserved.  
Specifications are subject to change without notice.

PLt-1432DG 07/14

[www.philips.com/ledsystems](http://www.philips.com/ledsystems)

Philips Lighting  
North America Corporation  
10275 W. Higgins Road  
Rosemont, IL 60018  
Tel: 800-322-2086  
Fax: 888-423-1882  
Customer Support/  
Customer Care: 800-372-3331

Imported by: Philips Lighting  
A division of Philips Electronics Ltd  
281 Hillmount Road  
Markham ON, Canada L6C 2S3  
Phone: 800-668-9008