

**PHILIPS
ADVANCE**

LED Drivers

Design-in Guide

CertaDrive

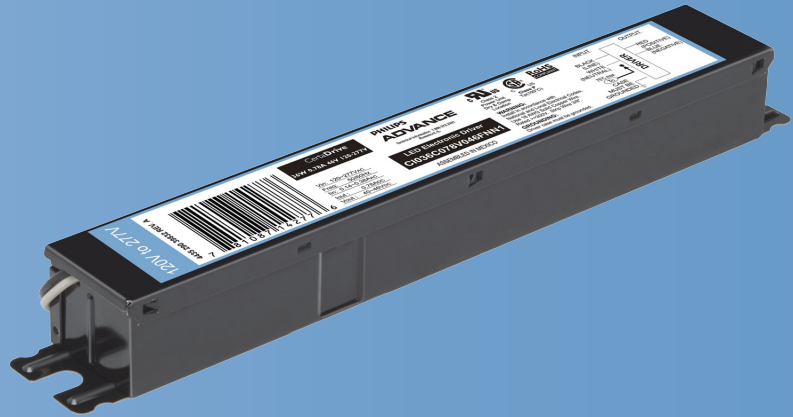

The **affordable & reliable choice** for easy indoor luminaire design-in

CertaDrive LED drivers

Contents

Introduction to this guide	3
Applications	3
Information or support	3
Safety precautions	4
Safety warnings and installation instructions	4
Introduction to CertaDrive indoor LED drivers	5
Introduction	5
CertaDrive value and creation	5
How to select an appropriate CertaDrive driver for your modules	6
Product naming	7
Electrical design-in	8
Surge protection	8
Leakage current	8
Electromagnetic compatibility (EMC)	9
Electrical isolation	10
Inrush current	10
Thermal design-in	11
Case Temperature Point (Tc point)	11
Mechanical mounting	12
Disclaimer	13

Introduction to this guide



Examples of CertaDrive indoor LED drivers.

Thank you for choosing Philips Advance CertaDrive indoor LED drivers. In this guide you will find the information needed to integrate these drivers into a LED luminaire or LED system.

This edition describes the CertaDrive indoor LED drivers optimized for indoor application. We advise you to consult our websites for the latest up-to-date information.

Applications

The CertaDrive indoor LED drivers are designed to operate LED solutions for indoor lighting, like offices, public buildings and retail environments. If you use Philips Advance LED drivers in combination with Philips LED modules, specific design-in guides are available from below mentioned technology websites.

Information or support

Please consult your local Philips office or visit:
<http://www.philips.com/oemna>

Safety precautions



Warnings:

- Avoid touching live parts!
- Do not use drivers with damaged wiring!

Safety warnings and instructions to be taken into account during design-in and manufacturing include:

- Do not use damaged or defective contacts or housings.
- Do not service the driver when the mains voltage is connected; this includes connecting or disconnecting the LED load.
- Do not use damaged products.
- Cap off all unused wires to prevent accidental contact with the luminaire or driver housing.
- The luminaire manufacturer is responsible for its own luminaire design and has to comply with all relevant safety standards.
- The Philips Advance CertaDrive LED driver is intended for built-in use and should not be exposed to the elements such as snow, water or ice. Exposure will lead to corrosion of the driver housing and should be avoided. It is the luminaire manufacturer's responsibility to prevent exposure. CertaDrive indoor LED drivers are specified for UL damp and dry locations.
- Driver must be installed in accordance with national and local electrical codes.
- For support with any of these aspects, please contact your local Philips sales representative.

Introduction to CertaDrive indoor LED drivers



CertaDrive indoor LED drivers.

Introduction

Philips Advance CertaDrive indoor LED drivers are designed to meet basic general lighting need in commercial applications. Offered in specific voltage – current settings, these drivers are optimized with elementary specifications that are just appropriately suited for the application, making LED conversion even more attainable.

Within prescribed operating windows, CertaDrive drivers provide the OEM with the ability to match their LED board specifications with discrete voltage–current combinations that can be offered as fixed-current derivatives for both non-dimmable and dimmable applications.

CertaDrive value and creation

CertaDrive value proposition

Within the prescribed range supported by a released platform, CertaDrive enables fast time to market for customized solutions with specific (non-programmable) current and voltage settings for the LED module.

CertaDrive creation

Prior to creating any CertaDrive solution a platform must first be created. This platform consists of a predefined range or window of current and voltage. From this platform, any CertaDrive with a specific current and voltage settings can be created for as long as those values for voltage and current fall within the window or platform boundaries. See examples in Figure 1.

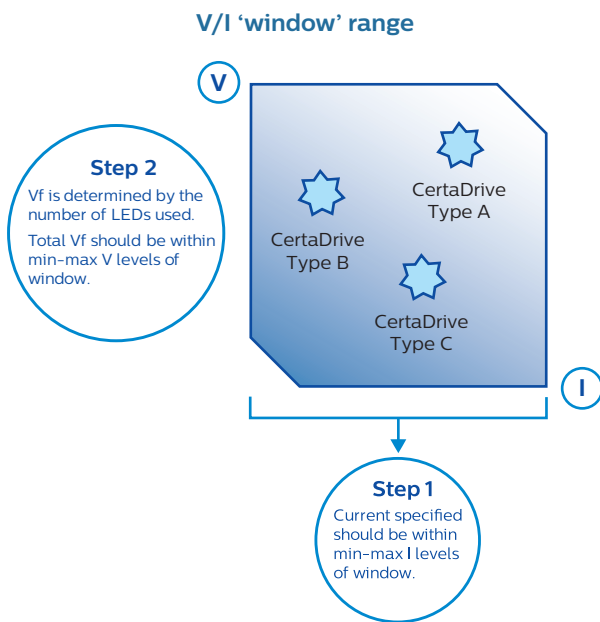

Figure 1. Flexibility to create specific and dedicated CertaDrive designs.

How to select an appropriate CertaDrive driver for your modules

Depending on your requirements several drivers can be found as a solution for you. The following steps can help selecting the preferred driver.

1. Determine your required drive current (I_{drive}) and voltage (V_f _range* of LED load).
2. Calculate required power via: $P_{drive} (W) = V_f (V) \times I_{drive} (A)$.
3. Does required current fit current range of driver?
- $I_{driver\ minimum} < I_{drive} < I_{driver\ maximum}$?
4. Does required voltage fit voltage range of driver?
- $V_{driver\ minimum} < V_f_range < V_{driver\ maximum}$?
5. Does required power fit power range of driver?
- $P_{driver\ minimum} < P_{drive} < P_{driver\ maximum}$?
6. Choose your type of dimming (0-10V** or non-dimmable).

* Note: the selection of the V_f _range take into account the tolerance factors for LED binning, temperature, aging, etc.

** Note: 0-10V dimmable version of CertaDrive models will be available in the future.

Product naming

C	I	036	0078	V46	F	N	N	1	M
									Packaging: M=Midpack, I=Individual Pack, B=Bulk Pack
									Version Control: 1=Version 1, 2=Version 2, ...
									Enclosure Designation
									Features: N=Non-Programming
									Fixed or Dimming: C=0-10V R=Leading Edge & Trailing Edge Dimming F=Fixed
									Max Voltage: Examples: 046=46V
									Max Current: Examples: 039=390mA, 078=780mA
									Max Power: Examples: 018=18W, 036=36W
									Input Voltage: I=120-277V G=347V R=120V
General: C=CertaDrive LED									

Electrical design-in

Surge protection

The CertaDrive indoor LED drivers have built-in surge protection up to a certain limit. Additional protection against excessive high surges can be achieved by adding a surge protection device.

The actual limit can differ per driver and can be found in the driver's datasheet in the download section on <http://www.philips.com/oemna>.

Leakage current

CertaDrive LED drivers are designed to meet leakage current requirements per UL 8750 standards. In a luminaire, leakage current may be higher since the LED load introduces additional parasitic capacitance. As such, precautions should be taken at the luminaire level and also if multiple drivers are used in the luminaire.

Electromagnetic compatibility (EMC)

Philips Advance CertaDrive LED drivers meet EMC requirements per FCC Title 47 Part 15 Class A. Compliance with this standard means these products are suitable for commercial and industrial lighting applications.

Improvement in electro-magnetic interference performance

The following practical precautions need to be taken into account in a lighting system to minimize EMI:

- Minimize the differential mode loop area of the LED wires going from the driver to the light source by keeping the wires close together (bundling). This will minimize the magnetic field and reduce the radiated EMI. Long linear light sources are also part of that loop.
- Minimize the common mode parasitic capacitance of the output wiring + light source to earth by keeping the length of the wires between driver and light source as short as possible. Keep the length of the incoming mains wire inside the luminaire as short as possible.
- Keep mains separated from the output wires (do not bundle).
- Do not route any wiring over and/or along the driver enclosure to avoid any coupling/crosstalk with internal components of the driver.
- Ground the lighting system chassis and other internal metal parts to protective earth, never let large metal parts be electrically insulated from functional or protective earth. Always connect the protective/functional earth/equipotential connector or wire from the driver and use equipotential bonding wires for all large metal parts like driver mounting plate, reflector, heatsink, etc. Keep the protective/functional earth/equipotential wires as short as possible to maximize their effectiveness and use, as much as possible, large metal areas (chassis, mounting plates, brackets) for earthing purposes instead. Establish a reliable electrical connection by using a toothed washer and screw(s) fastened with adequate torque.
- Sometimes radiated EMC compliance cannot be achieved, necessitating the use of a 100 ... 300 Ω axial ferrite bead(s) for either mains or lamp wiring (effective for interference between 30 MHz and 300 MHz), or coupling the wires through ferrite cores within the luminaire may improve the overall EMC performance. However, selection of the type and characteristics of the additional filter depends on what frequency components have to be damped and by how much.

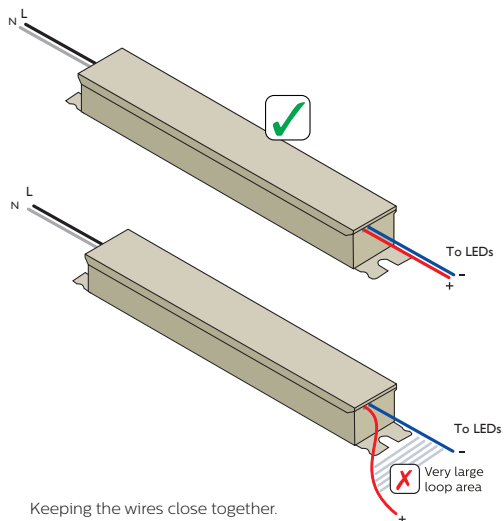

Keeping the wires close together.

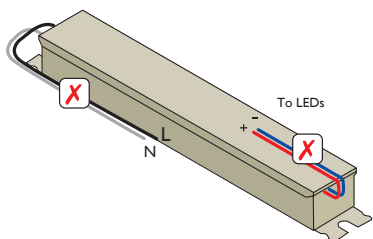

Do not route any wiring over and/or along the driver enclosure.

Adhering to these rules will help in EMC compliance. For further questions, please contact your local Philips sales representative. Alternatively the Philips Lighting OEM design-in team could be consulted for a possible solution.

Electrical isolation

Philips Advance CertaDrive LED drivers meet the UL 8750 safety standard and the UL1310 Class 2 safety standard.

All of the wires in the Philips Advance CertaDrive LED drivers meet the UL1452 safety standards.

Inrush current

Inrush current refers to the brief high-input current that flows into the driver during the initial start-up to charge the capacitors on the input side. Typically, the amplitude is much greater than the operating or steady-state current, as illustrated in Figure 2.

CertaDrive drivers meet the inrush specification values per NEMA 410. The peak and duration values are given in the individual product datasheet.

The best way to reduce inrush is to turn on relays or switches at the zero crossing of the mains. Many controllers do this to reduce the large inrush currents.

What does inrush current do? High inrush currents can cause circuit breakers or fuses to open if not designed to handle this current. It can limit how many drivers can be connected to a circuit breaker (CB) or fuse.

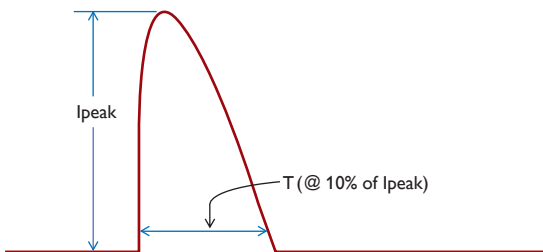

Figure 2. Graphical representation of inrush current.

Note:

Please consult the fuse and circuit breaker manufacturer recommendations when selecting appropriate fuse and/or circuit breakers in conjunction with LED luminaires.

Thermal design-in

The following section covers the critical thermal management points to facilitate design-in. Taking thermal considerations into account will help ensure optimum performance and lifetime of an LED system. The maximum case temperature (T_{c_max}) of the driver should not be exceeded. It is mandatory to keep driver T_{c_max} within specification to meet driver lifetime and failure rate specifications. Please refer to individual product datasheets for specific values (specify CertaDrive number).

Case temperature point

To achieve optimal lifetime and reliability, it is critical that the temperature of the components in the driver remain within its rating. In the driver design, all precautions are taken to ensure that the components within the driver are at the lowest possible temperatures.

Initial thermal analysis is performed via IR scans at room temperature to identify the hottest components of the driver. Subsequently, detailed measurements of the temperatures of the critical components are performed under various input/output conditions at the worst case operating temperatures.

These temperature measurements are related to a T_{case} (T_c) point on the driver as shown in Figure 3. T_c point temperature is a good reference for the temperatures of the critical internal driver components.

The location of the T_c point is identified on the product label. The T_c point on the drivers is on the dot indicated by the arrow (see red circle in Figure 4).

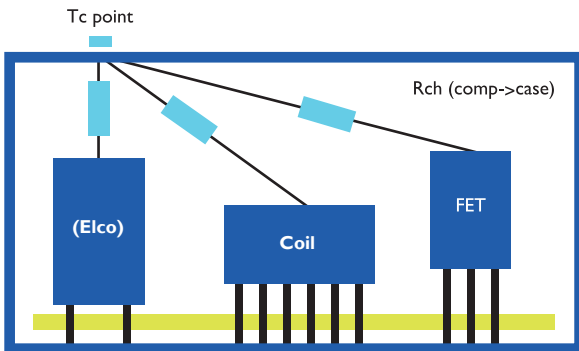

Figure 3. Internal resistance to the driver T_c point.

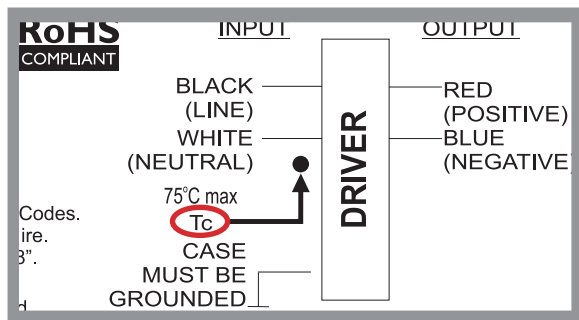

Figure 4. Product label indicating T_c point of an N can driver (detail).

Note:

The specified T_c max of the driver must NEVER be exceeded.
 Care must be taken to ensure thermal stability has been reached before recording T_c measurement.

Mechanical mounting

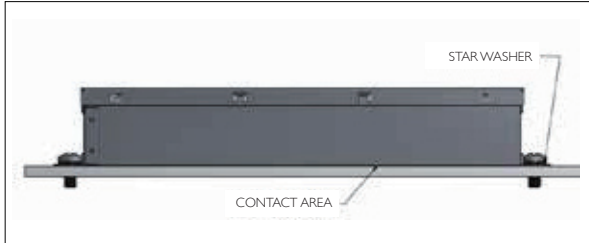

Figure 5. Chassis mounting.

Mounting of the LED driver must satisfy three critical issues:

1) Solid fastening of the driver in order to avoid movement of the driver relative to luminaire

The size of mounting screws/bolts needs to be the maximum allowed by the size of driver mounting holes/slots. The tightening torque has to be per screw/bolt manufacturer recommendations.

2) Electrical grounding of the driver

The driver enclosure is painted. It is recommended to use star washers under the head of the mounting screws – the teeth of the star washer breaks through the paint to ensure electrical connection to the grounded fixture.

3) Maximum interface area between driver enclosure surface and luminaire mounting surface (cooler) for best possible driver T_{case} temperature (lowest)

Figure 5 illustrates recommended mounting of the driver. Thermally conductive gap pads (or other thermally conductive grease, paste, etc.) may be used between driver and luminaire surface to eliminate air gaps and further improve driver thermal performance (lower T_{case} temperature).

Disclaimer

The information in this guide is accurate at the time of writing. This guide is provided “as is” without expressed or implied warranty of any kind. Neither Philips nor its agents assume any liability for inaccuracies in this guide or losses incurred by use or misuse of the information in this guide.

Philips will not be liable for any indirect, special, incidental or consequential damages (including damages for loss of business, loss of profits or the like), whether based on breach of contract, tort (including negligence), product liability or otherwise, even if Philips or its representatives have been advised of the possibility of such damages.



© 2016 Philips Lighting Holding B.V. All rights reserved. Philips reserves the right to make changes in specifications and/or to discontinue any product at any time without notice or obligation and will not be liable for any consequences resulting from the use of this publication.

PAd-1612DG 02/16 <http://www.philips.com/oemna>