

Electrical Information	
Input Voltage	Powered by SR driver low-voltage interface
Current Consumption	13mA
Nominal Power Consumption	200mW
Standby Power	< 1 W on luminaire level, including driver standby power
Occupancy Sensing	
Type	Passive infrared (PIR)
Enable/Disable	Default enabled
Detection	Off/Auto-on; Red LED indicates "on"
Eco On Level	0-100%
Hold Time	0.5 - 60 minutes
Viewing Angle	X=72°, Y = 86° (See detection pattern)
Background Light Level	0 - 100%
Prolong Time	0 minutes - infinity
Grace Fading	0-25 sec
Response Time/Fading to Switch On/Off	0.7Sec
Daylight Sensing	
Enable/Disable	Default enabled
Auto-calibration	Upon power-up
Viewing Angle	40° (half value sensitivity); 2% cut-off point at 75°
Task Tuning	
Full Light Setting	0 - 100%
Environment & Approbation	
Operating Ambient Temperature Range	0°C to 55°C
Operating Humidity	0 - 95% non condensing
Storage Temperature	-25°C to 85°C
Storage Humidity	0-95% non condensing
Max Case Temperature (Tcase)	55°C
Agency Approbations	UL, CSA; Tested and approved for use in plenums; FCC ID: 2AF2N-SNS100; IC: 20659-SNS100
Certification	California Title 20
Limited Warranty	5 years
Digital Interface	Xitanium SR
Other	
Status Indicators	Red, Yellow, Yellow LED on: Vacancy & Sensor is functional; Red LED on: Motion is detected
No. Drivers per Sensor	Four drivers per sensor maximum; Wiring polarity must be maintained
Field Configuration	via NFC for IR. Parameters set via Philips field apps

Operation and Configuration via Mobile App

EasySense operates immediately upon installation and energization without further commissioning. If changes from default settings are desired, EasySense can be configured via an app through NFC embedded within the sensor. The "Philips field app" can be accessed on the Google Play Store. For a complete description of the features and default settings—as well as details on the app and recommended Android phones—refer to www.philips.com/easysense.

FCC and IC

This device complies with part 15 of the FCC rules for the United States and Industry Canada (IC) license-exempt RSS standard(s). Operation is subject to the following two conditions: (1) This device may not cause harmful interference, and (2) this device must accept any interference received, including interference that may cause undesired operation. Any changes or modifications not expressly approved by Philips could void the user's authority to operate this equipment. This product is intended for commercial use only.

Ce dispositif est conforme à la partie 15 des règles de la Federal Communications Commission (FCC) des États-Unis et d'Industrie Canada (IC) exempts de licence RSS norme(s). Son fonctionnement est assujéti aux deux conditions suivantes : (1) Ce dispositif ne doit pas provoquer de brouillage préjudiciable, et (2) il doit accepter tout brouillage reçu, y compris le brouillage pouvant entraîner un mauvais fonctionnement. Tous les changements ou modifications non expressément approuvés par Philips, sont susceptibles d'annuler le droit de l'utilisateur à se servir de cet équipement. Ce produit est exclusivement destiné à un usage commercial.

© 2016 Philips Lighting Holding BV. All rights reserved. Philips reserves the right to make changes in specifications and/or to discontinue any product at any time without notice or obligation and will not be liable for any consequences resulting from the use of this publication. philips.com/easysense



Philips Lighting North America Corporation
10275 W. Higgins Road, Rosemont IL 60018
Tel: 800-322-2086 Fax: 888-423-1882
Customer/Technical Service: 800-372-3331
OEM Support: 866-915-5886

Philips Lighting Canada Ltd.
281 Hillmount Rd, Markham, ON, Canada L6C 2S3
Tel. 800-668-9008

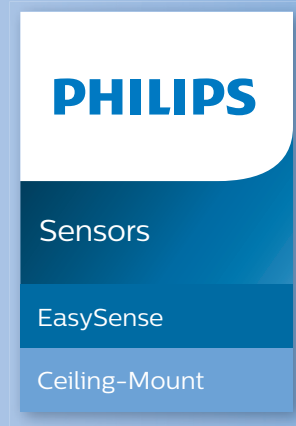

Philips EasySense Quick Installation Guide

Sensor Part Number

Commercial Product Name	Order Code
EasySense Ceiling-Mount Sensor	SNS100CMP (510651) SNS102CMP (514851) SNS200CMP

Compatible LED Drivers

Driver Model Number	Description
XI040C110V054VPT1	Xitanium 40W 0.1-1.1A 27-54V 120-277V SR
XI075C200V054VPT1	Xitanium 75W 0.1-2.0A 27-54V 120-277V SR

Specifications available at www.philips.com/XitaniumSR.

Wiring Diagram

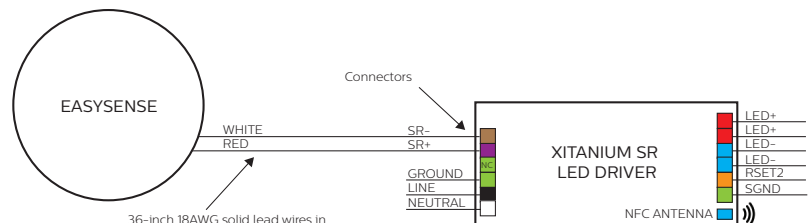

36-inch 18AWG solid lead wires in plenum-rated jacket from sensor stripped to 3/8". Connect white wire to brown (SR-) and red wire to purple (SR+) on driver. Four drivers per sensor maximum. Polarity must be maintained.

Connection	Color
White	Neutral
Black	Line
Green	Ground
Purple	SR+
Brown	SR-

Connection	Color
Red	LED+
Blue	LED-
Orange	RSET2
Green	SGND

Sensor Dimensions (in/mm)

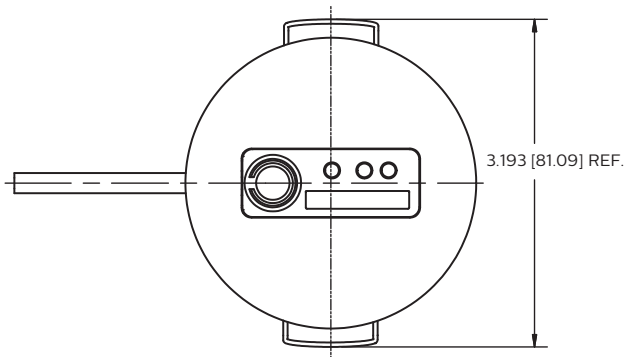
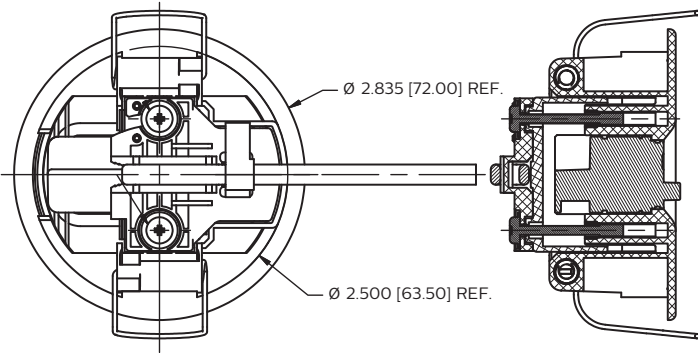
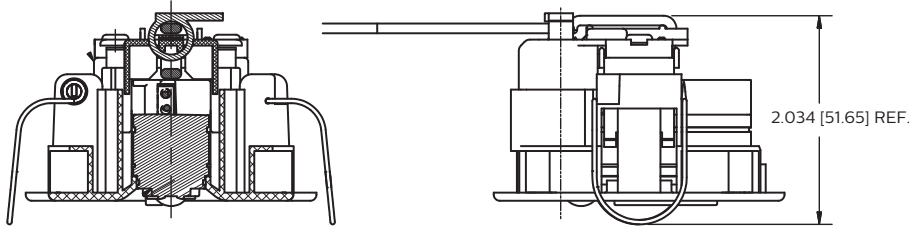

Installation

Note: Remove power from fixtures/drivers before performing any electrical work.



Step 1: Drill 2.5-inch hole in ceiling. It may be more practical to remove the ceiling tile and drill from the backside depending on material.



Step 2: Feed wires from sensor into ceiling hole. Wire length provided is 36-inches. Cable jacket provided is plenum-rated. Add additional wire length if necessary (18AWG solid wire recommended).



Step 3: Compress spring clips on sensor and insert into ceiling hole.



Step 4: Sensor will clamp into place. Turn sensor to appropriate position.

Step 5: Connect the wires from the sensor to the LED Driver in the fixture. Connect the white wire from the sensor to the brown (SR-) terminal on the driver. Connect the red wire from the sensor to the purple (SR+) terminal on the driver. Follow fixture manufacturer's instructions for accessing the driver.

Note: Up to (4) drivers maximum can be connected to (1) EasySense. Polarity must be maintained.

Configuring Sensor Parameters

EasySense operates upon energization with no further commissioning. See sensor datasheet for sensor presets and parameters that can be changed during installation. Refer to "Operation and Configuration via Mobile App" on last page for further details.

