

# PHILIPS

## LED Modules

### Fortimo DLM Flex L2

### 36 G2 NA



**Philips Fortimo LED downlight module (DLM) Flex L2 G2 Dip Switch (DS)** supersedes its predecessors by offering lumen packages up to 13,000lm\* or a high efficacy up to 180lm/W. The new generation also brings the focus on quality of light by introducing CRI 90 range to the portfolio. The all in one DLM Flex L2 G2 provides the ease of switching defined flux levels via a dip switch on board while still allows tuning the models through Advance Xitanium LED Drivers with SimpleSet technology. We bring you the best in class and versatile portfolio which caters to numerous applications.

Commercial Product Name	12NC
FORTIMO LED DLM FLEX DS L2 830 36 G2 NA	929001729113
FORTIMO LED DLM FLEX DS L2 835 36 G2 NA	929001729213
FORTIMO LED DLM FLEX DS L2 840 36 G2 NA	929001729313
FORTIMO LED DLM FLEX DS L2 927 36 G2 NA	929001730113
FORTIMO LED DLM FLEX DS L2 930 36 G2 NA	929001730213
FORTIMO LED DLM FLEX DS L2 935 36 G2 NA	929001730313
Fortimo LED DLM Thermal Accessory G1	929000765413
Fortimo LED DLM Flex Cover NA	929000765313

For drivers' compatibility, please visit our Easy Design-In Tool:  
<https://www.na.easydesignintool.philips.com/select-module/24;jsessionid=B48812A82EB79F03366908351B479626>

\* Achieved with the 84up CRI80

# Fortimo LED DLM L2 36 G2 NA

## Features

- Wide lumen output range: up to 13,000lm\*
- Variation of color temperatures (2700K, 3000K, 3500K, 4000K, and 5000K\*)
- Flexible output/performance when set through the dip switch on board and Philips Advance Xitanium LED drivers with SimpleSet technology
- Lifetime > 50,000hrs<sup>1</sup> (B50L70 at Tc 85°C)
- High color consistency:
  - 2 SDCM for CRI 90
  - 3 SDCM for CRI 80
- Various mechanical interface options:
  - Enabling standard or slim designs
  - Self-cooled option for up to 3,000lm<sup>2</sup>
  - No additional heat sink needed<sup>3</sup>

\* With 84up CRI80

## Benefits

- High energy efficiency (up to 180lm/W at Tc 85°C), also enabling excellent thermal management
- Flexible output/performance when set through the Philips Advance Xitanium LED drivers with SimpleSet technology and the on-board dip switch
- Limited glare
- Integrated thermal protection, enabling universal voltage fixtures and low power consumption (compliant with UL SREC/991)
- Reduced effort with thermal design and testing<sup>3</sup>
- 5-year limited system warranty with Philips Advance Xitanium LED drivers<sup>4</sup>

## Application

- Recessed downlights
  - Offices
  - Hospitality
  - Education
  - Retail
- High-bay
  - Warehouses
  - Industries
- Surface mount luminaries
  - Residential
  - Hospitality
  - Offices

## Optical Characteristics – Table per CCT

Fortimo LED DLM Flex DS L2 830 36 G2 NA					
	DS4	DS3	DS2	DS1	Unit
Nominal Current	485	348	247	215	mA
Luminous Flux	2441	1801	1304	1139	lm
Luminous Flux with DLM Flex Cover	2026	1495	1083	945	lm
Module Efficacy	149	156	162	164	lm/W
Module Efficacy with DLM Cover	124	129	134	136	lm/W
Correlated Color Temperature	3000				K
CRI	>80				-
Color Consistency	<3				SDCM
Radiation Angle	115				degrees
Radiation Angle with DLM Cover	110				degrees

Dip switch settings		
	1	2
DS1	ON	ON
DS2	OFF	ON
DS3	ON	OFF
DS4	OFF	OFF



Note: Specifications stated at Tc nom = 85°C.

Tolerance for flux data is -10% +20%. Tolerance for efficacy data is ±10%.

Measurement precision for flux +/- 5%, for CRI +/- 1.5, for efficacy +/- 6%.

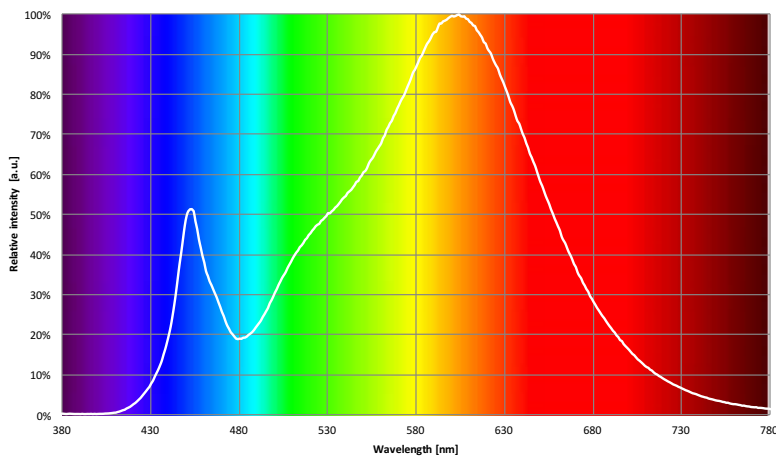

1. Average rated life is based on engineering data testing and probability analysis. The hours are at the B50, L70 point - 50,000 hours life with 70% lumen maintenance at Tc point when used with Philips produced cover and when Philips ESD protection guidelines are followed. Please refer to the design-in-guide for more information.
2. When combined with Fortimo LED thermal accessory G1. Please refer to product design-in guide for design instructions and restrictions.
3. When combined with the Fortimo thermal accessory G1, the need for an external heat sink is eliminated (for up to 3,000lm, according to the product design-in guide rules), resulting in simplified thermal management design and testing. The Fortimo DLM flex design-in guide is available at <http://www.usa.lighting.philips.com/products/oem-components/led-modules-literature.html>.
4. View limited warranty details and restrictions at <http://www.usa.lighting.philips.com/support/support/warranty>. Please note that the warranty is subjected to adherence to Philips ESD guidelines which are embedded in the design-in guide.

# Fortimo LED DLM L2 36 G2 NA

## Optical Characteristics – Table per CCT

Fortimo LED DLM Flex DS L2 835 36 G2 NA					
	DS4	DS3	DS2	DS1	Unit
Nominal Current	485	348	247	215	mA
Luminous Flux	2528	1866	1351	1179	lm
Luminous Flux with DLM Flex Cover	2098	1548	1121	979	lm
Module Efficacy	154	161	167	169	lm/W
Module Efficacy with DLM Cover	128	134	139	140	lm/W
Correlated Color Temperature	3500				K
CRI	>80				-
Color Consistency	<3				SDCM
Radiation Angle	115				degrees
Radiation Angle with DLM Cover	110				degrees

Dip switch settings		
	1	2
DS1	ON	ON
DS2	OFF	ON
DS3	ON	OFF
DS4	OFF	OFF



Note: Specifications stated at Tc nom = 85°C.  
 Tolerance for flux data is -10% +20%. Tolerance for efficacy data is ±10%.  
 Measurement precision for flux +/- 5%, for CRI +/- 1.5, for efficacy +/- 6%.

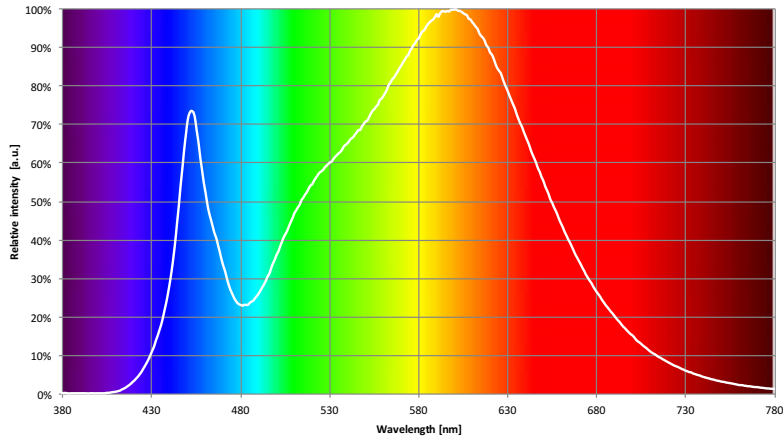

# Fortimo LED DLM L2 36 G2 NA

## Optical Characteristics – Table per CCT

Fortimo LED DLM Flex DS L2 840 36 G2 NA					
	DS4	DS3	DS2	DS1	Unit
Nominal Current	485	348	247	215	mA
Luminous Flux	2615	1930	1397	1220	lm
Luminous Flux with DLM Flex Cover	2170	1602	1160	1012	lm
Module Efficacy	159	167	173	175	lm/W
Module Efficacy with DLM Cover	132	139	144	145	lm/W
Correlated Color Temperature	4000				K
CRI	>80				-
Color Consistency	<3				SDCM
Radiation Angle	115				degrees
Radiation Angle with DLM Cover	110				degrees

Dip switch settings		
	1	2
DS1	ON	ON
DS2	OFF	ON
DS3	ON	OFF
DS4	OFF	OFF



Note: Specifications stated at Tc nom = 85°C.  
 Tolerance for flux data is -10% +20%. Tolerance for efficacy data is ±10%.  
 Measurement precision for flux +/- 5%, for CRI +/- 1.5, for efficacy +/- 6%.

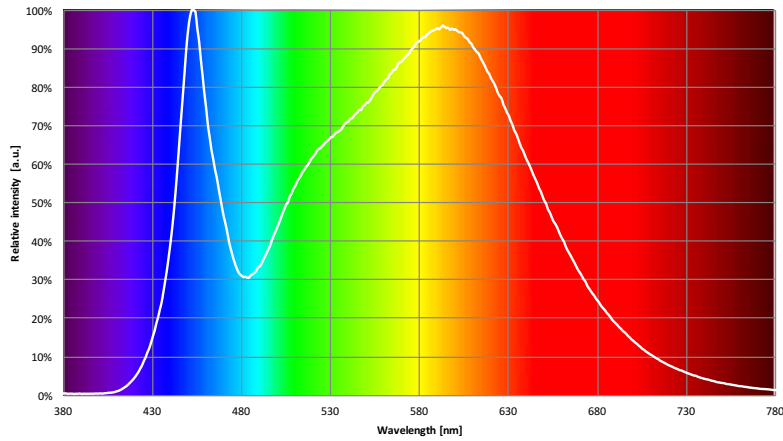

# Fortimo LED DLM L2 36 G2 NA

## Optical Characteristics – Table per CCT

Fortimo LED DLM Flex DS L2 927 36 G2 NA					
	DS4	DS3	DS2	DS1	Unit
Nominal Current	591	419	294	253	mA
Luminous Flux	2326	1731	1259	1097	lm
Luminous Flux with DLM Flex Cover	1931	1437	1045	911	lm
Module Efficacy	114	123	130	133	lm/W
Module Efficacy with DLM Cover	95	102	108	110	lm/W
Correlated Color Temperature	2700				K
CRI	>90				-
Color Consistency	<2				SDCM
Radiation Angle	115				degrees
Radiation Angle with DLM Cover	110				degrees

Dip switch settings		
	1	2
DS1	ON	ON
DS2	OFF	ON
DS3	ON	OFF
DS4	OFF	OFF



Note: Specifications stated at Tc nom = 85°C.  
 Tolerance for flux data is -10% +20%. Tolerance for efficacy data is ±10%.  
 Measurement precision for flux +/- 5%, for CRI +/- 1.5, for efficacy +/- 6%.

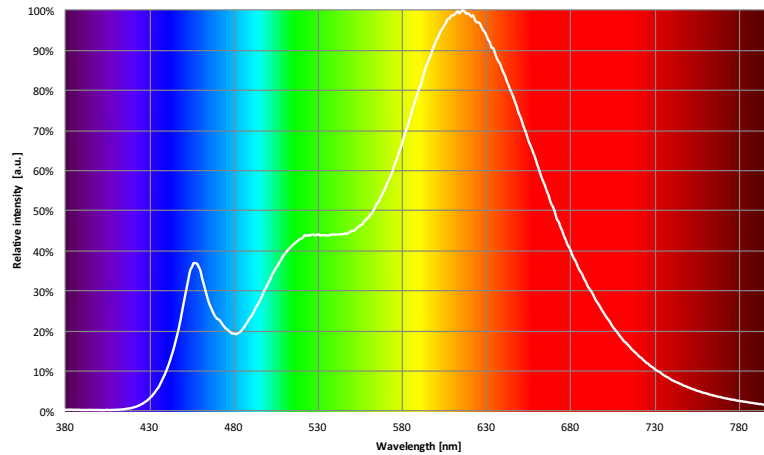

# Fortimo LED DLM L2 36 G2 NA

## Optical Characteristics – Table per CCT

Fortimo LED DLM Flex DS L2 930 36 G2 NA					
	DS4	DS3	DS2	DS1	Unit
Nominal Current	591	419	294	253	mA
Luminous Flux	2422	1803	1311	1142	lm
Luminous Flux with DLM Flex Cover	2010	1496	1088	948	lm
Module Efficacy	119	128	136	139	lm/W
Module Efficacy with DLM Cover	99	106	113	115	lm/W
Correlated Color Temperature	3000				K
CRI	>90				-
Color Consistency	<2				SDCM
Radiation Angle	115				degrees
Radiation Angle with DLM Cover	110				degrees

Dip switch settings		
	1	2
DS1	ON	ON
DS2	OFF	ON
DS3	ON	OFF
DS4	OFF	OFF



Note: Specifications stated at Tc nom = 85°C.  
 Tolerance for flux data is -10% +20%. Tolerance for efficacy data is ±10%.  
 Measurement precision for flux +/- 5%, for CRI +/- 1.5, for efficacy +/- 6%.

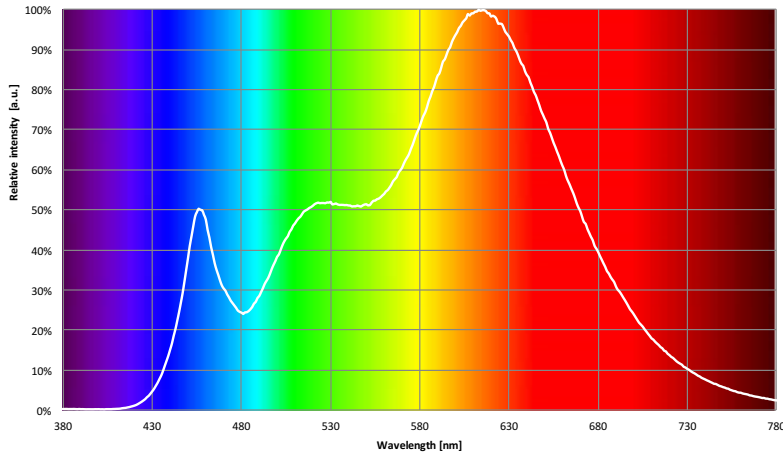

# Fortimo LED DLM L2 36 G2 NA

## Optical Characteristics – Table per CCT

Fortimo LED DLM Flex DS L2 935 36 G2 NA					
	DS4	DS3	DS2	DS1	Unit
Nominal Current	591	419	294	253	mA
Luminous Flux	2491	1854	1348	1175	lm
Luminous Flux with DLM Flex Cover	2068	1539	1119	975	lm
Module Efficacy	123	132	140	143	lm/W
Module Efficacy with DLM Cover	102	110	116	119	lm/W
Correlated Color Temperature	3500				K
CRI	>90				-
Color Consistency	<2				SDCM
Radiation Angle	115				degrees
Radiation Angle with DLM Cover	110				degrees

Dip switch settings		
	1	2
DS1	ON	ON
DS2	OFF	ON
DS3	ON	OFF
DS4	OFF	OFF



Note: Specifications stated at Tc nom = 85°C.

Tolerance for flux data is -10% +20%. Tolerance for efficacy data is ±10%.  
 Measurement precision for flux +/- 5%, for CRI +/- 1.5, for efficacy +/- 6%.

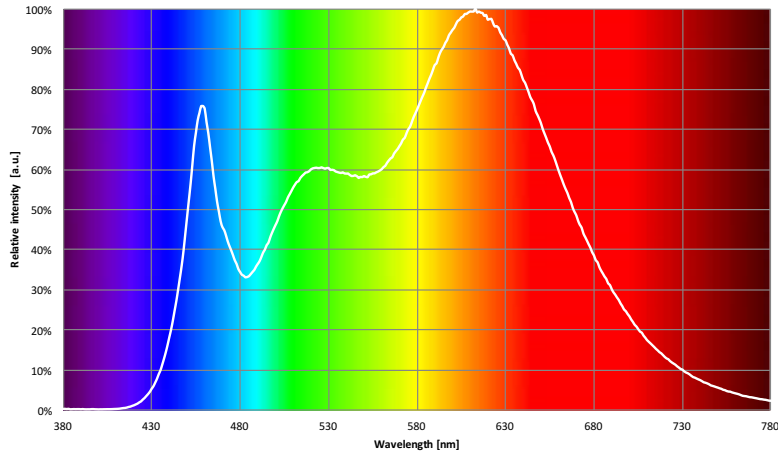

# Fortimo LED DLM L2 36 G2 NA

## Beam Shape

The Philips Fortimo LED DLM generates a Lambertian beam shape, which is a pragmatic starting point for OEMs wishing to design secondary optics.

**Polar Intensity Diagram**  
**DLM Flex L2 36 G2**

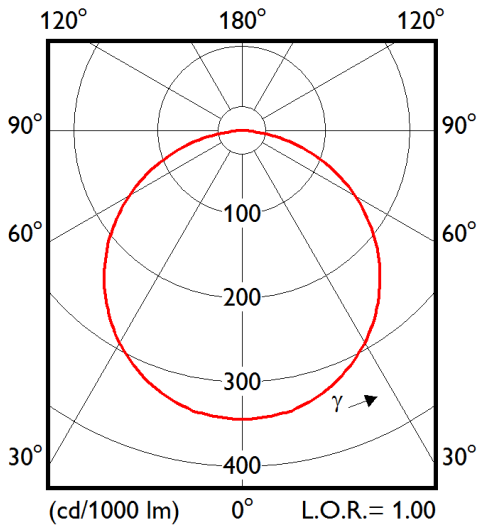

**Polar Intensity Diagram**  
**DLM Flex L2 36 G2 with DLM Flex Cover**

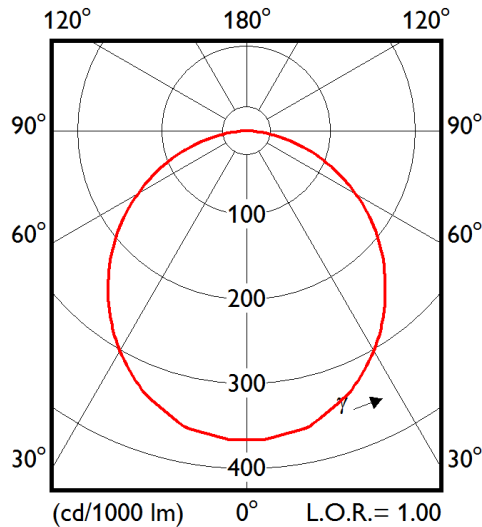

## Electrical Characteristics

**Fortimo LED DLM Flex DS L2 36 G2 CRI 80**

Parameter	Min	Typ	Max	Unit
Current		485		mA
Forward Voltage	32.6	33.9	35.0	V
Power Consumption	15.8	16.4	17.0	W

Note: Specifications stated at Tc nom = 85°C.  
Measurement precision for Vf +/-3%, for Power +/-3.3%

**Fortimo LED DLM Flex DS L2 36 G2 CRI 90**

Parameter	Min	Typ	Max	Unit
Current		591		mA
Forward Voltage	33.9	34.4	35.7	V
Power Consumption	20.0	20.3	21.1	W

## Lifetime

Parameter	Min	Unit
Lumen Maintenance B50L70	50,000	hrs

Note: Lifetime stated at Tc nom = 85°C, refer to lumen maintenance graphs

Parameter	Nominal <sup>5</sup>	Max <sup>6</sup>	Max. Current <sup>7</sup>
Tc [°C] CRI 80	85	95	85
Tc [°C] CRI 90	85	95	75

Refer to the warranty windows

- Nominal value at which performance is specified.
- Maximum value for safety.
- Maximum TC allowed at maximum current within warranty window.



# Fortimo LED DLM L2 36 G2 NA

## Abs Max Ratings

Parameter	Min	Typ	Max	Unit
Current Through the LED module (I-max)			1200	mA
Case Temperature (Tc-max)			95	°C
ESD IEC6100-4-2 (direct)			2 (CRI 80)*	kV
			8 (CRI 90)*	kV
Storage Temperature	-40		100	°C

Storage at humidity <95%, non-condensing

\* Please refer to Philips design-in guide for ESD guidelines.

## Mechanical Characteristics

### DLM Flex L2 36

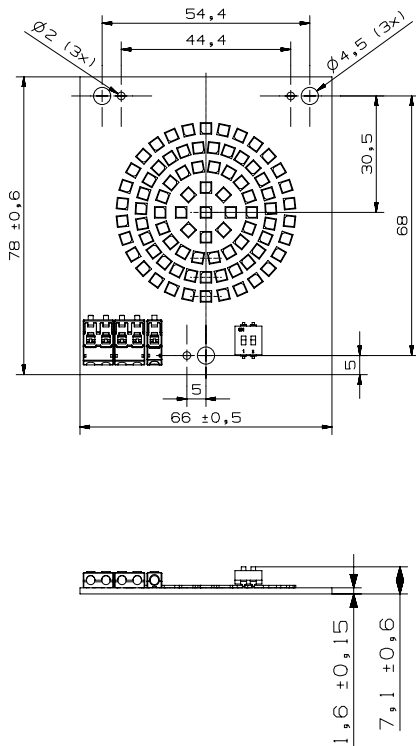

### DLM Flex Cover and DLM Thermal Accessory G1

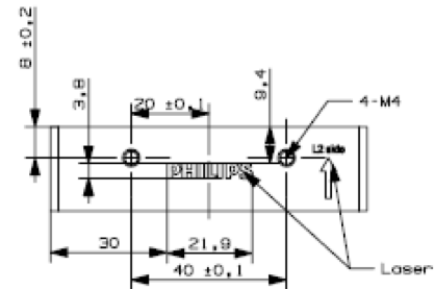
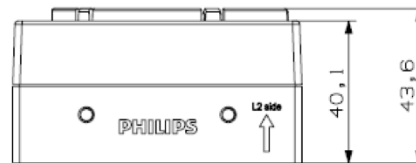
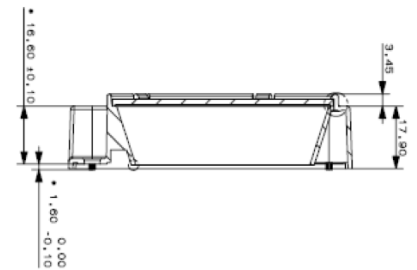
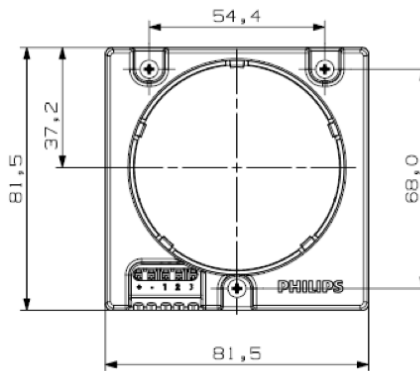

## Application Information

### Compliance and Approval

### Application Information

CSA/ (UL CoA#: E336402)/ UL SREC

Overheating Protection	UL SREC
Luminaire Class	UL Class 2

# Fortimo LED DLM L2 36 G2 NA

## Tuning Information

### Flux and Efficacy versus Current (at Nominal Temperature) DLM Flex L2 36 G2 - CRI 80

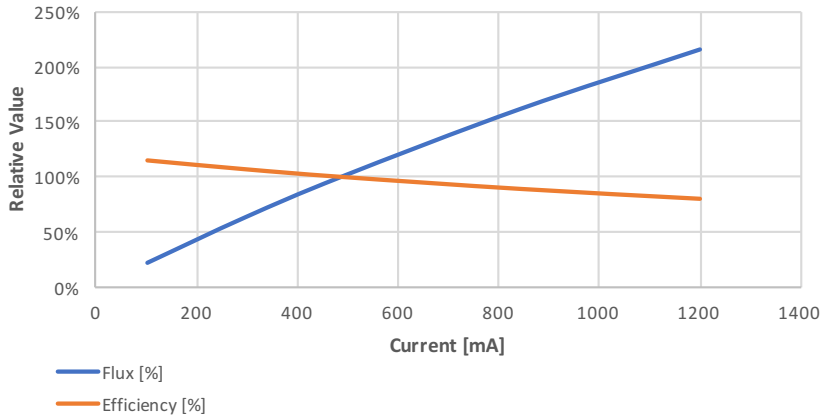

Current [mA]	Flux [%]	Efficiency [%]
100	22%	115%
293	63%	107%
485	100%	100%
843	162%	89%
1200	216%	80%

### Flux and Efficacy versus Temperature at Tc (at Nominal Current) DLM Flex L2 36 G2 - CRI 80

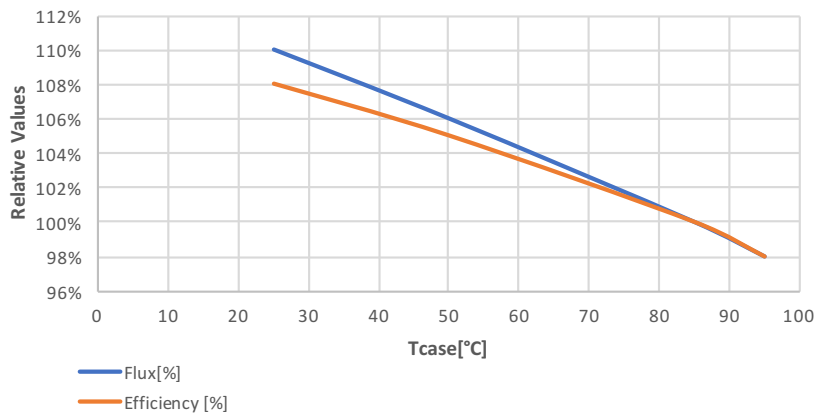

Tcase [°C]	Flux [%]	Efficiency [%]
95	98%	98%
85	100%	100%
50	106%	105%
25	110%	108%

## Warranty Window

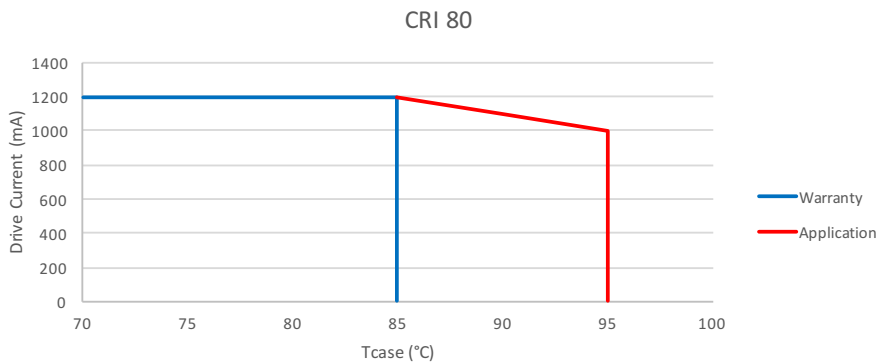

### Warranted Number of Full Thermal Product Cycles within Warranty Window @ 25°C Ambient Temperature CRI 80

Case Temperature Tcase [°C]	Number of Cycles
85	12,500
80	>12,500
75	>12,500
70	>12,500
65	>12,500
55	>12,600

# Fortimo LED DLM L2 36 G2 NA

## Flux and Efficacy versus Current (at Nominal Temperature) DLM Flex L2 36 G2 - CRI 90

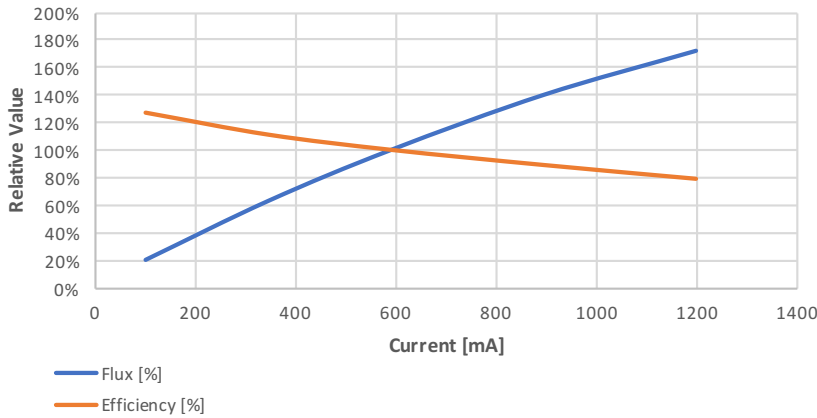

Current [mA]	Flux [%]	Efficiency [%]
100	20%	127%
346	63%	111%
591	100%	100%
896	140%	89%
1200	172%	79%

## Flux and Efficacy versus Temperature at Tc (at Nominal Current) DLM Flex L2 36 G2 - CRI 90

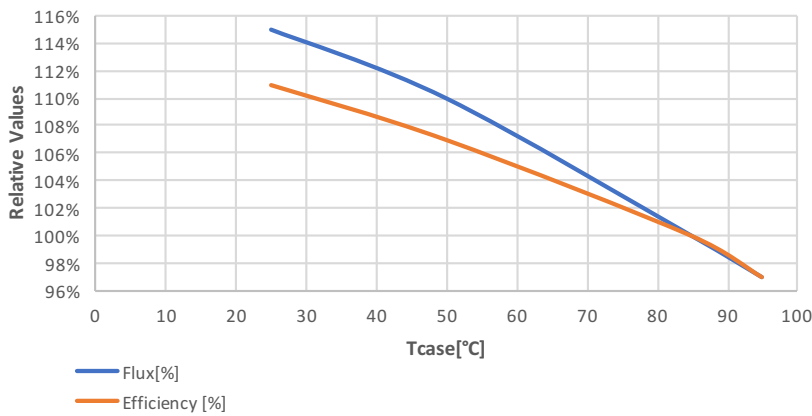

Tcase [°C]	Flux [%]	Efficiency [%]
95	97%	97%
85	100%	100%
50	110%	107%
25	115%	111%

## Warranty Window

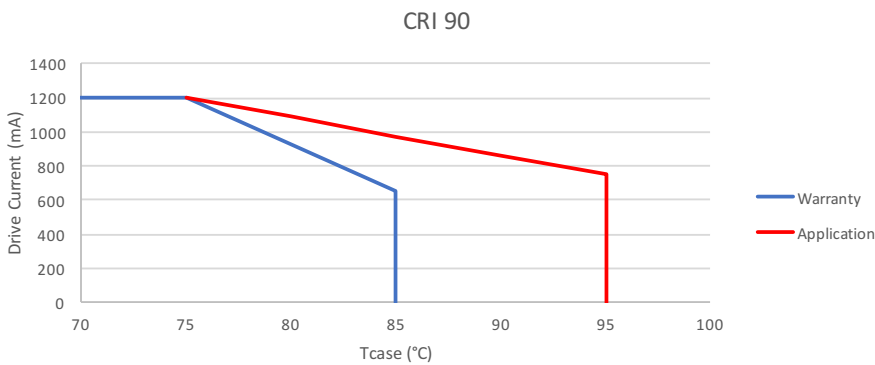

## Warranted Number of Full Thermal Product Cycles within Warranty Window @ 25°C Ambient Temperature CRI 90

Case Temperature Tcase [°C]	Number of Cycles
85	12,300
80	12,500
75	12,500
70	>12,500
65	>12,500
55	>12,500

# Fortimo LED DLM L2 36 G2 NA

## Lumen Maintenance

Fortimo LED DLM Flex L2 36 G2 NA - CRI 80

Lumen Maintenance @ 85C Tcase and Current <Imax

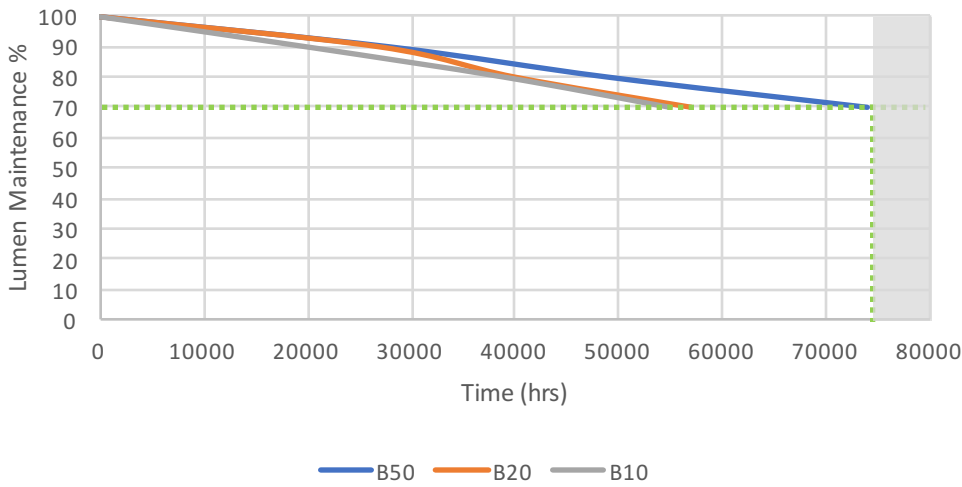

Lumen Maintenance

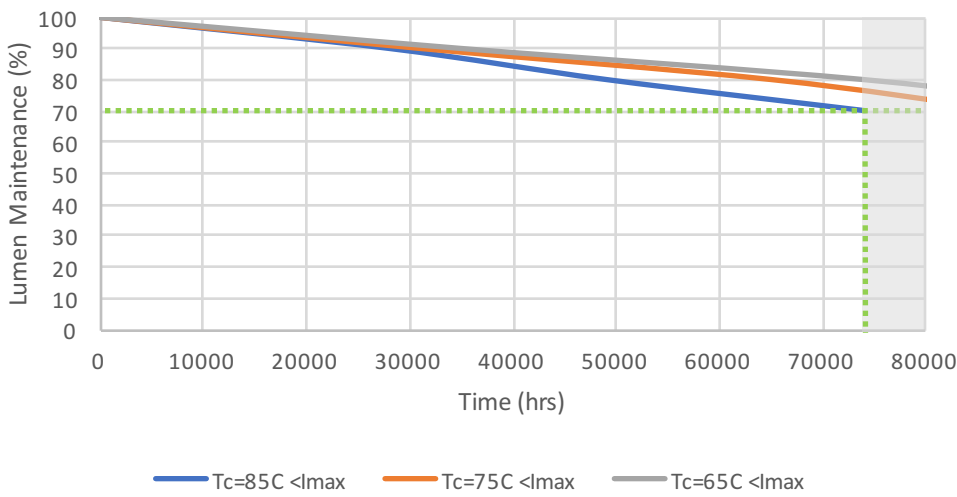

# Fortimo LED DLM L2 36 G2 NA

## Lumen Maintenance

Fortimo LED DLM Flex L2 36 G2 NA - CRI 90

Lumen Maintenance @ 85C Tcase and Current <0.6A

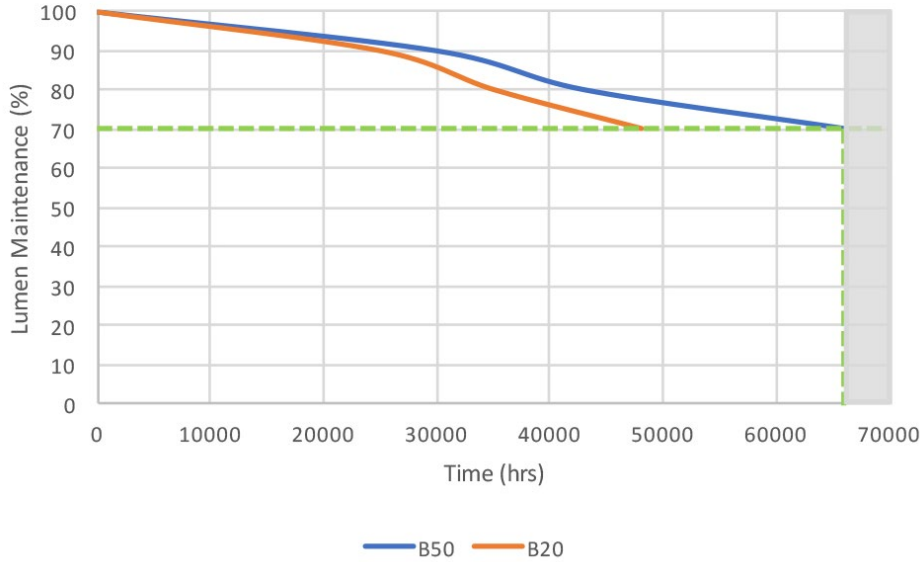

Lumen Maintenance

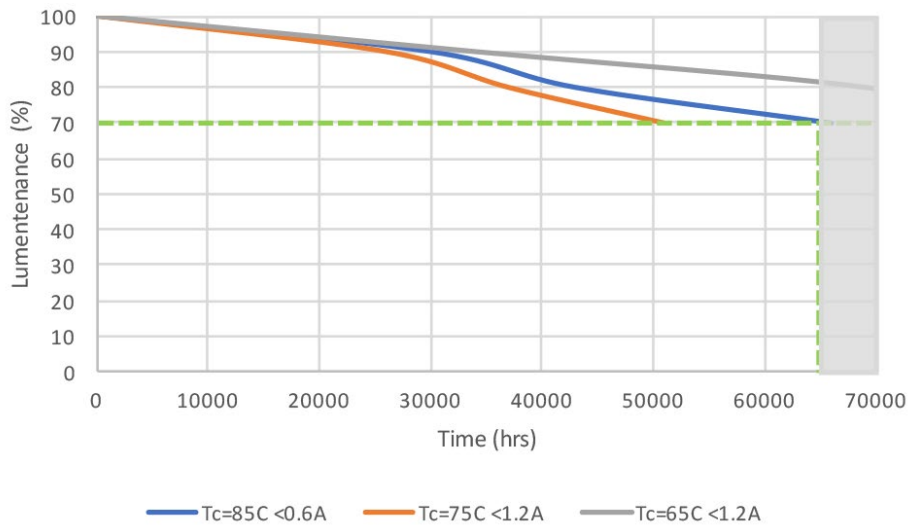

© 2018 Philips Lighting Holding B.V. All rights reserved.  
 Philips reserves the right to make changes in specifications and/or to discontinue any product at any time without notice or obligation and will not be liable for any consequences resulting from the use of this publication.  
[philips.com/ledmodulesna](http://philips.com/ledmodulesna)



Philips Lighting North America Corporation  
 10275 W. Higgins Road, Rosemont IL 60018  
 Tel: 800-322-2086 Fax: 888-423-1882  
 Customer/Technical Service: 800-372-3331  
 OEM Support: 866-915-5886

Philips Lighting Canada Ltd.  
 281 Hillmount Rd, Markham, ON, Canada L6C 2S3  
 Tel. 800-668-9008