

PHILIPS

Wall Mount

Wall pack



Project: _____
 Location: _____
 Cat.No: _____
 Type: _____
 Qty: _____
 Notes: _____

The Philips Wall pack family features energy saving LED technology ideal for wall mounted applications. The Wall pack is available in three sizes to accommodate multiple mounting heights. 30, 50, and 75W options are available to provide 70–250W HID equivalent illumination.

Ordering guide

example: PWP-50-NW-G1--8-BZ

Luminaire	Wattage	Generation	Options	Voltage	Finish
PWP		NW-G1		8	BZ
PWP Traditional Wall Pack	30 30W 50 50W 75 75W	NW-G1 Neutral White, 4000K, 70CRI, Generation 1	-- None PCB Button Photocell	8 120-277 Volts	BZ Bronze

Specifications

Housing

Die-cast aluminum housing and lens frame with heat and impact resistant borosilicate glass lens.

IP Rating

LED light engine is weather proof sealed in a luminaire rated IP65.

Electrical

Driver efficiency (>84% at full load). Available in 120–277V. IP66 compliant driver. RoHS compliant. Surge protector standard. 10KA per ANSI/IEEE C62.41.2.

LED Board and Array

1 or 2 Chip on Board (CoB) LEDs. Color temperature 4000K. Minimum CRI of 70.

Mounting

Mounts to standard 3-½" to 4" round and octagonal or 4 inch square electrical junction boxes. ½ NPT threaded conduit access.

Energy Saving Benefits

System efficacy up to 118lms/W with significant energy savings over Pulse Start Metal Halide luminaires.

Listings

UL/cUL listed to the UL 1598 standard, suitable for Wet Locations. Suitable for use in ambient from -40° to 40°C (-40° to 104°F).

Product is DesignLights Consortium® qualified.

Finish

Each luminaire receives a fade and abrasion resistant, electrostatically applied, thermally cured, triglycidal isocyanurate (TGIC) textured polyester powdercoat finish. Standard color is bronze (BZ).

Limited Warranty

Luminaires are all covered by a 5-year limited warranty. See philips.com/warranties for details.

Lighttogo



Wall pack LED

PWP30/PWP50/PWP75

Dimensions

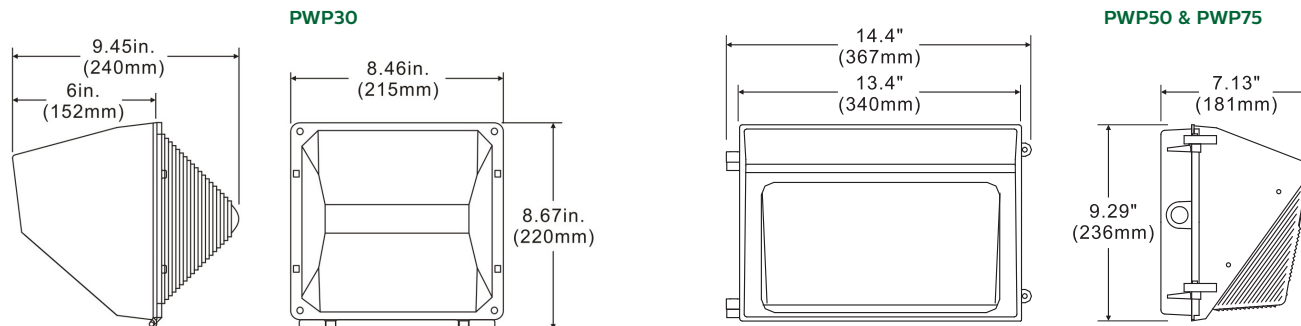

LED Wattage and Lumen Values

Ordering Codes	Total LEDs	System Current (mA)	Color Temp. (K)	Average System Wattage ¹	Lumen Output ^{1,2}	BUG Rating	Efficacy (LPW)
PWP30-NW-G1	1	700	4000	28.8	3355	B1-U3-G3	116
PWP50-NW-G1	1	1200	4000	49	5541	B2-U3-G3	113
PWP75-NW-G1	2	950	4000	76	8999	B2-U0-G5	118

Weight

Product	Weight
PWP30	5.7lbs (2.6kg)
PWP50	8.4lbs (3.8kg)
PWP75	11.5lbs (5.2kg)

1. Wattage and lumen output may vary by due to LED manufacturer forward volt specification and ambient temperature. Wattage shown is average for 120V input. Measured wattage may vary due to variation in input voltage..

2. Lumen values based on photometric tests performed in compliance with IESNA LM-79.

NOTE: Contact outdoorlighting.applications@philips.com for details or additional information.

Predicted Lumen Depreciation Data

Predicted performance derived from LED manufacturer's data and engineering design estimates, based on IESNA LM-80 methodology. Actual experience may vary due to field application conditions. L70 is the predicted time when LED performance depreciates to 70% of initial lumen output.

Calculated per IESNA TM21-11. Published L70 hours limited to 6 times actual LED test hours.

Ordering Codes	Ambient Temperature °C	System Current	L ₇₀ per TM21 ^{2,3}	Lumen Maintenance @ 50,000hrs
PWP30-NW-G1	25 °C	700mA	>102,000	90%
PWP50-NW-G1	25 °C	1200mA	>102,000	90%
PWP75-NW-G1	25 °C	950mA	>102,000	90%

1. Predicted performance derived from LED manufacturer's data and engineering design estimates.

2. based on IESNA LM-80 methodology. Actual experience may vary due to field application conditions.

L70 is the predicted time when LED performance depreciates to 70% of initial lumen output.

3. Calculated per IESNA TM 21-11. Published L70 hours limited to 6 times actual LED test hours.

© 2019 Philips Lighting Holding B.V. All rights reserved.
Philips reserves the right to make changes in specifications and/or to discontinue any product at any time without notice or obligation and will not be liable for any consequences resulting from the use of this publication.
philips.com/Lighttogo



Philips Lighting North America Corporation
200 Franklin Square Drive, Somerset, NJ 08873
Tel. 855-486-2216

Philips Lighting Canada Ltd.
281 Hillmount Rd, Markham, ON, Canada L6C 2S3
Tel. 800-668-9008