

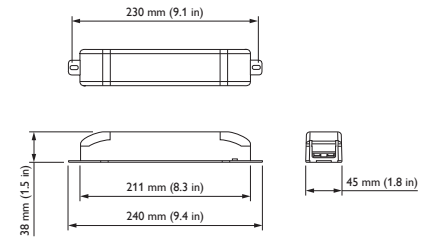

# DMRC210-RJ-DA Relay Controller

## Intelligent sub-networked control of luminaires

The Philips Dynalite EcoSet DMRC210-RJ-DA relay controller is designed to allow intelligent, sub-networked control of luminaires, when used in combination with the EcoSet DUS804C-RJ-DA occupancy sensor.



- Incorporates two relay outputs — Two independently controlled relay outputs designated for switching lighting loads.
- Gear enclosure mounting — Compact design allows the device to be mounted directly within the gear enclosure of many light fittings.
- Fully rated device — Suitable for large in-rush lighting loads.
- Dipswitch configuration — Allows rapid set area configuration and provides out-of-the-box functionality without the need for a PC and software on-site.
- Standalone or networked operation — Though programmed without PC software, the device can be integrated into a fully networked Philips Dynalite system when extra functionality is required.
- Inbuilt diagnostic functionality — Features Device Online/Offline status indication.

For detailed product information, please refer to the product information pages at [www.philips.com/dynalite](http://www.philips.com/dynalite) and follow the links.

## Specifications

Due to continuous improvements and innovations, specifications may change without notice.

Item	Specification	Details
Electrical	Input Voltage	100 - 240 VAC 50 / 60 Hz Single Phase @ 20 A
	DyNet DC Supply	12 V @150 mA (supply for approx 7 user interfaces)
	Outputs	2 x switched @ 10 A (inductive) Maximum device load 180 A
	Switching Device	Relay, Tungsten pilot contact, 16 A inductive, 165 A surge
Control	Control Inputs/Outputs	One DMX512 / RS-485 DyNet serial port
	Preset Scenes	170
	Diagnostic Functions	Device online/offline status
Physical	Supply Terminals	Line, Neutral 1 x 4 mm <sup>2</sup> maximum conductor size
	Output Terminals	Line 1, Line 2, Neutral 1 x 4 mm <sup>2</sup> maximum conductor size
	Network Terminals	Two RJ12 network sockets
	Dimensions (L x W x D)	240 mm x 45 mm x 38 mm (9.4" x 1.8" x 1.5")
	Packed Weight	0.19 kg
	Construction	ABS plastic
	Operating Conditions	Temperature: 0 to 50° C ambient Humidity: 0 to 95% non-condensing
	Storage & Transport	Temperature: -25 to 60° C ambient Humidity: 0 to 90% non-condensing
Certification	Certification	CE, C-Tick
Options & Ordering	Standard Product	DMRC210-RJ-DA (Philips I2NC 913703050109)

## Electrical Diagram

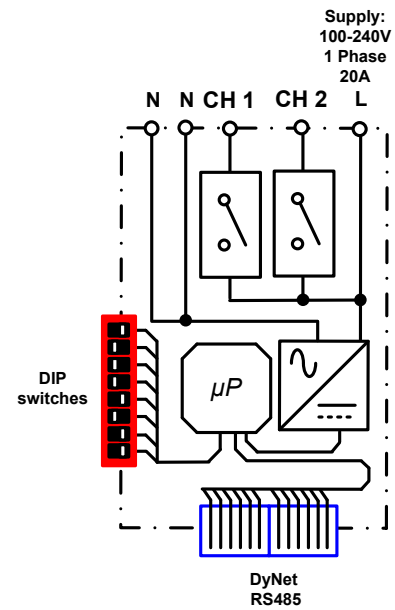

Philips Dyalite  
6 / 691 Gardeners Road  
Mascot, NSW 2020  
Australia  
Tel: +61 2 8338 9899  
Email: dyalite.info@philips.com  
Web: www.philips.com/dyalite

Specifications subject to change without notice. ©WMGD Pty Ltd Trading as Dyalite. Unit 6, 691 Gardeners Road Mascot 2020 Australia. ABN 33 097 246 921. All rights reserved. Dyalite, DyNet and associated logos are the registered trademarks of WMGD Pty Ltd. Not to be reproduced without permission.