



## DR2PE-SA Hotel Room System Actuator

### Simple hotel room automation

The Philips Dynalite hotel system actuator provides a simple individual room energy management solution. Inserting or removing the room access card into the actuator switches between 'occupied' and 'unoccupied' modes to perform a host of functions including opening or closing blinds, switching lighting on or off, selecting pre-set air conditioning settings and controlling power to designated electrical outlets. The DR2PE-SA is suitable for, but not limited to, European, Middle Eastern, African and Asian markets.

- Network capability — Integration with other devices on the Philips Dynalite network provides advanced control functionality from a single control point.
- Extensive designer range — Innovative clip-on cover fastening system provides the ultimate flexibility in décor-matching. Standard finishes include brushed stainless steel and white or black glass. Custom orders available in wood grain, processed stone, laminate or fabric.
- Card holder finish and color choices — Card holders are available in three finishes to complement any hotel room decor. Backlight available in red, green or blue.

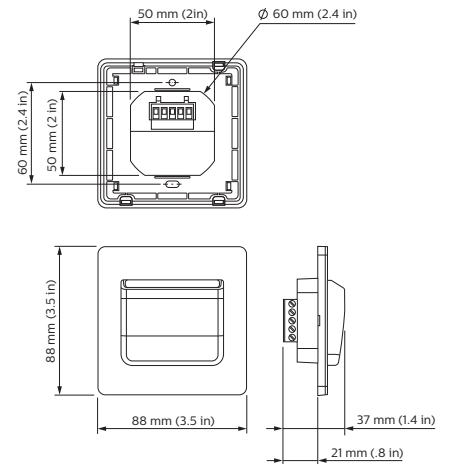

For detailed product information, please refer to the product information pages at [www.philips.com/dynalite](http://www.philips.com/dynalite) and follow the links.

## Specifications

Due to continuous improvements and innovations, specifications may change without notice.

Item	Specification	Details
Electrical	DyNet DC Supply	12V @ 50 mA from the DyNet network
	Control Inputs	One RS-485 DyNet serial port
Physical	Dimensions (H x W x D)	88 mm x 88 mm x 37 mm (3.5" x 3.5" x 1.4")
	Compatible card size (H x W x D)	86 mm x 54 mm x 0.5 - 2.2 mm (3.4" x 2.1" x .01 - .08")
	Packed Weight	0.2 kg
	Operating Conditions	Temperature: -0 to 50° C ambient Humidity: 10 to 95% non-condensing
	Storage & Transport	Temperature: -25 to 60° C ambient Humidity: 0 to 90% non-condensing
Certification	Certification	CE, C-Tick
Options & Ordering		Contact your local Philips representative for ordering information.



## Exploded Diagram

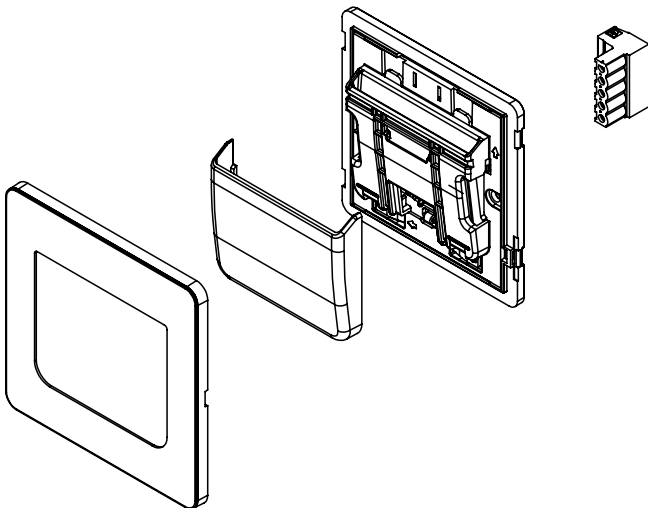

Philips Dynalite  
6 / 691 Gardeners Road  
Mascot, NSW 2020  
Australia  
Tel: +61 2 8338 9899  
Email: [dynalite.info@philips.com](mailto:dynalite.info@philips.com)  
Web: [www.philips.com/dynalite](http://www.philips.com/dynalite)

Specifications subject to change without notice. ©WMGD Pty Ltd Trading as Dynalite. Unit 6, 691 Gardeners Road Mascot 2020 Australia. ABN 33 097 246 921. All rights reserved. Dynalite, DyNet and associated logos are the registered trademarks of WMGD Pty Ltd. Not to be reproduced without permission.