

CoreLine WT120C Waterproof

Installation instructions

Instructions de montage

Instrucciones de montaje

Kokoonpano- ja kiinnitysohjeet

Szerelési utasítások

Montageanleitung

Instrues de montagem

Montaj yönergesi

Návod k montáži

Montage instruktio

Monteringsinstruktioner

Οδηγίες εγκατάστασης



инструкция по монтажу

Istruzioni di montaggio

Monteringsvejledning

Instrukcja montazu

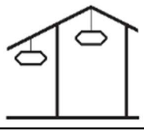
Návod k montáži

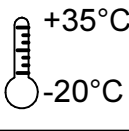
	GLOW WIRE 850°C		CLASS I. 	 +35°C -20°C	220 V 240 V	IP65	IK08	LIFETIME 50k HRS
---	--------------------	---	---	--	----------------	------	------	---------------------

Type	Luminous Flux	CCT	Dimension (mm)						Ptyp (W)	 kg	Nr. of clips
			A	B	C	D	E	F			
WT120C LED18S/840 PSU L600	1800	4000K	82	661	87	38	388	96	19	0,93	6
WT120C LED22S/840 PSU L1200	2200			1223			960		23		
WT120C LED40S/840 PSU L1200	4000			1504			1213		41	1,82	12
WT120C LED34S/840 PSU L1500	3400								29		
WT120C LED60S/840 PSU L1500	6000								57		

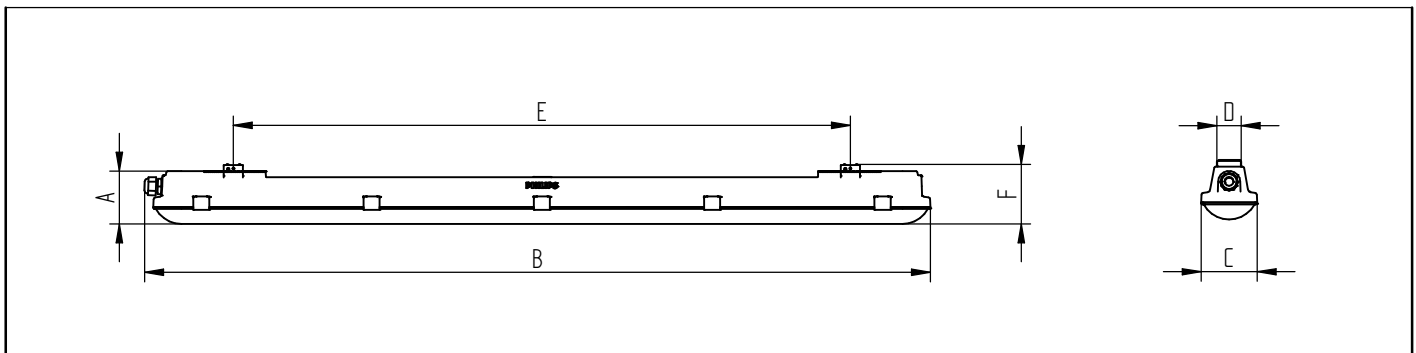

ACCESSORIES INCLUDED IN BOX:

OPTIONAL ANTI-VANDAL MOUNTING

1.

4443 160 02894

Version date 26/09/2013

Data Subject to change without notice

Printed in EU

www.philips.com/lighting

PHILIPS

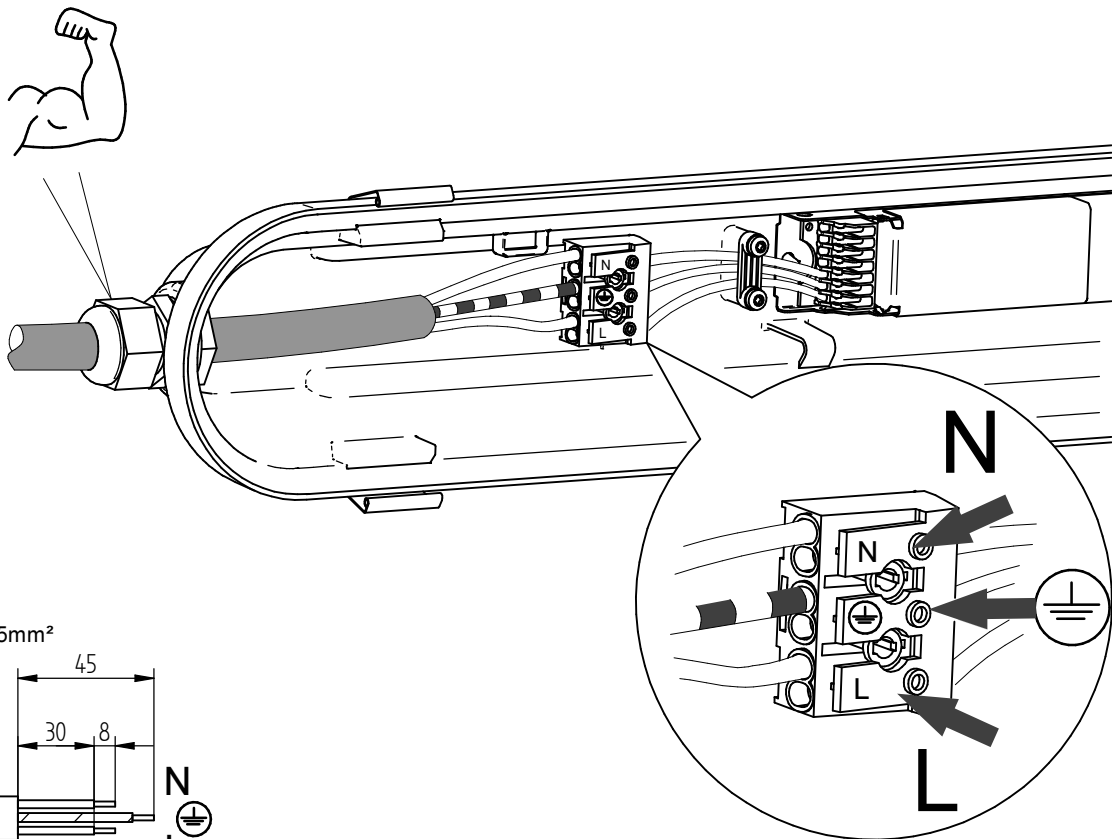

□0,75-2,5mm²

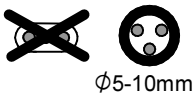
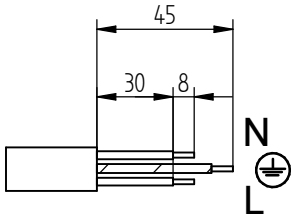

2.

THROUGH WIRING

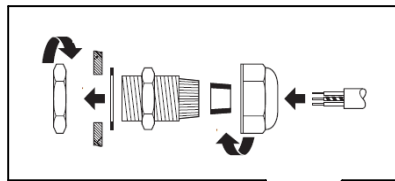
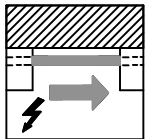

□0,75-2,5mm²

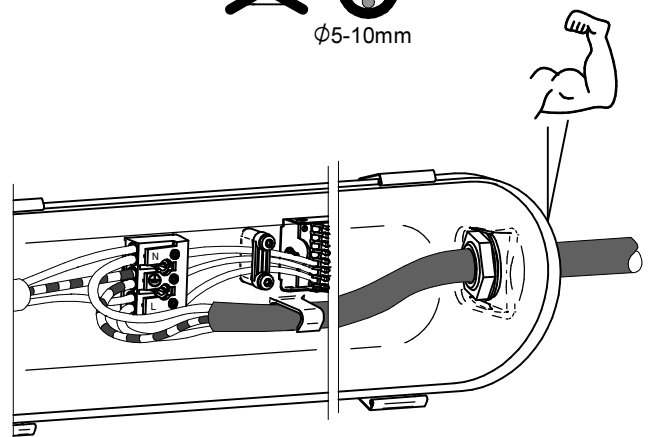
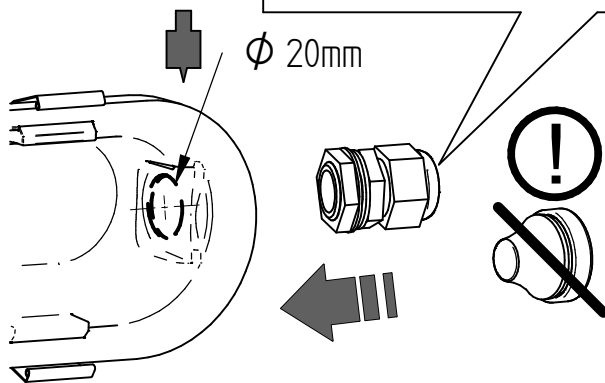
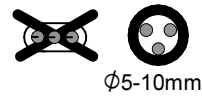
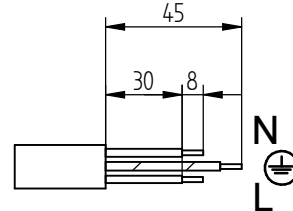

3.

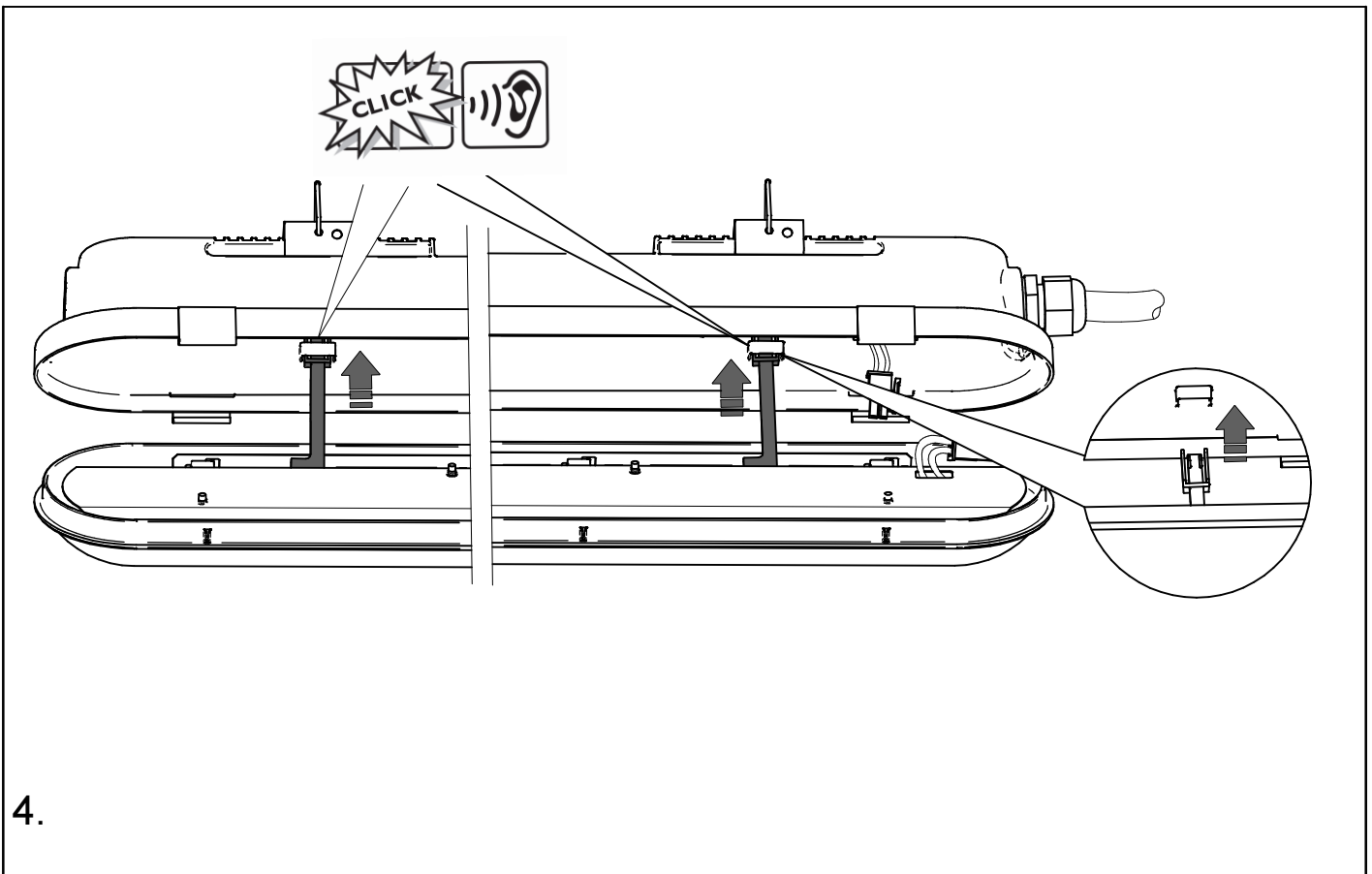

4.

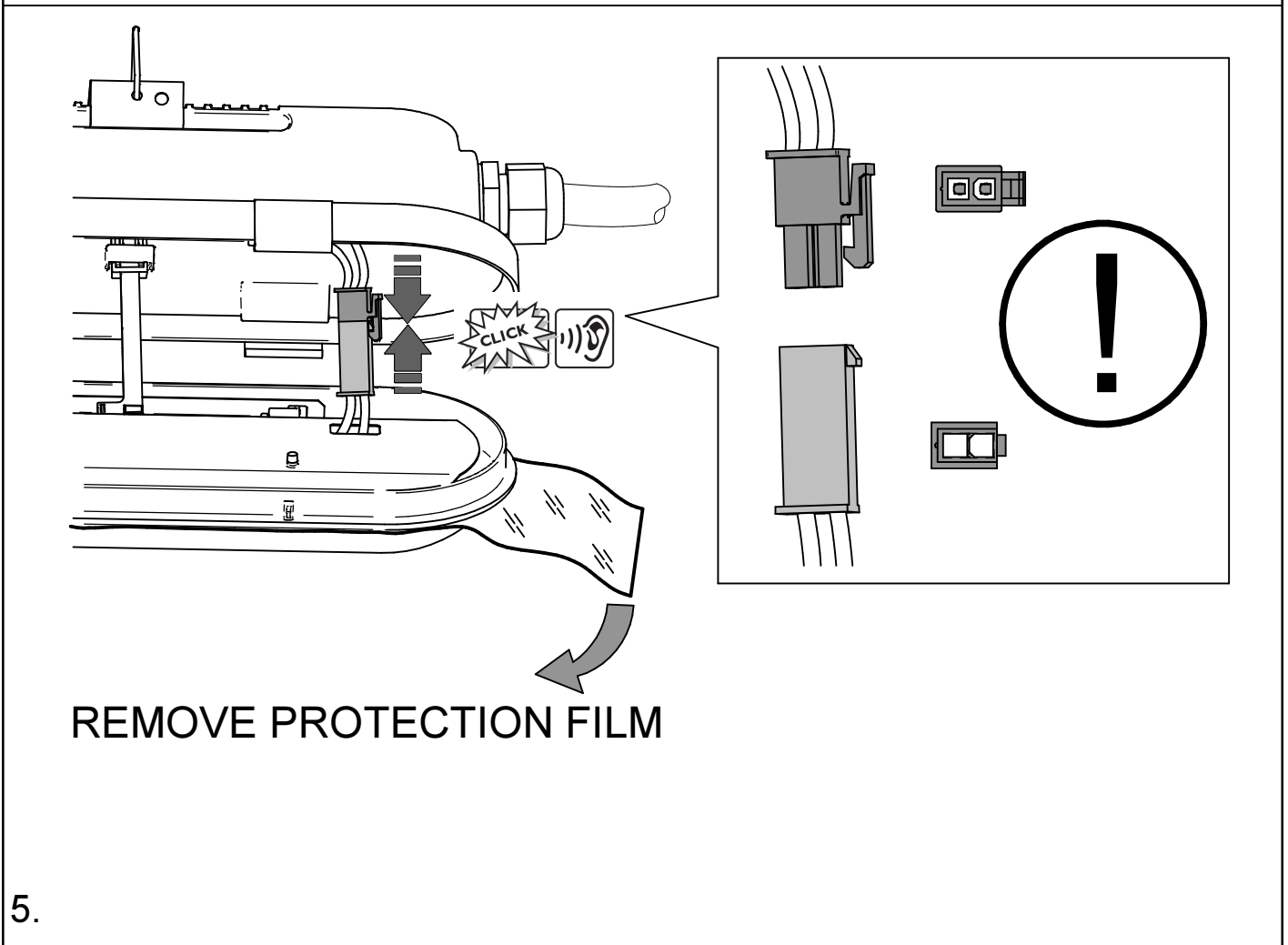

5.

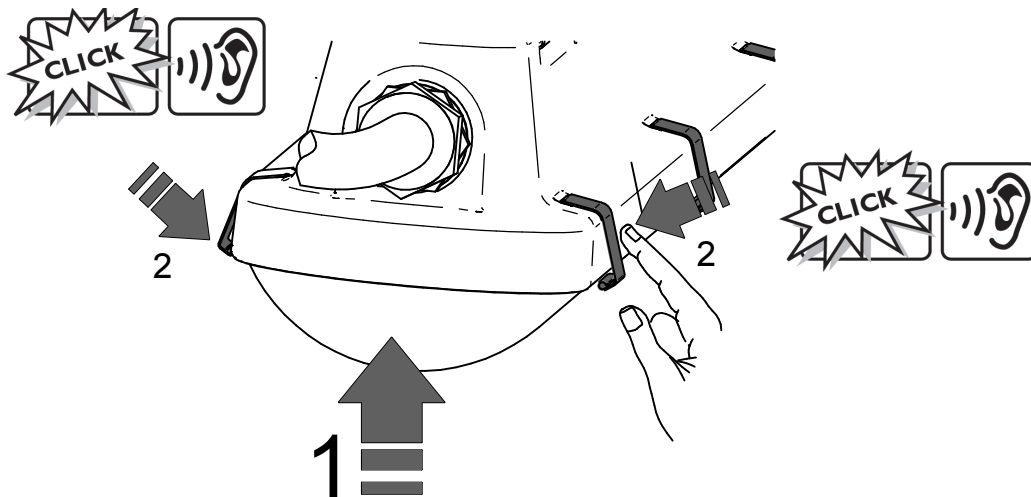

6.

SERVICE (DRIVER REPLACEMENT)

MAXIMAL SCREWDRIVER SIZE:
MAX 8mm

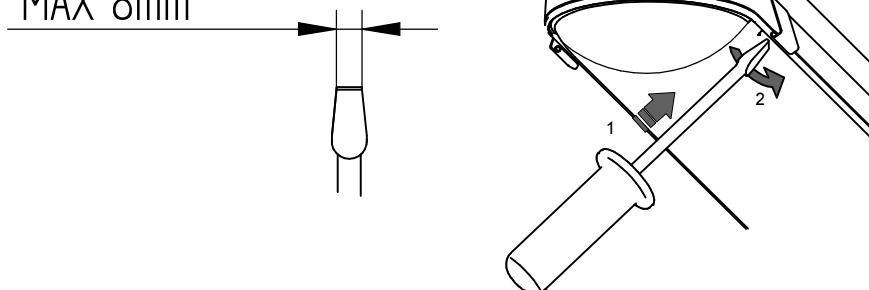

Inrush current peak	22 A (max)
Mains current pulse time half peak	1 ms
Earth leakage current	0.7 mA (max)
Number of drivers on one MCB (16A type-B)*	24 (max)
Number of drivers connected to one 30 mA residual current detector*	24 (max)

*verify per installation

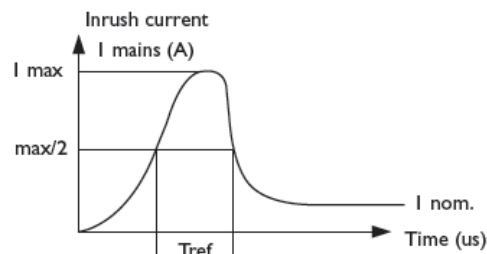

Maintenance instructions

To assure the lighting quality of this unique LED lighting concept there are only a few instructions regarding the maintenance of this LED luminaire:

- * Do not touch electronic components!
Electronic components maybe under high voltage.
- * Do not stare into LED light beam.
- * The luminaire shall be installed by a qualified electrician and wired in accordance with the latest IEE electrical regulations or the national requirements.
- * Above average concentraion of sulfur effects the useful lifetime of the product.
E.g: Light color changes from white to blue. Typically in chicken & pig farms.

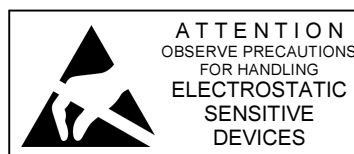

ATTENTION
OBSERVE PRECAUTIONS
FOR HANDLING
ELECTROSTATIC
SENSITIVE
DEVICES

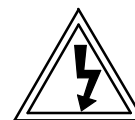

4443 160 02894

Version date 26/09/2013

Data Subject to change without notice

Printed in EU

www.philips.com/lighting

PHILIPS