



OccuSwitch Classic

Self-Contained Passive Infrared
Occupancy Sensor
LRM2240/LRM2245

Philips OccuSwitch Classic self-contained passive infrared ceiling occupancy sensor is the cost effective choice for commercial and institutional applications where installation of a recessed ceiling unit is difficult, inconvenient, or costly.

These sensors use Passive Infrared (PIR) technology to monitor a room for occupancy through a segmented Fresnel lens. This specialized lens divides the field of view into sensor zones. When a person passes into or out of a sensor zone, it detects motion and switches the lights on. The lights will remain on as long as there is an occupant moving through the sensor zones.

The ideal location for the sensor is in a ceiling area that provides a full view of the space with an unobstructed path to the entrance way(s), but out of line from hallway traffic. The sensor should be positioned at least 6 feet from HVAC registers to help prevent false triggering.

Technology

- Passive Infrared technology provides high to low motion sensitivity
- Unit may be mounted directly to a three or four inch octagon box and wires directly to the luminaire
- The sleek spherical shape provides a design that easily blends into most backgrounds
- Sensor and switching relay on a single unit reduces labor for a fast and simple installation
- Adjustable delayed-off time setting between 20 seconds and 15 minutes allows custom adjustment for maximum savings
- An ambient light override option can be set between 2 and 500+ footcandles and full brightness to prevent the sensor from switching lights on when ample natural light is available.
- A standard A/C toggle switch may be used to provide manual-off override so that lights may be switched off
- LED indicator light flashes when sensor detects motion, to verify power placement and function of the sensor at installation

Coverage (Range)

- 360° field of view with approximately 530 sq. ft. of coverage when mounted at 8 ft. This reduces the number of additional sensors typically required in many spaces

Compatibility

- Compatible with Philips Advance Optanium programmed start electronic fluorescent ballasts and Xitanium LED drivers

Applications

- Suitable for storage areas, copy rooms, small spaces without wall switches, small bathrooms, and closets

Job Information	Device Type #: _____
Job Name: _____	
Cat. No.: _____	
Notes:	

PHILIPS

OccuSwitch Classic

Self-Contained Passive IR Occupancy Sensor (LRM2240/LRM2245)

Technical specifications*

Indicator: Red LED lamp—infrared motion

Lens: Segmented Fresnel lens contains 79 segments for optimum sensitivity and detection performance

Timer settings: Manual—20 seconds to 15 minutes

Construction: Housing—rugged, high impact, injection molded plastic

Operating environment: 32°F to 122°F (0°C to 50°C); 20% to 90% non-condensing, relative humidity. For indoor use only

Listings: UL Listed and CSA Certified, complies with applicable California Title 24 Energy Code and FCC Regulations

Line voltage: 120–277VAC

Power consumption: 120V–1.45W 277V–1.89W

Operational frequencies: 60Hz

Wire designation: Line–Black; Neutral–White; Load–Blue

Load rating:

1000VA @ 120V

2700VA @ 277V

Wiring diagram:

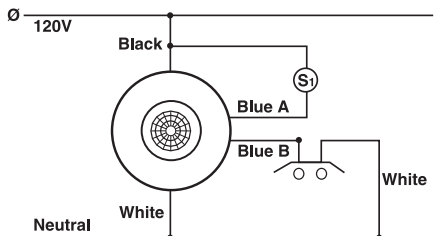

LRM2240/LRM2245 Wiring Diagram with optional switch for override to OFF
* Same wiring for all voltages.

Dimensions:

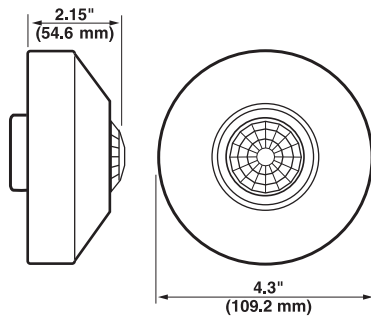

Field of view (in feet):

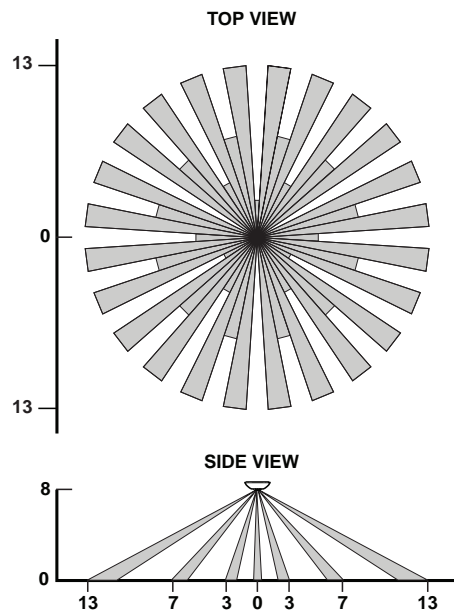

*Subject to change without notice.

Ordering information

Ordering Code	Description
LRM224000	Line Voltage Occupancy Sensor, 120VAC, Ceiling Mount
LRM224500	Line Voltage Occupancy Sensor, 277VAC, Ceiling Mount



© 2011 Philips Lighting Electronics N.A.
A Division of Philips Electronics North America Corporation.
All rights reserved.
Published and printed in USA 10/11

Form No. LRM2240

Philips Lighting Electronics N.A.
10275 West Higgins Road
Rosemont, IL 60018

Contact Customer Care:
Phone: 1-800-372-3331
Via Web: www.philips.com/contactlighting
Website: www.philips.com/lighting