



# The ABC's of DALI

A Guide to Digital Addressable Lighting Interface

**PHILIPS**  
**ADVANCE**

# Table of Contents

1. DALI Sets The New Standard .....	4
2. DALI Features and Benefits	
2.1 Advantages to Lighting Designers .....	5
2.2 Advantages to Facility Managers.....	5
2.3 Advantages to Building Occupants.....	6
3. DALI Technology and Connectivity	
3.1 Ballast.....	7
3.2 Control Units.....	7
3.3 Wiring .....	9
3.4 Voltage Supply .....	10
3.5 System Size .....	10
3.6 Electromagnetic Compatibility .....	10
3.7 Primary Operating Mode.....	10
4. DALI Design Considerations	
4.1 Layout of Ballasts and Controls .....	11
4.2 Planning Checklist.....	11
4.3 DALI and Building Management .....	11
5. DALI Installation	
5.1 Installation Checklist .....	13
5.2 Commissioning.....	13
5.2.1 Assigning Addresses.....	14
5.2.2 Using Individual Addresses .....	14
5.2.3 Using the Group Address .....	14
5.2.4 Creating & Storing Scenes .....	14
5.2.5 Operating Elements/Sensors .....	14
5.2.6 After System Modifications.....	14
6. DALI Applications	
6.1 Simple Light Schemes.....	15
Application A.....	15
Application B .....	15
Application C.....	16
6.2 Complex Lighting Scheme .....	17

# Introduction

DALI, as an acronym, stands for Digital Addressable Lighting Interface. DALI, as a concept, stands for an intelligent lighting management system that provides increased energy savings, easier installation and maintenance, and maximum control and retrofit flexibility – in an entirely open standard.

DALI is not a single product. It is an industry standard protocol that allows DALI-compliant components from different manufacturers (ballasts, control systems, sensors, controllers, switches, etc.) to be mixed and matched together seamlessly into complete systems. With DALI, design and user flexibility is dramatically improved over conventional, proprietary systems.

The purpose of this document is to provide a reference guide for architects, engineers, lighting designers and anyone seeking an understanding of the revolutionary Digital Addressable Lighting Interface system.

# I. DALI Sets The Standard

Lighting control technology has traditionally utilized analog interfaces or proprietary digital control methods. Both have disadvantages. Hard-wired analog dimming systems cannot control individual lights, are fairly complex and costly to implement, and are extremely difficult to modify for later changes in the use of an area. Proprietary digital control methods, while having greater flexibility over analog systems, are still unable to control individual ballasts for ultimate flexibility and are even higher in complexity and implementation cost.

The Digital Addressable Lighting Interface (DALI) defines a new standard for the digital communication between the individual components of a lighting system. DALI provides simplified communication and installation, yet maximum control and flexibility. Wiring is simpler. Installation costs are lower. Each ballast can be individually controlled (addressed) as well as belong to any or all of 16 different groups. Maintenance costs are reduced through central monitoring of ballast and lamp status. Energy costs are lowered through daylight harvesting and standard controls such as occupancy sensors. Moreover, most importantly, the open standard allows interchangeability of DALI ballasts and controls from different manufacturers.

DALI has been designed in a joint effort by leading ballast and control equipment manufacturers with the idea of offering a standard to the lighting market that complies with all requirements and solves complex lighting tasks in a simple and cost-effective manner.

Developed in Europe, the DALI standard is known as Annex E of the European lamp ballast standard IEC 60929, and is progressing towards becoming a global lighting communication standard.

# 2. DALI Features and Benefits

DALI is the ideal, simplified, digital way of communication tailored to the needs of present day lighting technology. Communication and installation have been simplified as much as possible. All intelligent components communicate in a local system in a way that is both simple and free of interference. There are no special wiring requirements — in fact, DALI wiring and power wiring may be installed in one common conduit (subject to local code). The DALI standard provides a full system solution (fixture, lamp, ballast, control and wiring). The advantages of DALI are many, benefiting everyone from the lighting designer to the facility manager and the building occupant.

## 2.1 DALI Advantages to Lighting Designers

The DALI technology provides several key benefits for lighting designers:

**Simple wiring of controls.** Hardwire control groups are eliminated; each individual device has only a power input and digital control input – which are non-polarized, eliminating potential costly installation errors. Controls are wired using the same type of standard wire as is used for power.

**Control of individual lights.** Up to sixteen (16) different light levels, fade times and rates can be programmed and stored in the ballast memory. Each DALI loop can support up to sixty-four (64) individual addresses.

**Flexible group control.** Each DALI loop can support up to sixteen (16) individual groups and each ballast may belong to any or all of the sixteen available groups for unparallelled lighting scene definitions. Simultaneous control of all units is possible at any time through broadcast addressing.

**Software control allows easy configuration and modification.** Dimming specifications can be finalized much later in a project and buildings can be adapted more easily to meet clients' future needs. Lighting designs can be programmed and simulated on a PC for later downloading into the installation. This commissioning method also offers the flexibility of room layout changes without rewiring.

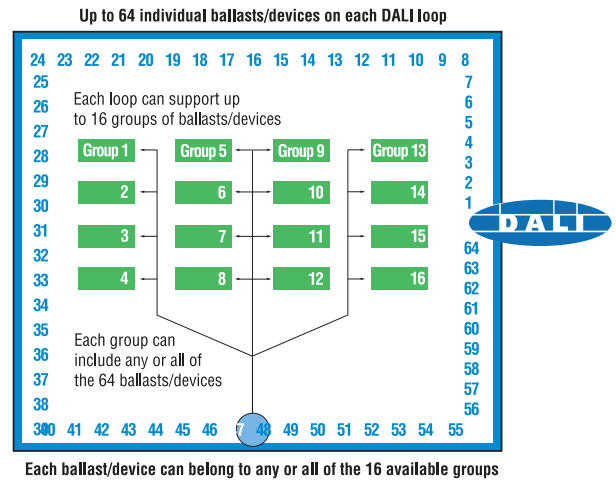

## Simple interface with Building Management Systems (BMS).

DALI can add valuable extra flexibility through its feedback of lighting system information to the BMS, allowing automatic identification of failed lamps and ballasts as well as central monitoring of ballast power and dimming levels. In the simplest situation, the BMS can be used for central overrides such as timed on/off switching or dimming.

## 2.2 DALI Advantages to Facility Managers

The DALI technology provides several key benefits for facility managers:

**Increased space flexibility.** Various instructions can be programmed to accommodate different lighting tasks and situations, such as:

- Meeting spaces that require different lighting scenes for multiple types of uses or events
- Open offices where users can control their own lighting
- Areas such as lobbies or restaurants that reflect time-of day lighting changes

*Simple modification.* Lighting modifications in response to changes in area usage or occupancy are done quickly and easily through a PC, PDA or infrared (IR) remote control. No rewiring is needed.

*Lower maintenance costs.* Diagnostic status of each ballast and lamp is fed to a central monitor for proactive identification of failures or non-responsive fixture. Multiple service trips are eliminated.

*Energy savings.* Energy consumption can be reduced by through “daylight harvesting” (dimming of lamps in response to changing amounts of natural light) and switching strategies such as occupancy sensors and scheduled on/off switching. Peak demand charges can also be avoided with well-planned control setpoints.

### 2.3 DALI Advantages to Building Occupants

The DALI technology provides several key benefits for building occupants:

*Customized lighting preferences.* Any combination of ballasts can be grouped and controlled to accommodate the preferences of individual building occupants.

*More comfortable lighting.* Continuous automatic adjustment of fluorescent lighting in response to changing ambient light levels provides a constant light level on the working surface. Logarithmic dimming technology matches the eye’s sensitivity. Eyestrain is also eliminated due to flicker-free operation of luminaires.

*Individual control.* The DALI system can be configured to allow the occupants control and fine-tuning of their workspace light levels.

*Easy modification.* When needs change, ballasts can simply be reprogrammed instead of disruptive moving and rewiring of fixtures.

# 3. DALI Technology and Connectivity

DALI is an open architecture that allows interchangeability of manufacturers' devices to create a lighting system.

Each DALI loop can control up to 64 devices, each of which is individually addressable (unlike analog interface systems which can only be addressed in common).

Ballasts are connected with standard building wire to a DALI controller, which can be connected to other controllers for centralized control of larger areas. A DALI system can be stand-alone or a sub-system to Building Management Systems (BMS), communicating bi-directionally via a gateway or transmitter.

One DALI system allows the creation of up to 16 groups with individual ballasts being in any or all of the groups. Each group can also have up to 16 settings for various lighting scenes.

A DALI system configuration can be readily modified without any modification of the installation itself.

## 3.1 Ballasts

DALI ballasts utilize standard open communication protocol. Within a DALI system, each ballast has its own address - comparable to a house number assigned to an individual house on the same street. Carrying this analogy further, the DALI interface line (or "loop"), is like the street. This loop includes as many as 64 addresses and each one of the addresses individually communicates with the control device. All units, however, can be contacted at the same time by way of a broadcast.

Group addresses are also possible. Up to 16 groups can be configured to meet the varying lighting requirements of occupants, workspace needs, room functionality, time of day or ambient light levels.

Ballasts can also be individually configured and the parameters are held in the memory of the ballast itself.

These parameters are:

- Light levels
  - Power on
  - Maximum
  - System failure
- Fade time and rate
- Address
- Groups assigned to the ballast
- Light scene values assigned to the ballast (up to 16)

- Ballasts can be part of multiple scenes
- Scenes can be selected by wall box devices

Two-way communication enables bi-directional information flow, enabling the ballasts to provide feedback to the network on information such as:

- Luminaire state (on/off)
- Lamp energy level
- Lamp and ballast condition

The dimming range of DALI ballasts is 0.1% - 100%, the lower limit depending upon the manufacturer. The logarithmic dimming curve is standardized and adapted to the sensitivity of the eye. When electronic ballasts of different manufacturers are used, the overall brightness effect is very similar if the lower limit of the dimming range is equal for all units belonging to the same power class (lamp power).

The central interface power supply powers the loop and may also function as the control unit/communications hub, depending on system design and the chosen components. A maximum current input of 250 mA is allowed on each DALI loop. Each device connected to the interface may consume a maximum of 2 mA. A maximum voltage drop of up to 2 Volts is allowed across the connecting wires from the interface supply to each system component. Due to the low transmission rate, there is no need to use special cables or wires such as twisted or shielded cables. As a rule, a distance of 984 feet (300 meters) should not be exceeded between two communicating units.

## 3.2 Control Units

DALI was developed to make the many benefits of lighting control systems more accessible for a wide range of local room control applications. Before DALI, control systems were either inflexible, hardwired local systems or complex, costly BUS-based Building Management Systems. DALI bridges the gap between these two worlds.

Local room control applications include occupancy sensors, photosensors, local PCs for individual occupant control and wall-mounted controls that enable manual switching to select programmed dimming scenes.

DALI can also be interfaced to various Building Management System (BMS) architectures. A basic application would

be simple central overrides such as timed on/off switching or dimming. DALI can also add extra flexibility to existing applications using 0-10V luminaire interfaces by simply replacing the standard 0-10V ballasts with DALI ballasts. In this retrofit application, feedback of lighting system information is provided to the BMS, such as failed lamps and ballasts and central monitoring of ballast power and dimming levels. (Note, however, that without a DALI control unit, ballasts would not be individually addressable.)

The functionality of a DALI system is defined mainly by the controls. Control units supply the logic coordination between sensors, switch panels and DALI operating equipment. This can be done through a stand-alone unit or by an interface that receives commands from a master system. Intelligent sensors or switch panels with integrated controls are also possible.

Particular attention should be given to the connection between sensors/switches and the control units. There are two wiring variations – the method chosen would depend on the type of light control needed for an area:

#### Method 1

Sensors and switches are joined directly to the control units by separate connections. This method facilitates the use of standard DALI components.

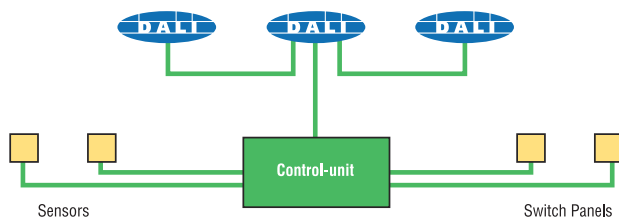

Control units may be wall or ceiling mounted. On the input side is a socket allowing any desired combinations of DALI sensors (movement, daylight, infrared) or switches to be plugged in. Whatever combination is chosen, the controller automatically modifies its internal program and functionality to give optimum performance. The output side is the DALI lighting interface to the ballasts.

#### Method 2

Sensors and switches are connected to the control units by the DALI cables. In this case, no additional wires are needed to link the sensors/switches with the control units.

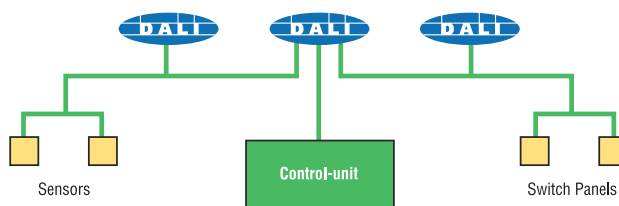

DALI's plug-and-play system capability provides specifiers and installers full compatibility and interoperability of DALI-compliant products from various manufacturers.

#### Technical Characteristics of the Digital Interface :

- Data transfer rate of 1,200 bits per second (bps). Enables an interference-free operation. The physical low level has been defined with the interface voltage at 0V (-4.5V to +4.5V) on the receiver's side. The high-level condition is an interface voltage of 16V (9.5V to 22.5V). A maximum voltage decrease of 2V between the sender and receiver is admissible on the leads of the interface.
- Safety distance of interference voltage. A safe operation is guaranteed by the large-scale interference voltage distance between the sender and the receiver side.
- Maximum system current input of 250mA. Each component connected to the interface may consume a maximum of 2mA. This must be taken into consideration when selecting the power supply.
- Maximum number of 64 units with an individual address.
- Revertive signals of information. Diagnostic feedback from the connected lamps is provided (on/off, brightness, lamp state, etc.)
- Two-wire control lead. Control and supply leads can be wired together, depending on local codes. The maximum lead length between two connected systems must not exceed 984 feet (300 meters).
- Potential-free control input. The control input is separated galvanically from the power voltage. Consequently, all components may be operated with different outer conductors (phases).
- No termination resistors are required.
- Dimming range of 0.1% - 100%.
- Programmable dimming times.
- Interruption of the data transfer. Fixed light adjustments are interpreted automatically (emergency operation).
- Storage of up to 16 lighting scenes.
- Connection to Building Management Systems via converters.

DALI's simple control integration is cost effective for new installations as well as retrofits and future modifications. Compared to traditional hardwired analog interfaces, DALI allows on-site defining and adjusting of ballasts and groups of ballasts without rewiring. Layout changes can now be made just by software alterations via remote control, PC or PDA.



### 3.3 Wiring

DALI system wiring is extremely simple and allows maximum flexibility in system design and installation. Standard cable and wires may be used.

Unlike analog systems, DALI requires no hardwired power circuit control groups. Installation is easier and more economical. The combination of individual ballast addressing with digital switching eliminates vertical switch wiring.

All the luminaires in a room are connected to the nearest unswitched power supply and to a single two-wire control cable from the DALI-compliant lighting controller. Low-voltage wiring can be installed in the same conduit as the power feed wire if local codes allow, or can be run individually as open wire following local codes as per the type of cable needed.

If the layout changes, reconfiguration can be done without changing the luminaire wiring. This allows the use of a single five-wire cable/conduit to install all the luminaires and lighting controls (subject to local codes).

The following illustrations compare the wiring of a traditional analog (0-10V) system with that of DALI:

#### Analog

Function is determined by the wiring of the components as well as sensor and control devices.

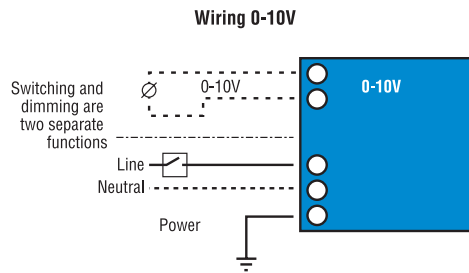

#### DALI

Function is determined by the specific DALI control device that is put into service, and the technical characteristics

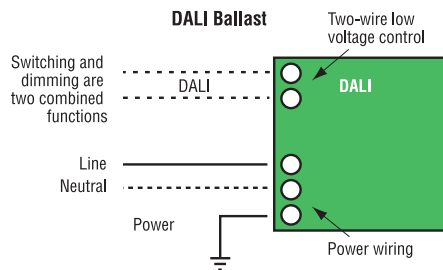

It is not even necessary during planning to consider the allocation of switches, control panels and sensors to the ballasts since this can be done later without any rewiring. The ballast connection configuration can also be considered later, as DALI permits a combination of star and series connections, as illustrated below:

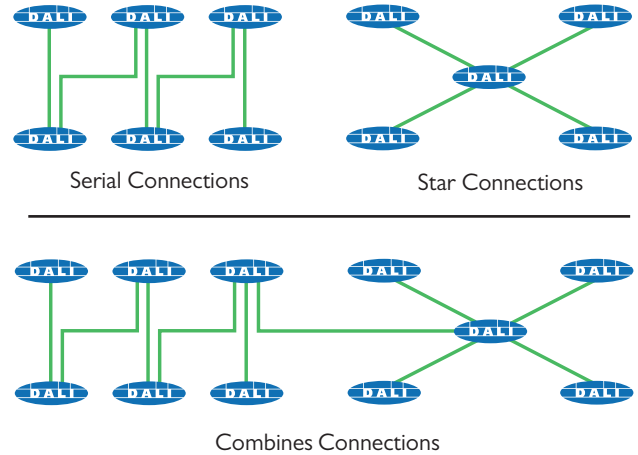

Series wiring may provide easier cable laying, while star configurations can offer an advantage with respect to cable length. As a rule, ring-shaped connections should be avoided. There is no termination resistor at the DALI component cable-ends, eliminating a possible cause of interference in data transfer.

The selection of wires must be adapted to both the length of the connection and the existing terminals. A maximum voltage drop of up to 2V is allowed across the connecting wires from the interface supply to each system component. The supply interface may be installed anywhere in the system or in any device. The maximum distance between two communicating units should be 300 meters (984 feet).

Due to the low transmission rate, there is no need for special cables or wires such as twisted or shielded cables. However, it is necessary to ensure that a clear method of identification is applied.

Control wiring can run in the same cable or conduit as power wiring (check current electrical codes for updated requirements) as illustrated below. The DALI control bus consists of a pair of cables (the same as for the 0-10V interface).



In a DALI system:

- Circuits and lighting schemes are defined and changed by remote control – not by hard wiring.
- Free topology of wiring allows branches and loops, reducing wiring and installation costs.
- Polarity-free connections reduce the chance of wiring errors.
- All sensors are connected via simple plug-and-socket cables.
- DALI control wire and power wiring can be run together, allowing use of a single five-wire cable/conduit (depending on local code) in new installations.
- Power wiring circuits are independent of control circuits, reducing costs by allowing existing power wiring to be used in retrofits.

### 3.4 Voltage Supply (Control)

In general, the digital interface voltage is 16V, ranging from 22.4 - 9.5V. Different units are capable of supplying the interface:

- A separate, central interface supply unit
- A DALI-compliant control unit with integrated interface supply
- A DALI-compliant control device with a supplementary internal interface supply

The maximum system current is limited to 250mA, avoiding an overload on the interface's switching function that has been incorporated into each system component.

The smallest possible system, an electronic ballast with a control unit, requires a current of 2mA max for the electronic ballast on top of the current required for the control unit. There is no limitation to the maximum control unit current.

With the impedances of different interface components being identical in the field, the correct power supply for the system must be selected to correlate to the accumulated currents from the individual components. Good practice is to allow sufficient margins for the supply current. This will guarantee reliable system functionality under different conditions – plus allow flexibility for possible future system expansion.

When a system is operated with several sources of supply, the polarity of the system supply must be considered when connecting the system leads. The maximum total current that is supplied by all sources of the system supply must not exceed 250mA.

### 3.5 System Size

DALI allows up to 64 individual addresses (ballasts) to be connected to one interface line, plus control units and devices. The total current of one interface line cannot exceed 250mA. Exceeding this limit will result in reduced signal integrity. This can cause failures of some components to communicate or respond to commands and the system will become unstable.

System planners must take the power consumption of each component (ballasts, control devices, control units) into consideration – plus incorporate a certain reserve to provide for possible system expansion at a later date.

### 3.6 Electromagnetic Compatibility

With the slope steepness of the transmission signals and the height limits of the voltage levels, there are no high interference levels originating from the signal lead. All equipment used in an installation must meet the stipulations defined in the actual issue of CISPR 15, IEC 61 547, IEC 61 000-3-2 and IEC 61 000-3-3.

### 3.7 Primary Operating Model

There are two primary options of connecting actuators, control units and ballasts with one another:

#### 1. Single Master

In this operating mode, one control unit functions as the actuating master of an interface line. DALI-compliant control panels and sensors are connected to a DALI control unit that also controls the connected DALI ballasts. The ballasts provide information on request by the control unit only. The overall handling has been assigned to this single control unit.

#### 2. Multi-Master

In this operating mode, several DALI-compliant control units (e.g. sensors or panels) work as masters of an interface line. These multiple control units can communicate directly with the DALI ballasts. This operating mode allows easier installation due to less required wiring. However, the controllers must follow some defined "traffic rules" to avoid data collision and to maintain the correct system functions.

# 4. DALI Design Considerations

While a lighting control system utilizing Digital Addressable Lighting Interface components is simpler to design and install than traditional analog or proprietary digital methods, diligent planning is still required to result in a trouble-free system.

The specification will establish the lighting requirements and technical details such as the type of ballasts and controls such as sensors, switch panels and interface modules (see Chapter 3). The general recommendation is to use standard DALI-compliant components only. The functionality of the system is defined mainly by the controls.

## 4.1 Layout of Ballasts and Controls

Organization of the light fixtures and controls is, of course, done during the design phase. A layout drawing such as the example below should indicate the following parameters:

- Light designation
- Floor
- Room
- Position on the plan
- Group reference
- Control address
- Belongs to group

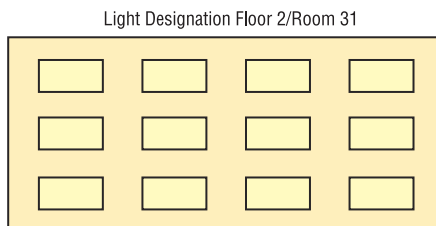

The configuration of the lighting is done during the on-site commissioning (and can be changed later, if so desired). The installers will enter the relevant addresses during the commissioning.

Ref. No.:	Floor	Room:	Position in Plan:	Belongs to Group:	DALI Control address:
L231/01	2	31	01	1	55
L231/02	2	31	02	1	32
L231/03	2	31	03	1;2	34
3622/01	3	22	01		
...	...	...	...	...	...

## 4.2 Planning Checklist

Following are seven simple points to consider during the design phase:

1. Have two wires been included for the DALI interface?
2. Has the maximum cable length been maintained?
3. Have all relevant wiring and electrical regulations been observed?
4. Has the number of DALI components not exceeded recommendations?
5. Have the fields for addresses of DALI components been clearly indicated in the documents?
6. Have all luminaires, sensors, switch panels and control units been considered?
7. Are there any specific requirements for control units?

## 4.3 Dali and Building Management Systems

In its simplest form, a DALI system consists merely of ballasts and a controller. However, the flexibility of DALI makes it readily adaptable for integration with a Building Management System (BMS). The DALI control unit or gateway acts as the master for local communications to and from ballasts. It responds to commands from the BMS control and communicates ballast and lamp status information back to the BMS.

The integration of a DALI lighting control system into a BMS could be done as follows:

### 1. DALI as a Stand-Along System

This is the simplest option. In most cases, it will consist of a simplified control unit not using the full functionality of DALI. It is a real stand-alone lighting control system without connection to the BMS. All functions (even start-up, maintenance, etc.) are done locally. Control elements and sensors are connected to the control unit as usual, in analog or digital form.

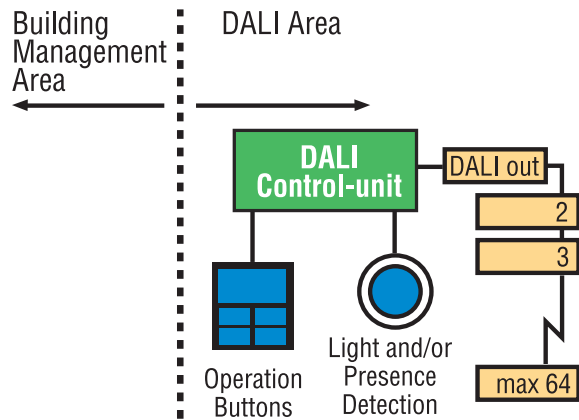

### 2. DALI as a Stand-Along Subsystem

This option is a stand-alone subsystem within the BMS. However, compared to Option 1, it is connected to the building management system. Only the most important information (fault status, central switch functions, etc.) will be exchanged with the BMS. It can be as simple as a “yes” or “no” with regards to faults or failures. DALI-compliant sensors, control elements, programming unit and remote control can be integrated as usual. Initialization can be done via the BMS provided this option is offered by the software. The system is also operational without BMS.

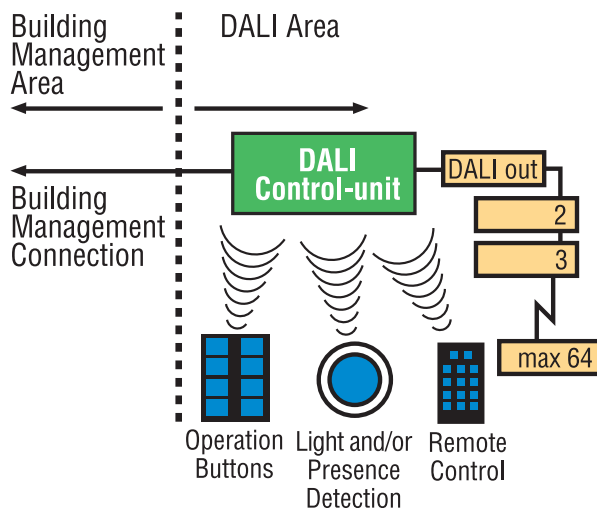

### 3. DALI as Pure Subsystem within the BMS

A translator (gateway) is used for this option. All components installed in a room or building section use the same technique of data transfer as the BMS. The gateway translates from the BMS to DALI and in reverse order to establish communication between BMS and DALI units. Typical applications are BACnet or LonWorks networks that use the appropriate control elements, switches, sensors, etc. The lighting system has not been designed as a standalone solution for this kind of application. Initialization of the lighting control system is part of the start-up process of the complete building management system.

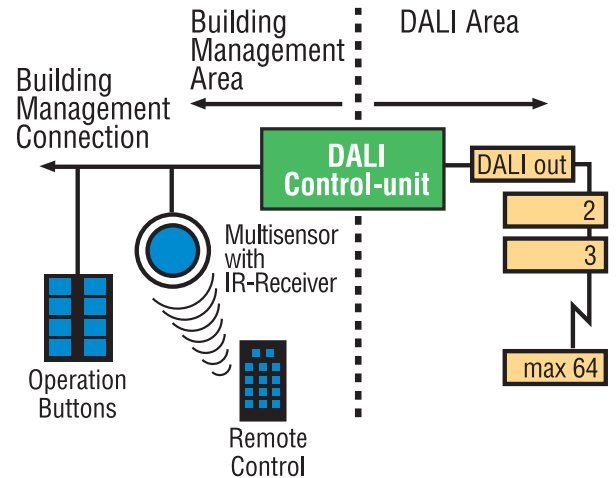

# 5. DALI Installation

**Installation of a lighting control system with a DALI interface must be done in accordance with applicable local building and electrical codes.**

Compared with the 0-10V interface, the DALI control line requires no other electrical installation tool, auxiliary device, or measuring and testing equipment.

There is no requirement for special data wire. However, a clear method of identification is necessary. Both the power supply and the DALI control line can be run through a 5-wire cable/conduit, depending on local code.

The DALI system provides flexibility in layout and connection of the individual DALI components to the DALI control line. However, it is recommended for the sake of clarity that a uniform wiring system be utilized throughout one building.

Power and DALI lines – as well as the associated installation equipment – may be installed in parallel in terminal blocks.

The maximum voltage drop on the DALI line may not exceed 2V. The resulting maximum line length is 300 meters (984 feet), the largest permissible distance between two DALI components, as illustrated below:

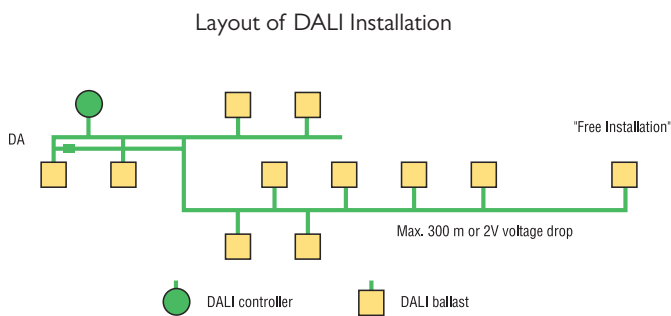

## 5.1 Installation Checklist

Specific details on design and operating characteristics of various DALI system components are provided in Chapter 3. However, following are points to be documented during the final check of a DALI installation:

- Has the installation been done in accordance with applicable codes?

- Line lengths between DALI components:
  - The maximum voltage drop on the DALI line may not exceed 2 V.
  - The maximum line length between the first and the last DALI components may not exceed 300 meters (984 feet).
  - Verify that the planned line length and the actual line length are the same.
- Maximum number of DALI components for each line:
  - The maximum number of components depends on the DALI control device that is used. The DALI standard specifies a voltage of 22.5V and a current of 250mA. The electronic DALI components represent a maximum consumption of 2mA.
  - Verify that the maximum permissible number of 64 operating devices has not been exceeded.
- Function of the DALI operating devices:
  - The DALI operating devices switch to maximum light output when the input power is applied. Check that all operating devices switch to maximum light output when being connected to the input power.
- DALI wiring check:
  - Check that the light(s) can be switched on and off via the control device.
- Testing the functions of the DALI control device:
  - The procedure depends on the manufacturer and must be done in accordance with the manufacturer's specifications.
- Insulation check:
  - The wire used must have the proper voltage insulation in accordance with local codes and meet any other requirements such as a plenum rating in certain ceilings.
- Are there any specific requirements for control units?

## 5.2 Commissioning

Commissioning is the process of assigning addresses and storing the system control information. The commissioning of DALI systems depends primarily on the control device used, so the respective manufacturer's instructions must be followed. The control device software will determine most of the technical characteristics. This section outlines the basic commissioning procedures as defined by the DALI standard.

### 5.2.1 Assigning Addresses

Identification of the connected DALI users (ballasts) is possible as soon as the control device and power supply have been connected. The search for DALI users can be done in two different ways:

The control device registers all operating devices connected to the DALI system using its own basic ID stored by the manufacturer during production (address length is 24 bit). If two addresses are identical, a random function triggered by the control device can be performed within the ballast, creating a new address.

The DALI user will be identified by disconnecting the lamp connection at the operating device. (The operating device must be connected to the power at this time.)

In each case, upon their identification, an individual and/or a group address will be assigned to each known DALI user according to the layout requirements.

Addresses can also be assigned prior to installation, allowing harmonization of all DALI operating devices.

### 5.2.2 Using Individual Addresses

The assignment of an individual address will enable each operating device to be checked and/or error-detected.

### 5.2.3 Using The Group Address

Group addresses can be assigned to any combination of operating devices. This provides combined control of a group. Each ballast can belong to as many as 16 groups. Group addresses can be assigned by the user via control device during the identification phase detailed in the preceding Section 5.2.1.

Grouping can be easily changed later as occupancy or room usage changes.

### 5.2.4 Creating and Storing Lighting Scenes

Once the individual operating device has been identified or groups have been assigned, lighting scenes can be created by setting the individual lighting levels for the individual devices or groups. The individual scenes are programmed via the controller and sent to the individual DALI operating devices (ballasts) where they are actually stored. A maximum of 16 scenes or light levels can be stored for each user. Scenes can be easily changed later as occupancy or room usage changes.

### 5.2.5 Operating Elements and Sensors

The DALI structure enables the use of sensors, push buttons, control consoles, touch panels or even PC operator interfaces. The information can be transmitted via a wire, infrared or radio link. Components must be DALI-compliant and the linking to the DALI system must be done in accordance with the specifications provided by the manufacturer of the control device.

### 5.2.6 Commissioning After System Modification

Whenever new devices are added or existing devices replaced, the new users of the control device need to be identified according to the procedure detailed in Section 5.2.1. This can be done by changing all the addresses or just the selected addresses in accordance with the particular control system. Operating instructions for the control device should be followed.

## 6. Simple Light Schemes

# 6. DALI Applications

## Application A

**Need:** A gymnasium is used for sports activities and special events such as concerts. One side of the gym has large windows. Constant light levels are desired during the day and daylight harvesting is desired for maximum energy conservation. For cleaning, sufficient light levels and energy conservation are the goals.

**DALI Solution:** Four groups were first defined and programmed as follows:

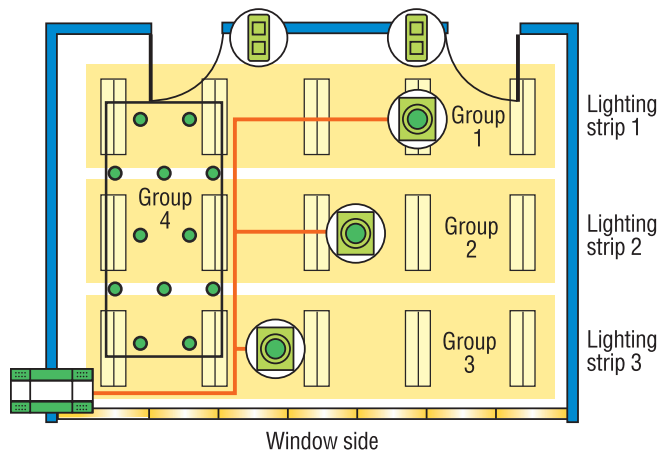

- Groups 1, 2 and 3 are arranged in parallel to the windows in order to create ideal conditions for daylight control.
- Group 4 is wired separately to highlight the stage on special occasions such as concerts.

Five lighting schemes were defined and programmed at installation for this simple scenario (although sixteen schemes are possible):

**Scheme 1:** Constant light control (use of daylight) for sports activities. Groups 1, 2 and 3 are programmed for varying light levels.

**Scheme 2:** Evening sports activities. Groups 1, 2 and 3 are programmed at 100% light levels.

**Scheme 3:** Stage lighting for concerts. Group 4 only is programmed.

**Scheme 4:** Lighting for cleaning. Groups 1, 2 and 3 are programmed at 50% light levels.

**Scheme 5:** Security lighting. One light from each of groups 1, 2 and 3 is programmed at 100%.

## Application B

**Need:** Maximum energy conservation is desired for a small office with one window side. The office will only be used sporadically during the day, sometimes for presentations.

The lighting designer has the options of using a conventional analog control system, a proprietary digital system without addressing, or a DALI system. The goal is maximum control at the lowest installation cost.

**DALI Solution:** The office is divided into two circuits. The window row is regulated to save energy, dimming the lights as daylight levels increase. The entire office is controlled by an occupancy sensor, but when the room is used for presentations, it can be darkened with an infrared remote control wall switch for manual override. A DALI system was chosen because it dramatically simplified installation and lowered costs. (Graphic in lower-right illustrates a retrofit installation.)

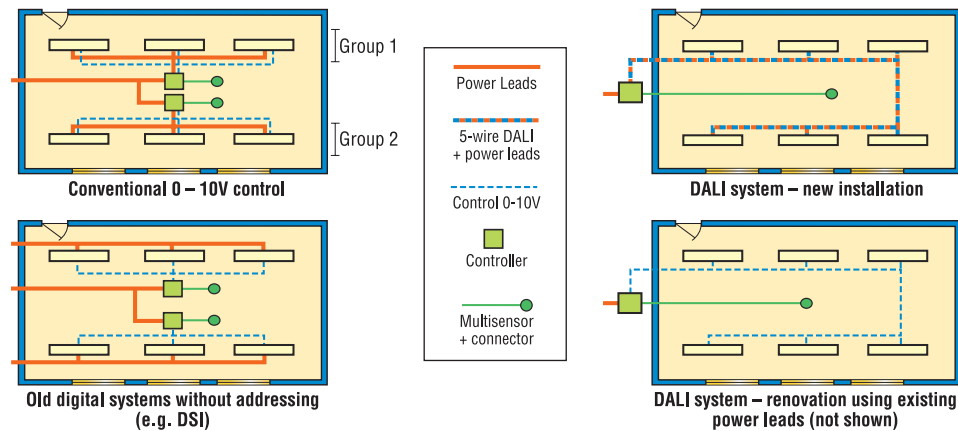

### Application C

**Need:** A room in a workshop for the disabled will have 8 workbenches and a work desk for the instructor. Each row of workbenches is to have a control for switching and dimming the row of lights above that workbench. The room is also to be used as a technical instruction training room.

While individual, on-demand lighting is required, those working in the room must not be troubled with having to control their own lighting. The instructor must have central control of the lighting from the work desk. The use of the room as a training room also requires that the instructor be able to switch and dim the lighting in single and double rows.

**DALI Solution:** DALI provides the high degree of flexibility in group control. The specific DALI addresses seen in the table below clearly match the demands expressed by the user. Fourteen (14) different groups are programmed, but these groups can also be easily adjusted if the lighting profile changes. (Note that this application does not have any light scenes because the room occupancy changes several times a day.)



Lighting	DALI Group No. (max. 16)	Can be operated from
1st row of lights, work bench	1	Work bench 1, desk
2nd row of lights, work bench	2	Work bench 2, desk
3rd row of lights, work bench	3	Work bench 3, desk
4th row of lights, work bench	4	Work bench 4, desk
5th row of lights, work bench	5	Work bench 5, desk
6th row of lights, work bench	6	Work bench 6, desk
7th row of lights, work bench	7	Work bench 7, desk
8th row of lights, work bench	8	Work bench 8, desk
Desk and blackboard lighting	9	Desk
All lights	10	Door Desk
1st + 2nd row of lights	11	Desk
3rd + 4th row of lights	12	Desk
5th + 6th row of lights	13	Desk
7th + 8th row of lights	14	Desk

## 6.2 Complex Light Scheme

Need An office building has five (5) floors, each consisting of a connecting walkway and service access with five separate areas extending from the walkway as adjacent blocks. Each block has the same layout of an open plan working area and an associated meeting room. Three sides of each block extension have glass walls. For aesthetic reasons, the lights must be on at all times. However, a Building Management System (BMS) is set to reduce light levels at night and restore them to working levels the following morning. The BMS must register the action and status of each area at all times.

Each working area must have manual control override by means of a simple push-button panel.

Each meeting room must be remote-controlled by the BMS based on occupancy.

**DALI Solution:** A DALI system was deployed as a subsystem to the BMS, using a gateway/translator for communication from the BMS to the DALI and vice-versa. The BMS has system-wide, on/off and dimming control of the light levels, yet local occupancy lighting requirements are provided.

As illustrated below, a panel for each working area, positioned next to the entry door, allows a number of user-selected scenes. All panel actions are communicated to the BMS via the gateway to maintain system awareness of all manual intervention.

A multi-sensor is used for the meeting room, providing occupancy detection, light measurement and an infrared remote link. A second gateway is used to offer autonomous control of the meeting room. Occupancy information is transmitted to the BMS to facilitate HVAC control in line with occupancy. Also, scheduled light level changes are overridden if

the room is occupied.

The choice of DALI ballasts further simplifies the installation, as the ballasts provide the supply power to the gateways with the control panels and multi-sensors removing the need for separate DALI supply modules. (See illustrations below.)

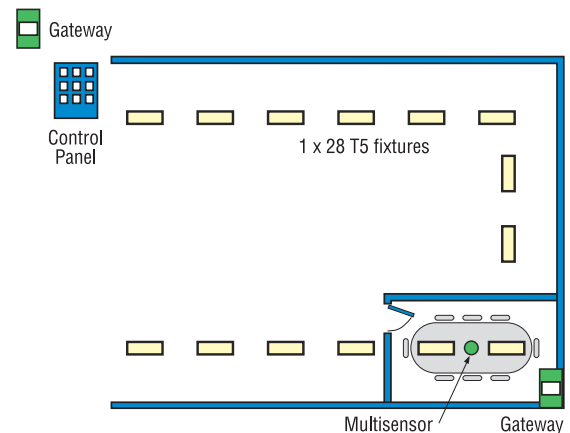

Floor plan showing an open-plan office and associated meeting room.

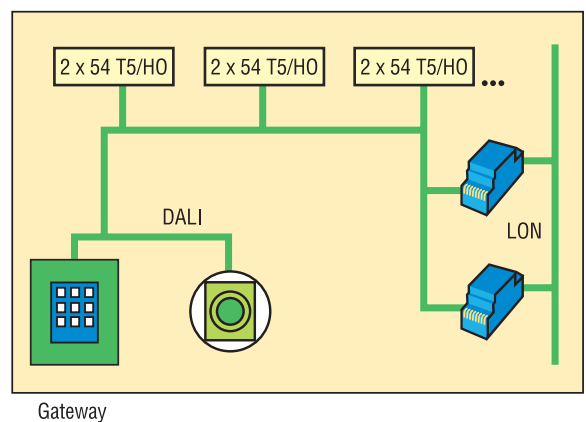



©2009 Philips Lighting Electronics N.A.  
All rights reserved.

Form No. CO-7110-R03 II/09

Philips Lighting Electronics N.A.  
10275 W. Higgins Road  
Rosemont IL 60018  
Tel: 800-322-2086 Fax: 888-423-1882  
Customer Support/Technical Service: 800-372-3331  
OEM Support: 866-915-5886  
[www.philips.com/advance](http://www.philips.com/advance)